

## VULNERABILITY ANALYSIS OF THE HISTORICAL BUILDINGS IN SEISMIC AREA BY A MULTILEVEL APPROACH

L. Binda<sup>\*1</sup>, G. Cardani<sup>1</sup>, A. Saisi<sup>1</sup> and M.R. Valluzzi<sup>2</sup>

<sup>1</sup>Department of Structural Engineering, Politecnico of Milan, Italy

<sup>2</sup>Department of Construction and Transportation Engineering, University of Padova, Italy

### ABSTRACT

An investigation procedure is proposed by the authors to study the vulnerability of the diffuse historic building patrimony in seismic area previously considered as minor, but meaningful testimonies of cultural heritage. The research suggests a "minimal" investigation program, which can support the designers in their projects. The knowledge of existing buildings is approached by considering different analysis levels: history, materials, structural morphology of the wall section, observed damage mechanisms, effectiveness of retrofitting techniques. The methodology, calibrated on four historic centres situated in Umbria (Italy), allowed to define an abacus of the typical collapse mechanisms. This procedure is useful to define the seismic vulnerability also for other similar centres and to critically evaluate the past and future repair techniques.

**Keywords:** stone masonry, historic centres, seismic vulnerability, investigation

### 1. INTRODUCTION

Within a research supported by the Civil Protection Department of the Italian Minister Council aimed to the vulnerability analysis of the historic centres, a investigation procedure has been calibrated. The object of the above mentioned research was not the single building, but the whole historic centre (even if small).

The research (which involved three Research Units: Politecnico of Milan, University of Padua and the Italian Ministry of Cultural Properties) had the strategic aim to: (i) collect information on the effectiveness of the repair techniques, (ii) define a methodology for the analysis of the vulnerability of a building patrimony previously considered as minor, but with meaningful testimonies of cultural heritage, (iii) calibrate and define a "minimal" investigation program, eventually carried out by the municipality or by the province or region. This is carried out in order to support the designers in choosing the right analytical model for the safety definition and the appropriate intervention techniques for their projects.

The unpredicted effects of the 1997 earthquake, which hit the Umbria and Marche

---

\* Email-address of the corresponding author: binda@stru.polimi.it

regions, motivated the study. The damages showed as most retrofitting carried out after the previous 1979 earthquake, mainly performed with upgrading interventions (substitutions of timber floors and roofs with r.c., jacketing, etc.), caused unforeseen and serious out-of-plane effects (large collapses, local expulsions) (Figure 1), due to the “hybrid” behaviour activated from the new and the old structures [1], [2]. That effect was not clearly predictable by the existing assessment methods also suggested by the Italian as well as other seismic codes. The proposed analytical procedures were in fact based on hypotheses often not easy to be satisfied in old historic stone masonry buildings, as the effective strong connection among the structural components and the presence of stiff floors, both characterising the favourable “box” behaviour of buildings under seismic actions. It was also clear that the main cause of inappropriate choice for the intervention techniques was due to the lack of knowledge on the existing materials and on the structural behaviour due to the peculiar type of construction techniques used in the past centuries for the historic buildings.



Figure 1. Example of a) Out-of-plane collapse of a wall with r.c. tie beams, b) roof hammering the masonry walls

The research was focused on four meaningful pilot sites located in the Perugia province (Montesanto di Sellano, Roccanolfi di Preci, Campi Alto di Norcia and Castelluccio di Norcia in Figure 2), repaired after the 1979. The following 1997 earthquake seriously damaged two of them (Montesanto, Roccanolfi).

The selection of the centres was very accurate in order to limit the sample population to the most significant buildings. Information from each building of the four historic centres are being collected in a data-base containing history, overall geometrical (plan, views etc.) and masonry (material properties, section morphology, flat jack and sonic tests) data, representation of the structural system, possible retrofitting, detailed description of the damage, and mechanical interpretation of the damage or collapse processes. Historic minor buildings were often built with poor materials but with effective techniques, refined in the centuries by specific rules [3]. The proposed approach leads to the evaluation of existing buildings by recognising the rules and structural details.



Figure 2. The four pilot sites: Montesanto di Sellano, Campi Alto di Norcia, Roccanolfi di Preci, Castelluccio di Norcia

Such information deals with: i) the technological and constructive characteristics of the surveyed buildings; ii) the material and structure properties (with particular reference to the constructive techniques and to materials used for load-bearing masonry); iii) the materials and the techniques used for restoration before the earthquake; iv) the collapse mechanisms of the buildings and structures due to the earthquake, considering also the ones already retrofitted.

At the end also an analysis on the behaviour of structural components taking into account the previous information could be carried out with the help of automatic procedures in Visual Basic ambient developed at the University of Padova, named VULNUS [4], [5] and CSISMA.

In collaboration with the Civil Protection Dept., a data-base is realised and will be available on internet, built on the basis of the filled forms building by building and with many different research keys. This data-base has the possibility of being linked to other products such as the database of the masonry sections, of the tests results on site and in laboratory, of the abacus of collapse mechanisms and description of techniques for repair.

## 2. BUILDING AND MASONRY TYPOLOGY: GEOMETRICAL SURVEY AND HISTORICAL INVESTIGATION

A preliminary in-situ survey is useful in order to provide details on the geometry of the structure and in order to identify the points where more accurate observations have to be concentrated. Following this survey a more refined investigation has to be carried out, identifying irregularities (vertical deviations, rotations, etc.). In the meantime the historical evolution of the structure has to be known in order to explain the signs of damage detected on the building. The detection of the building typology is the following step to be carried out

and can be detected by an accurate geometrical survey. Nevertheless, the building may have had an evolution along the time: born as an isolated building (Figure 3(a)), it could have become a row building (Figure 3(b)) or a complex one (Figure 3(c)), after the addition of several volumes. The eventual discontinuities between the different volumes could affect the overall seismic behaviour (Figure 4).

The more complex the building is, the more difficult the detection of its vulnerability is; therefore, its structural evolution should be known as much as possible. The geometrical survey is not enough then, and effort should be made to find through historic documents, and also by on site observation, the modification it was subjected to along the time. All data are collected in a survey form subdivided for Minimal Unit for Intervention and building unit, useful to build a data-base for consultation at different levels of analysis.

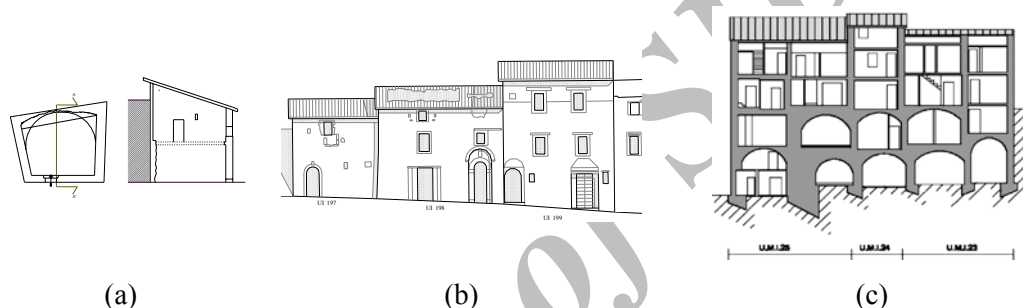

Figure 3. Example of: a) simple isolated building; b) row building; c) complex building

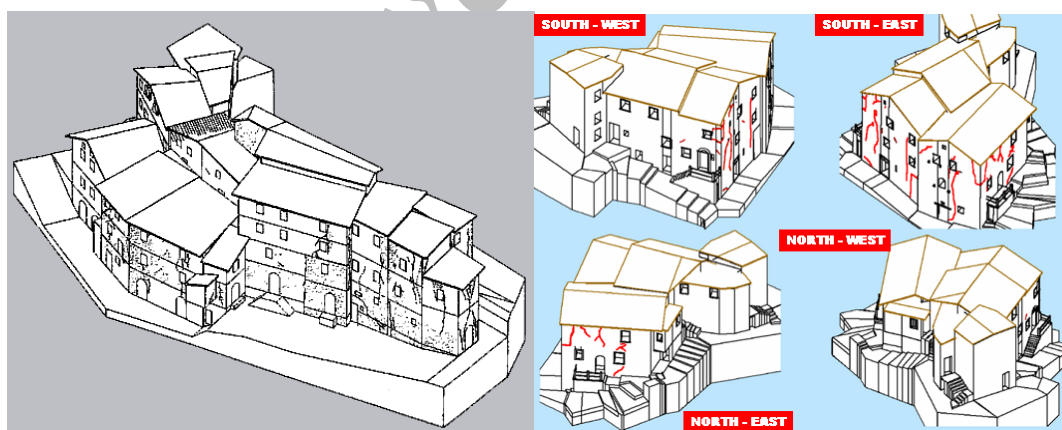

Figure 4. Examples of complex buildings

### 3. MATERIALS AND CONSTRUCTION TECHNIQUE

The structural performance of a masonry wall structure can be understood provided the following factors are known:

- its geometry;
- the characteristics of its masonry texture (single or multiple leaf walls, connection between the leaves, joints empty or filled with mortar, physical, chemical and mechanical characteristics of the components (mortar, brick, stone));
- the characteristics of masonry as a composite material.

In the case of multiple leaf masonry, the masonry texture, which strongly influences the bearing capacity of the wall, often can not be easily identified. Furthermore the characteristic strength and stiffness of a highly non-homogeneous material is difficult to be experimentally determined being the strength and deformability parameters (Young modulus, Poisson ratio) of the components not representative of the global strength and deformability of the masonry.

The worst defect of these masonry walls is that they are not monolithic in the lateral direction, and this can happen for instance when the wall is made by small pebbles or by two external layers even well ordered but not mutually connected and containing a rubble infill. This makes the wall more brittle particularly when external forces act in the horizontal direction (Figure 5). The same problem can happen under vertical loads if they act eccentrically.

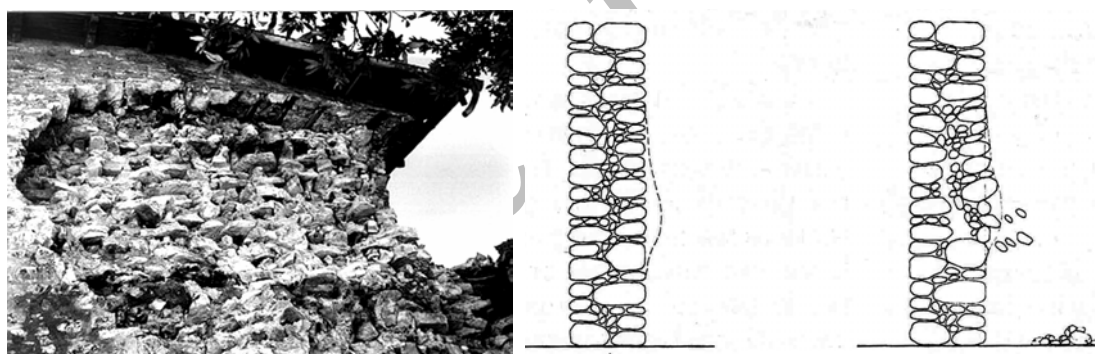

Figure 5. Collapse of the outer leaf of the wall

In order to evaluate the characteristic of the masonry a classification of the different cross sections locally recognisable should be carried out, particularly of the multiple leaf ones. Giuffrè carried out in the early '90s [3] the first studies about the mechanical behaviour of the stonework masonry typologies based on visual inspection to recognise characteristics of the "rule of art". This approach can lead to the typology classification (Figure 6) [6]. The presence of some characteristic, like the leave connection elements called diatons, can be a discriminating parameter for the evaluation of the wall mechanical behaviour.

In the proposed methodology, the masonry is surveyed by pictures (Figure 7), obtained as parallel as possible to the masonry surface, and by placing close to the section or to the texture a graduated stick in order to know the wall dimension. The dimensions are then verified by the archaeological survey method (scale 1:1). The 2D graphic plotting is realised with a special care in the representation of stones, joints and voids. Successively, the surface occupied by the different materials, which compose the masonry, is measured, evaluating

the stone, mortar and voids percentages, the dimension and the distribution of voids. This information is useful both for the definition of the geometry and mechanical behaviour necessary to the modelling phase and for the design of possible strengthening intervention (e.g. grout injection).

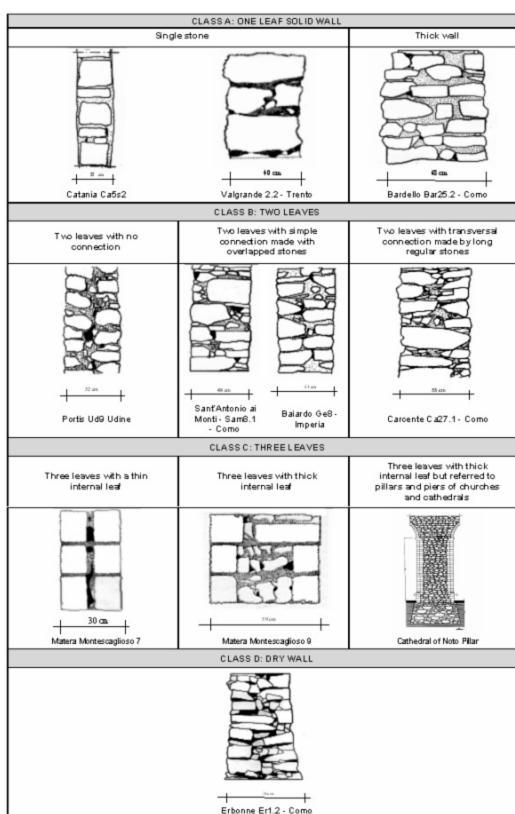

Figure 6. Example of the stonework sections

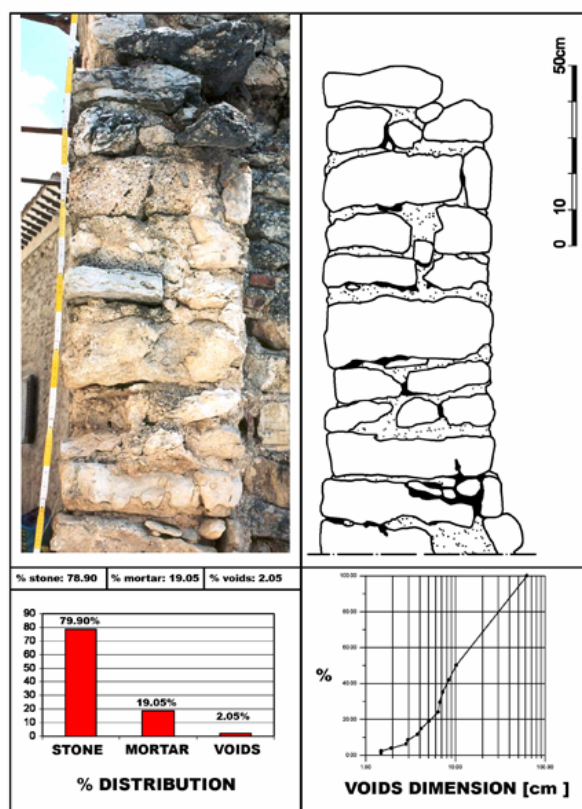

Figure 7. Survey of the masonry section

#### 4. CRACK PATTERN AND STRUCTURAL DAMAGE SURVEY, ABACUS OF COLLAPSE MECHANISMS

The survey and drawing of the crack patterns is peculiarly important. The interpretation of the crack pattern can be of great help in understanding the state of damage of the structure, its possible causes and the type of survey to be performed, provided that the development history of the building is already known.

Damages, which are frequently attributed to the earthquake, can have a different nature and can be caused by excessive dead load or soil settlements, or simply to lack of maintenance. A complete survey of the structural and physical damages can help in understanding the vulnerable points of the structure and also the possible future mechanisms

as it is described in the following section.

The interpretation of failure or damage mechanisms in the case of large complexes of buildings, attached together to form a sort of curtain and/or built on steep slopes, is particularly complex. Blocks or parts of buildings may be identified and surveyed, also adopting axonometric representations (Figure 4), which can also show the different levels of the ground soil, in order to single out their typical failure mechanisms. Normally, buildings placed at the free ends of a complex are less constrained and therefore more severely damaged, with local collapses and large cracks. When collapses occur in the internal part of a complex they generally affect non repaired building units, adjacent to repaired ones. In the central part of arrays of buildings with presence of decayed floors and roofs, large continuous deformations and tilting of the walls are generally detected. Where vaulted passages connect two blocks of buildings, cracks and damages appear due to the hammering of the two blocks, particularly when only one of them was repaired. Once the damage mechanisms have been singled out and defined, appropriate calculations should be adopted for modelling the observed behaviour, which is one of the most difficult tasks, due to the complexity of the structure.

The stratigraphical method [7] allows subdivision of the building into homogeneous blocks, characterised by relative chronological relationships. Any block corresponds to a unique building phase (Figure 8), recognized by the observation of constructive details; its relationship with the other blocks may be “preceding” or “subsequent”, often with no possibility of an absolute dating. Critical connections between blocks need to be investigated, so to clarify the phases of expansion and transformation of the complex. The study can be then completed by the investigation of dated elements like the brick type and dimensions and by the chronological characterization of the construction techniques and masonry details, beyond the survey and characterization of the different masonry typologies.

## **5. USE OF AN ABACUS AND INTERPRETATION OF THE CRACK PATTERN**

The assessment of seismic vulnerability of masonry buildings requires the identification of the damage and collapse mechanisms activated by the earthquake. The current practice in Italy is to take account of only a limited number of modes of failure; some of them are neglected implicitly, assuming a strength capacity of certain structural typologies, after appropriate retrofitting measures.

On the contrary, the possibility of damage prediction is related to the knowledge of the highest number of possible mechanisms of progressive deterioration or sudden failure. The extensive survey carried out by the authors together with other researchers in Umbria after the 1997 earthquake (Figure 9) allowed to set up an abacus of failure mechanisms referred to different building typologies, and depending upon if the building had been repaired. In Figure 10 some examples are given of the different mechanisms [8]. The adopted diagnostic approach is based on the recognition of local and global collapse mechanisms traceable to in-plane or out-of-plane seismic action. The modelling of the structure behaviour and its safety assessment by macro-elements can highly benefit of the abacus, provided that the

characteristics of the materials and the structure are known. The vulnerability assessment by macro-models has been already applied to the evaluation of the damage of churches [9] and to study small scale urban contexts in historic centres [3].

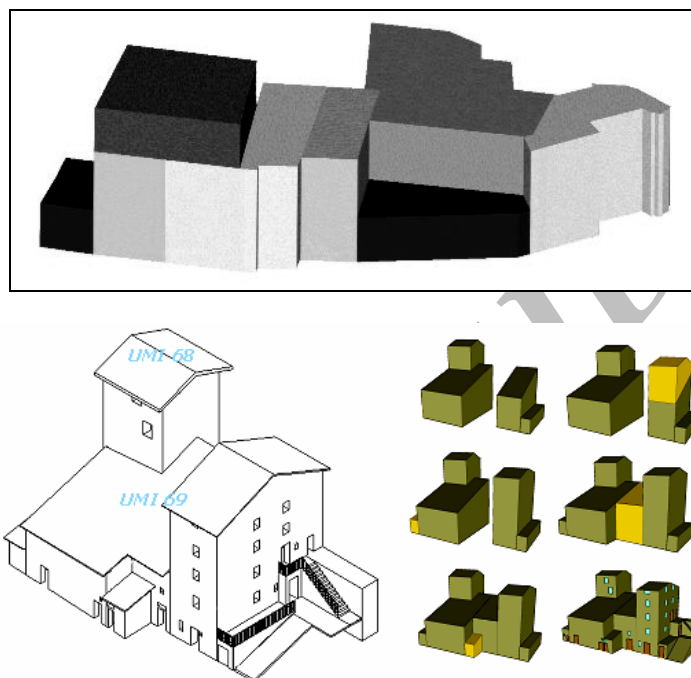

Figure 8. Constructive evolution phases of a complex buildings

## 6. ON SITE AND LABORATORY INVESTIGATION

As previously mentioned since it is impossible to carry out on site and laboratory tests on every building, when working at a urban scale (even if small centre), a “minimal” investigation is suggested by this multi-level approach in order to know by sampling from buildings representative of the whole.

The aim is to identify the different materials used for the masonry walls and their mechanical and physical behaviour. This investigation is also useful to detect compatible materials and techniques for prevention and repair [10]. On the basis of the geometric and material surveys of the single buildings and of the surveys of the crack patterns, the following in situ and laboratory tests should be carried out on strategic points as a minimum level of investigation of: 1) flat jacks tests; 2) sonic tests; 3) sampling of materials for their chemical-physical-mechanical characterisation.

The recommended tests represent the minimum level for the knowledge of masonry, particularly in cases of shortage of funds, but placed in strategic positions for the study of the vulnerability of the historic centre.



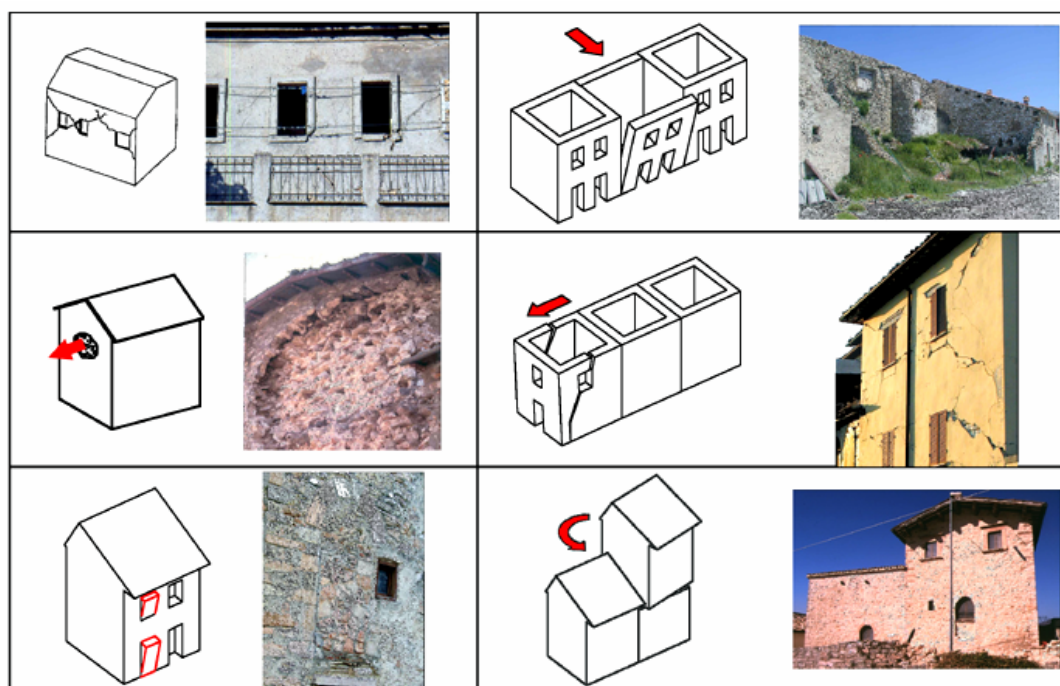

Figure 10. Some examples from the collapse mechanisms abacus

Samples of mortar and of some of the most recurrent stone materials should be analysed. Mechanical-physical tests and chemical analyses have been carried out. Chemical and mineralogical-petrographical analyses are useful (and less expensive than other more sophisticated tests) to determine: the type of binder and of aggregate, the binder/aggregate ratio, the extent of carbonation, the presence of chemical reaction, which produced new formations (pozzolanic reactions, binder-aggregate reactions, alkali-aggregate reactions) [11]. Cylindrical specimens could be cored from the stones to be tested mechanically in dry and saturated conditions in two directions. The presence of salts and/or the stone origin should be evaluated.

## 7. SEISMIC VULNERABILITY ANALYSIS

The methodology proposed for assessment of seismic vulnerability of existing buildings in historical centres concerns the application of simply kinematics models able to describe the mechanical behaviour of structural components and assemblages (macro-models) [3], [4], [5], [9], both for in-plane and out-of-plane collapses.

Automatic procedures have been implemented recently in Visual Basic ambient at the University of Padova (Vulnus VB release and C-Sisma program), which allow to execute vulnerability assessment for whole centres more quickly in comparison to the first applications. The Vulnus methodology is able to define two indexes, I1 and I2 [5], concerning the in-plane

shear resistance and out-of-plane collapse mechanisms, respectively. It is able to combine different mechanisms for global vulnerability analyses of buildings with sufficient regularity (both in plane and in elevation) and limited height (three storeys or less), and take into account the type of connection among the structural elements. The significant parameter describing the kinematics models is the collapse coefficient  $c=a/g$ , which corresponds to the seismic masses multiplier characterizing the limit of the equilibrium conditions for the considered element. Preliminarily, if the seismic degree of the zone is given, it is possible to execute safety assessments of the buildings in seismic conditions according to the current standards prescriptions (e.g.  $c_{min}=0.28$  for the Umbria region). Some examples of kinematics models and related  $c$  coefficients are given in Figure 11.

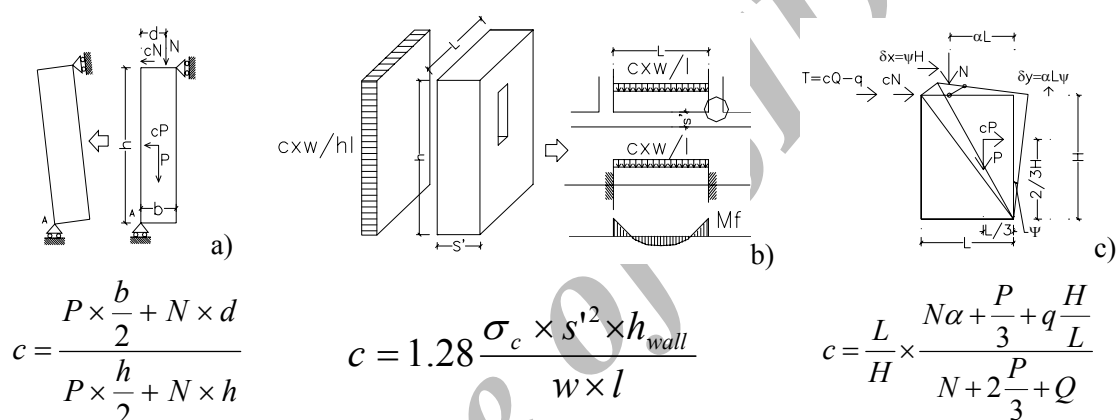

Figure 11. Examples of simple kinematics models for out-of-plane (a: overturning of a solid wall) (b: crushing of the masonry) and in-plane mechanisms (c: effect of in-plane overturning actions)[8].

The proposed procedures, applied to different typologies of buildings (isolated, rows and complexes), showed their reliability in comparison with systematic adoption of typical assessment methods based on the “box behavior” of the structure, which take into account only the in-plane shear strength of the masonry panels composing the walls, as also suggested by Italian standards until now [12]. Finally, recent further updating of the seismic code are going to take into account the high vulnerability of existing masonry buildings not satisfying assumptions commonly directed to new earthquake-proof structures, towards preventive loss of equilibrium of structural portions, before any collaboration among elements can activate the material ultimate capacity.

Isolated buildings are well described in their structural conditions by the simplified macromodelling [9], [13]; for buildings characterized by more adjacent constructions (rows, complex) the general procedure for the vulnerability assessment is to perform first of all the global analysis and to control some local aspect by using the single kinematics models [3], [14]. In particular, for arrays of buildings and particular irregular configurations, both in plan and in section, as frequently found, the subdivision in homogeneous units (respect to dating, transformations, etc. and regardless the possible different private properties), is necessary.

However, the critical analysis of the results obtained at general level is essential [13].

### 8. APPLICATION OF THE METHODOLOGY TO CAMPI

Campi di Norcia (Figure 12) was a late medioeval castle perched on a slope surrounded by walls, and whose buildings are arranged in concentric terraces and narrow streets connected by short radial flights [8]. The only type of building observed in the area is the single family house with two or more floors, built with a simple technique in stonework and timber roof and floor. More complex buildings are derived only by different aggregations of this typology (Figure 13): isolated buildings, row buildings simple or double, block buildings. Due to the ground slope (more than 100 meters from the base to the top of the village), buildings develop following a row typology generally with three floors: the first one with an entrance at the lower street (for stables or deposits), one in the middle and the last with the entrance at the upper street (for living places). The lowest floor is partially excavated in the natural rock. The rooms are covered by barrel vaults, that, despite the several seismic events, are still well preserved even in the collapsed buildings. A detail observed in almost all buildings is that the vaults are backward from the facade of about 1 meter (Figure 13): the reason of that is still unknown. The numerous past seismic events deeply marked this historic centre together with the lack of maintenance throughout the last decades after the second world war.



Figure 12. View and plan of Campi

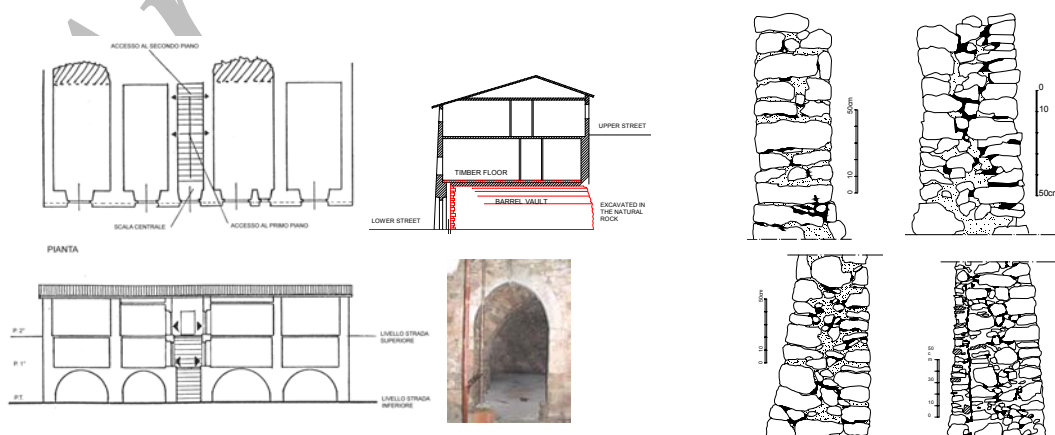

Figure 13. The row buildings typology of Campi Alto and some typical wall cross sections [8]

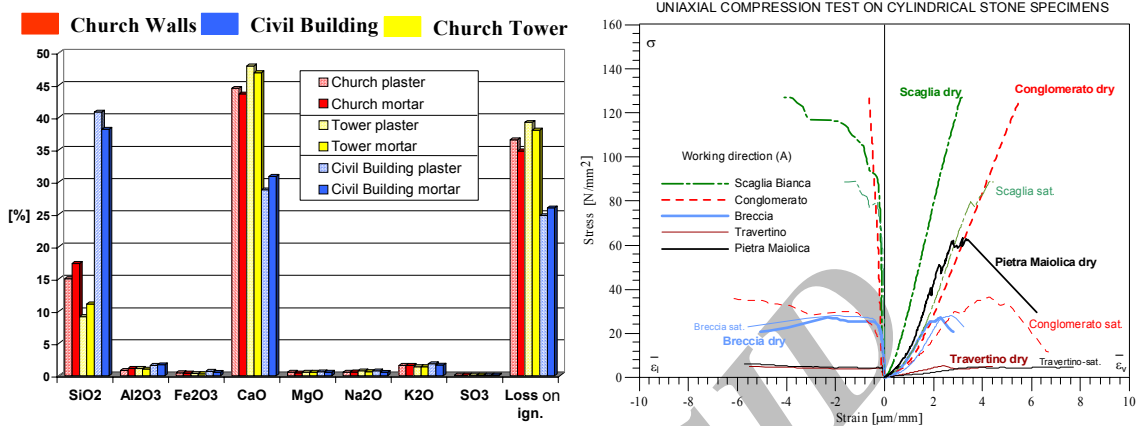

Figure 14. Some results on mortars and stones specimens sampled from Campi [8].

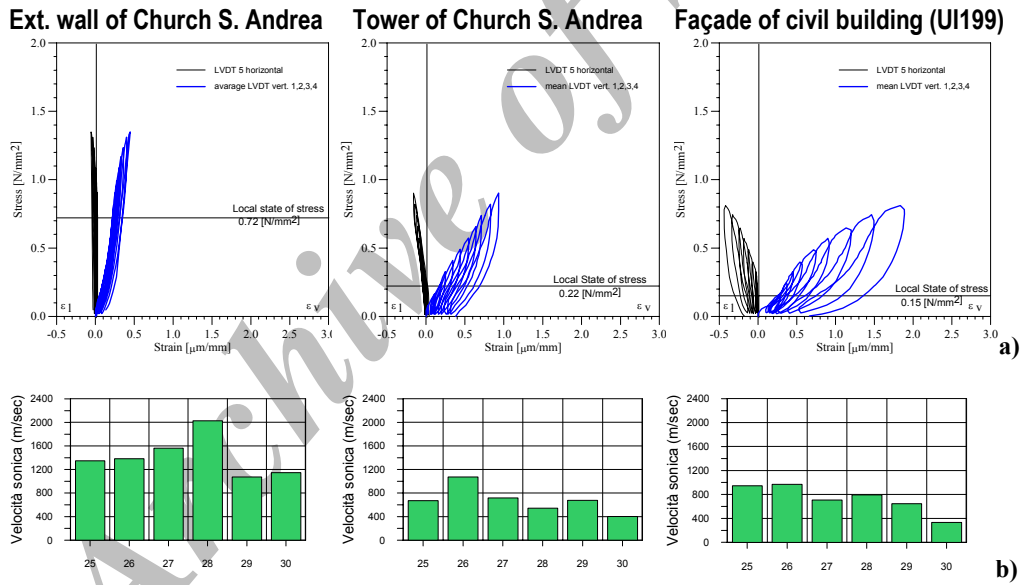

Figure 15. Results obtained with single and double flat-jack tests (a) and the corresponding results of the diagonal surface sonic measurements (b) on: the external wall of a church (left), of a bell tower (middle) and of a civil building (right).

Figure 13 shows some example of masonry section. The stones are mainly limestone and travertine, laid in courses with stone ashlar and rough cut stones. The dimension varies from 5 to 25 cm. In some cases also sandstone is present. The mortar joints height is very variable, from 1 cm up to 5 cm, due to the irregularity of the stones. Mortar is compact with colours varying from white to yellow and grey. The sampled mortars have revealed a high presence of lime pebbles that (as the chemical analysis have confirmed) means putty lime as

binder. The aggregate is mainly calcareous and the ratio binder-aggregate may be stated around 1:2 1:2,5. Cylindrical specimens were cored from the stones to be tested mechanically in dry and saturated conditions in two directions.

In Figure 14 some results of compression tests carried out on four types of stones sampled on site are shown (white and pink calcareous stone, sandstone and travertine). From the plot it is very clear the difference between the *scaglia* (limestone) strength and the *travertine* strength. This explains the higher use of the *scaglia* in the walls and the use of travertine only for lintels and vaults. Nevertheless in a more recent past when the “rules of art” were lost, the *travertine* was more and more used also in the wall construction both as irregularly or regularly cut elements.

In Figure 15 the results of the tests with simple and double flat jack carried out on some sample buildings of Campi are reported. The results allow to see the different behaviour between the masonry of the important buildings or of complex structures (church or the bell tower) and the private or poor buildings. At the same time it is possible to compare the sonic velocity values (Figure 15(b)) measured in the same areas where the flat jack test has been carried out. As an example it is possible to see that the dwelling masonry is the weakest one (UI199) both for flat jack and sonic test.

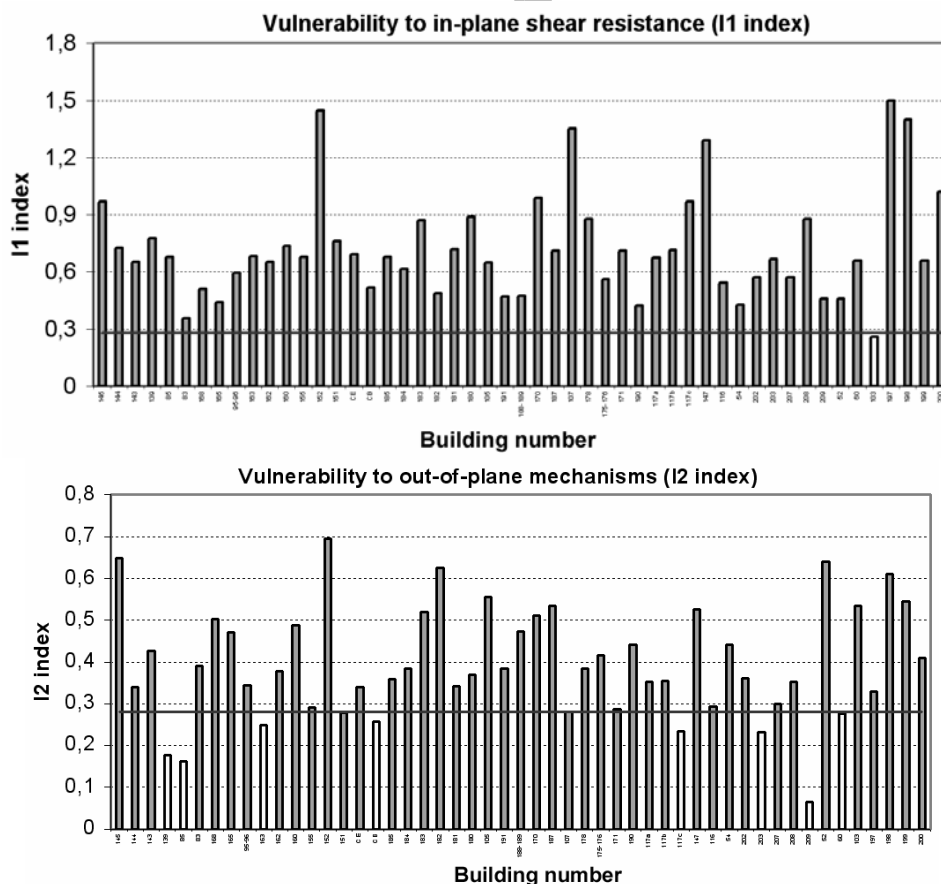

Figure 16. Results obtained by “Vulnus” for the whole centre of Campi: seismic vulnerability

assessment expressed by I1 and I2 indexes. The limit imposed by the Italian seismic standard is 0.28.

Results of the application of Vulnus on the whole center of Campi are depicted in Figure 16. As expected, for all the buildings (except one) the safety is not affected by the shear resistance of masonry panels, whereas main problems are related to out-of-plane mechanisms. About the 25% of buildings present an I2 index lower or very close to the limit imposed by the standards (0.28). The weakest mechanisms are related to the global overturning of façades and overturning of corners.

## 9. CONCLUSIONS

The methodology applied to the four centres is now well calibrated and can be used for other similar cases. The research allowed to detect three main diffused construction typologies: isolated houses, row of buildings and complex aggregates, and to show that for the last typology a still hard work has to be made concerning structural behaviour, failure mechanisms, structural analysis and hence choice of appropriate repair techniques [15], [16].

**Acknowledgments:** The authors wish to thank M. Antico, M. Cucchi, M. Iscandri, L. Cantini and C. Arcadi for their collaboration during the experimental works. The research was supported by GNDT.

## REFERENCES

1. Penazzi, D., Valluzzi, M.R., Saisi, A., Binda, L. and Modena, C., Repair and strengthening of historic masonry building in seismic area, *Proc. Int. Millennium Congress 'More than two thousand years in the history of architecture safeguarding the structure of our architectural heritage'*, Bethlehem, 2(2001) Section V, pp. 1-7.
2. Binda, L., Cardani, G., Penazzi, D. and Saisi, A., Performance of some repair and strengthening techniques applied to historical stone masonries in seismic areas, *Proc. Int. Conf. on Performance of Construction Materials*, Cairo, February 2003, pp. 1195-1204.
3. Giuffrè, A., Sicurezza e conservazione dei centri storici. Il caso Ortigia, Laterza, 1993, Bari.
4. Bernardini, A., Gori, R. and Modena, C., *Valutazioni di resistenza di nuclei di edifici in muratura per analisi di vulnerabilità sismica*, Report 2/88, University of Padova, Istituto di Scienza e Tecnica delle Costruzioni, 1988, Padova.
5. Bernardini, A., Gori, R. and Modena, C., Application of coupled analytical models and experiential knowledge to seismic vulnerability analyses of masonry buildings, on: *Earthquake Damage Evaluation and Vulnerability Analysis of Buildings Structures*, A. Kortize Ed., INEEC, Omega Scientific, 1990, Oxon.
6. Binda, L., Penazzi, D. and Saisi, A., Historic Masonry Buildings: necessity of a classification of structures and masonries for the adequate choice of analytical models, *6<sup>th</sup> Int. Symp. Computer Methods in Structural Masonry*, Roma, September 2003, pp. 168-173.

7. Mannoni, T., *Caratteri costruttivi dell'edilizia storica*, Sage, 1994, Genova.
8. Cardani, G., *La vulnerabilità sismica dei centri storici: il caso di Campi Alto di Norcia. Linee guida per la diagnosi finalizzata alla scelta delle tecniche di intervento per la prevenzione dei danni*, Ph.D. thesis, Politecnico di Milano, 2004, Milano.
9. Doglioni, F., Moretti, A. and Petrini, V., *Le chiese e il terremoto. Dalla vulnerabilità constatata nel terremoto del Friuli al miglioramento antisismico nel restauro, verso la politica di prevenzione*, LINT, 1994, Trieste.
10. Binda, L., Saisi, A. and Tiraboschi, C., *Investigation procedures for the diagnosis of historic masonries*, *Construction and Building Materials*, June 2000, pp. 199-233.
11. Baronio, G. and Binda, L., *Experimental approach to a procedure for the investigation of historic mortars*, *9<sup>th</sup> Int. Brick/Block Masonry Conf.*, Berlin, 1991, pp. 1397-1464.
12. Valluzzi, M.R., Michielon, E., Binda, L. and Modena, C., *Modellazione del comportamento di edifici in muratura sotto azioni sismiche: l'esperienza Umbria-Marche*, *10<sup>th</sup> Conf. ANIDIS, L'ingegneria sismica in Italia*, Potenza, September 2001.
13. Valluzzi, M.R., Cardani, G., Binda, L. and Modena, C., *Analysis of the seismic vulnerability of masonry buildings in historical centres and intervention proposals*, *6<sup>th</sup> Int. Symposium on the Conservation of Monuments in the Mediterranean Basin*, Lisbon, Portugal, April 2004, pp. 561-565.
14. Valluzzi, M.R., Cardani, G., Binda, L. and Modena, C., *Seismic vulnerability methods for masonry buildings in historical centres: validation and application for prediction analyses and intervention proposals*, *13<sup>th</sup> World Conf. on Earthquake Engineering*, Vancouver, B.C., Canada, August 2004.
15. Binda, L., Cardani, G., Saisi, A., Modena, C. and Valluzzi, M.R., *Multilevel approach to the analysis of the historical buildings: application to four centers in seismic area finalised to the evaluation of the repair and strengthening techniques*, *13<sup>th</sup> Int. Brick and Block Masonry Conference*, Amsterdam, July, 2004.
16. L. Binda, G. Cardani, A. Saisi, C. Modena, M.R. Valluzzi and L. Marchetti, *Guidelines for restoration and improvement of historical centers in seismic regions: the Umbria experience*, *IV Int. Seminar Structural Analysis of Historical Constructions*, Padova, November, **2**(2004) 1061-1068.