

Effects of Disc Insulator Type and Corona Ring on Electric Field and Voltage Distribution over 230-kV Insulator String by Numerical Method

E. Akbari*, M. Mirzaie*, M. B. Asadpoor* and A. Rahimnejad*

Abstract: Insulator strings with several material and profiles are very common in overhead transmission lines. However, the electric field and voltage distribution of insulator string is uneven which may easily lead to corona, insulators' surface deterioration and even flashover. So the calculation of the electric field and voltage distribution along them is a very important factor in the operation time. Besides, no remarkable endeavor regarding insulator material and profile and their impacts upon the electric field and voltage distribution has been made so far. In this paper several 230-kV insulator strings with different porcelain and glass units were simulated using 3-D FEM based software, and their electric fields and voltage distributions were calculated and compared together, to investigate the effect of insulator types on these quantities. Tower and conductors were included in all simulations and also the effect of corona ring on voltage and electric field distribution over insulator strings with different insulator types was investigated. Reported results show the dependency of voltage distribution to insulator material and profile.

Keywords: Electric Field and Voltage Distribution, Finite Element Method (FEM), Porcelain and Glass Disc Insulators.

1 Introduction

Insulators are widely used in electrical power systems to provide electrical insulation property and mechanical support for overhead transmission lines and insulator strings are also very common due to their high mechanical strength, easy installation and operation, and low cost. The number of units of an insulator string depends on several factors such as operation voltage, mechanical strength, sea level (of alignment), lightning strength, and contamination level of the environment [1].

Due to the coupling capacitance between disc insulators and conductors around them, the potential distribution of insulator string is uneven greatly. The voltage and electric field on the insulators near conductors is three to five times greater than others (without corona ring), which may easily lead to corona, insulators' surface deterioration and even flashover. And these problems will seriously affect the operation safety of transmission lines [2]. So the calculation of the

electric field and voltage distribution in and around high voltage insulators is a very important factor in the operation condition. The excessive electric stress on the disc insulators near to energized conductor leads to insulator ageing and surface discharges. Furthermore, the knowledge of the electric field is useful for the detection of defects in insulators [3].

Several circuit methods for calculating potential distribution were studied in [4]. Izgi et al. [5] used circuit method for calculating voltage distribution over insulator string depending on atmospheric conditions such as wind and contamination; but these methods could not analyze electric field distribution. Also, in [6], the equivalent circuit model (lumped model) of insulator string with insulator unit self capacitances, capacitances between each unit and ground and capacitances between each unit and conductor has been explained. Then voltages across each insulator are determined by solving the differential equation of the circuit. In this method, all of the capacitances of each mentioned category are considered the same, which is not a good assumption. Methods based on field theoretical approach were reviewed in [7], which indicated its advantages in the analysis of electrical insulation problems. However, the electric field evaluation of a practical insulator is so complex that an analytical method is very difficult, if not possible, to

Iranian Journal of Electrical & Electronic Engineering, 2013.

Paper first received 29 May 2012 and in revised form 25 Feb. 2013.

* The Authors are with the Department of Electrical and Computer Engineering, Babol University of Technology, Babol, Iran.

E-mails: e.akbari@stu.nit.ac.ir, mirzaie@nit.ac.ir,
mb.asadpoor@stu.nit.ac.ir and a.rahimnejad@stu.nit.ac.ir.

compute the exact solutions. Numerical methods are thus often adopted in engineering applications to derive acceptable solutions. Wei et al. [8] applied Charge Simulation Method (CSM) to calculate potential and electric field distribution along insulator strings, but they simplified the problem which could not include the influence of conductors or towers. A Finite Difference Method (FDM) to calculate the electric field in and around polluted insulators with asymmetric boundary conditions has been proposed by Morales et al. [9]. Zhao et al. [10] applied Boundary Element Method (BEM) in calculating the potential and electric field distribution along insulators. Their method considered the effects of conductors, grading devices and transmission towers. But computational requirements were high.

Finite Element Method (FEM) was applied in calculating potential and/or electric field distribution along insulators in [11-13]. In [10] a two-dimensional (2-D) FEM was used for simulation of electric field distribution on ceramic insulators. In [12] Ashouri et al. used FEM-based software, Maxwell 3-D for investigating the wind effect on the potential distribution of an insulator string. Reddy et al. [13] used FEM-based software to study the potential and electric field distribution of different types of porcelain disc insulators; but their method was 2-D and could not consider the supporting structures, conductors and other accessories.

In this paper several insulator strings with different disc insulators were simulated using a three-dimensional (3-D) electric field program based on finite element method. The electric field and potential distributions along insulators were calculated and compared for different insulator types. The effects of tower and conductor existence were considered. Also the effect of corona ring, for reduction of maximum electric field and improving voltage distribution, was investigated.

2 Parameters of Insulators, Grading Ring, Tower and Conductors

The investigations were carried out on three types of porcelain disc insulators and three types of glass disc insulators, which were denominated by type-A to type-F, respectively. Technical parameters of the insulators are introduced in Fig. 1 and given in Table 1, in which H is the configuration height, D is the diameter, L is the leakage distance and F_{min} is minimum mechanical failing load. Also profiles of different insulator types are shown in Fig. 2 which between them type-B and type-E are fog-type insulators, with greater leakage distance, and others are standard ones.

The length of the conductor, which was used for the simulation of the model, was chosen to be equal to the insulator string length. Tower height was 5000 mm and cross-arm length was 3175 mm, and finally one of the

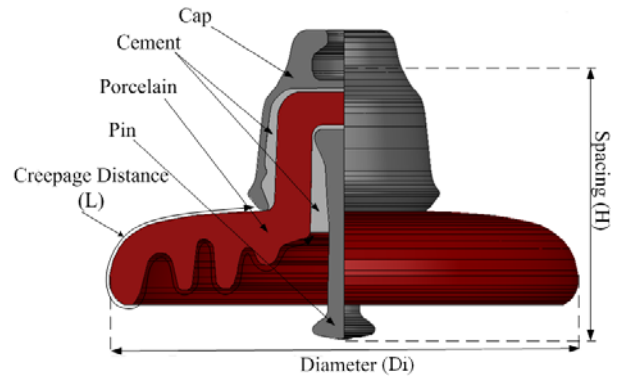

Fig. 1 Dimension parameters and material types of one of the simulated insulators

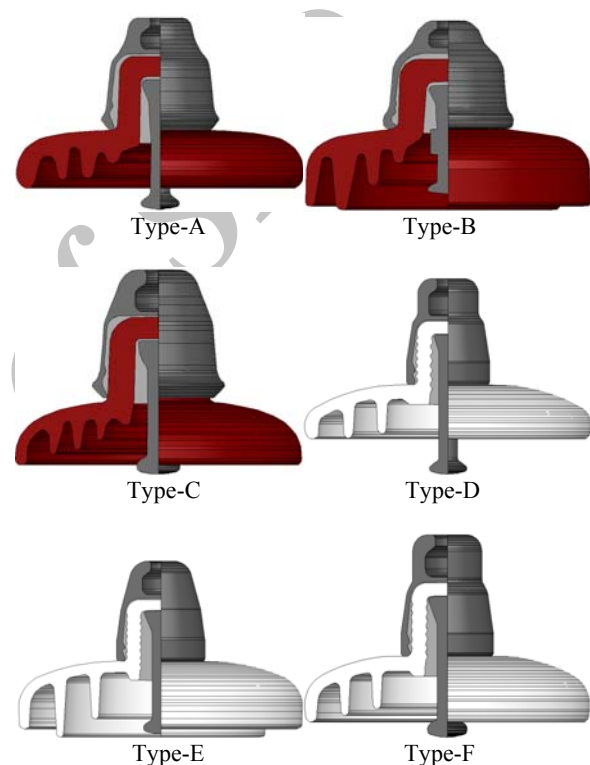

Fig. 2 Profiles of the simulated insulators

common types of corona rings in 230-kV power transmission lines was selected for the investigations, whose profile and dimensions are shown in Fig. 3. The ring center is 35 mm away from string axis.

Table 1 Technical parameters of the simulated insulator

No.	Type	Material	H (mm)	Di (mm)	L (mm)	Fmin (kN)
A	0207	Porc.	146	255	295	120
B	0215	Porc.	146	255	440	120
C	0206	Porc.	170	280	370	160
D	U120B	Glass	146	255	320	120
E	U120BP	Glass	146	280	442	120
F	U160BL	Glass	170	280	370	160

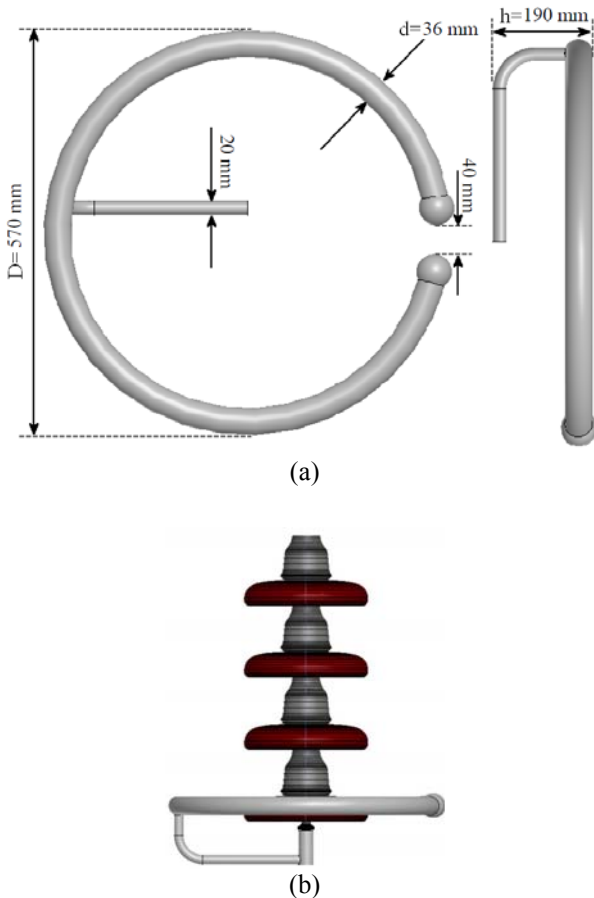

Fig. 3 Schema of simulated corona ring (a) profile and dimensions (b) installation configuration

3 Potential and Electric Field Distribution over Insulator String

As mentioned before voltage and electric field distribution of insulator string is uneven because of the effects of stray capacitive currents. This phenomenon can lead to corona discharge on insulator surface and therefore should be considered before insulator usage. The uniformity degree of voltage distribution depends on insulator unit capacitance, the number of units, cross-arm length and corona ring parameters.

String efficiency (η) is used to determine the level of uniformity of voltage distribution of insulator string. The formula is:

$$\eta = \frac{U}{n \cdot U_{\max}} * 100 \quad (1)$$

where U is phase-neutral voltage over insulator string, U_{\max} is the maximum voltage drop on a single disc in insulator string, n is the number of insulator units, and η is the percentage of string efficiency. For better studying of voltage distributions all values of voltages was normalized as following:

$$\%U_i = \frac{U_i}{(230/\sqrt{3})} * 100 \quad (2)$$

where U_i is the voltage of i -th unit in kV and $\%U_i$ is the normalized voltage of the same unit in %. In this paper, insulator units are enumerated from energized side to grounded side of the string.

4 3-D Simulation Results

One of the numerical methods for electromagnetic simulations is FEM. Now FEM is being widely used in electrical engineering as a main numerical calculation method for quantifying and optimizing the performance of an insulator under electro-magnetic fields [14].

The finite element method for any problem consists of, basically, discretizing the solution domain into a finite number of elements, deriving governing equations for a typical element, assembling of all elements in the solution domain, and solving the system of equations.

High voltage apparatus, including outdoor insulators, lie in the domain of the electrostatics application modes. The 'statics' implies that the time rate of change is slow, and that wavelengths are very large compared to the size of the domain of interest, in this case an outdoor insulator [15].

The boundary problem of the 3-D electrostatic-field FEM is expressed as Eq. (3) with being the electric potential [15].

$$\begin{cases} \frac{\partial^2 \phi}{\partial x^2} + \frac{\partial^2 \phi}{\partial y^2} + \frac{\partial^2 \phi}{\partial z^2} = 0 & \text{B1} \\ \phi|_{S_0} = \phi_0 & \text{B2} \\ \phi_1 = \phi_2, \epsilon_1 \frac{\partial \phi_1}{\partial n} = \epsilon_2 \frac{\partial \phi_2}{\partial n} & \text{B3} \\ \iint_{S_i} \epsilon \frac{\partial \phi}{\partial n} dS = 0, \phi|_{S_i} = \phi_i & \text{B4} \end{cases} \quad (3)$$

where boundary condition B1 is true in the whole region, B2 is known potential boundary, B3 is the boundary condition on the interface of different mediums and B4 is floating potential boundary. ϕ_0 is $230/\sqrt{3}$ kV on the high voltage terminal, conductor and corona ring, and 0 V on the lower voltage terminal and iron tower. Cap and pins with unknown potentials must be set as floating potential boundaries. For high voltage insulator string problems considering effects of tower and conductor, there is no symmetry plane. The numerical analysis method was introduced in [11, 12] with more detail.

The 3-D model simulated in FEM, which consists of the insulator string, corona ring, the transmission line and also simplified tower, is shown in Fig. 4.

To investigate the effect of insulator type and profile on electric field and potential distribution, simulation of insulator strings in different conditions has been carried out by software based on FEM and results were presented. Because of the large number of simulations carried out, only some results of type-A insulator string

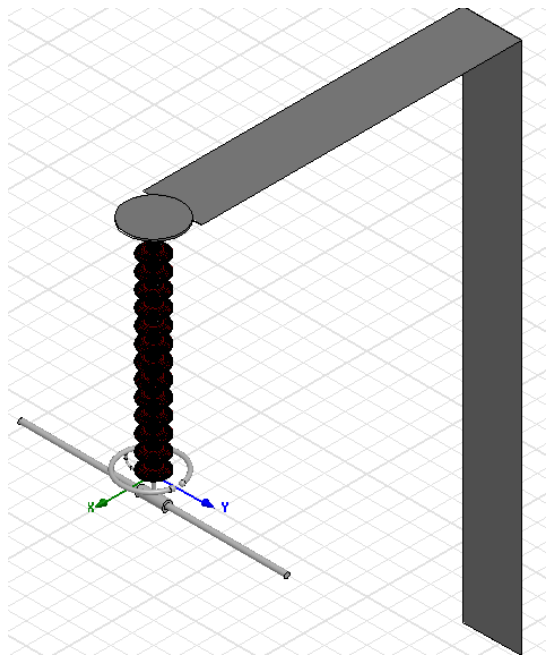

Fig. 4 The model of tower, conductor, and insulator string used for simulation

were extracted from FEM software and is presented here as a sample. Results of other insulator types are discussed through appropriate figures.

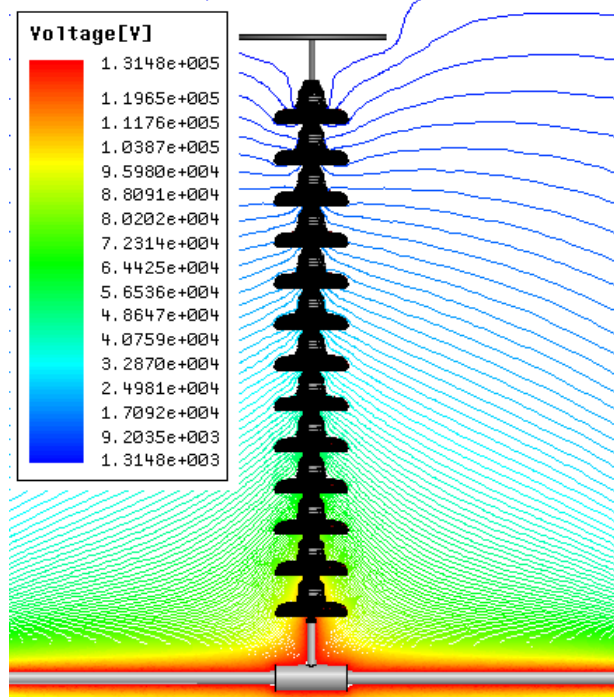
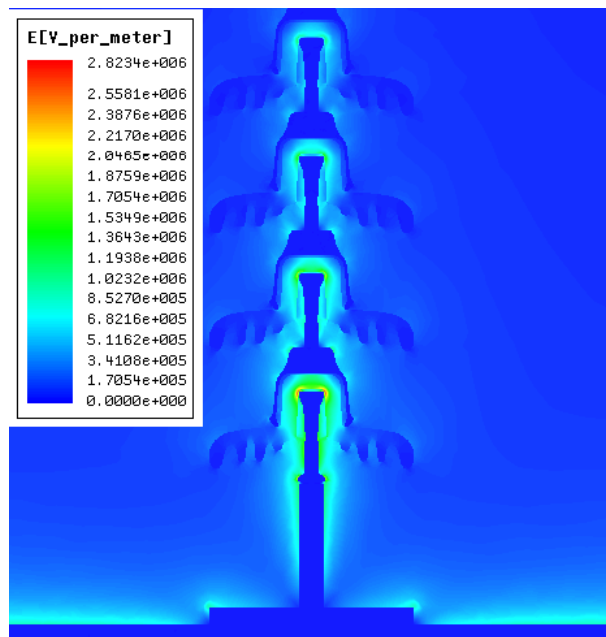
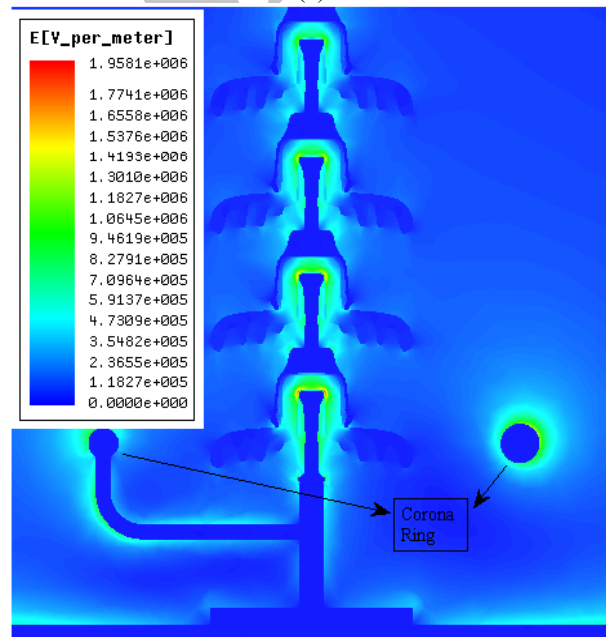

Fig. 5 The equipotential contours around a 230-kV for type-A insulator string



(a)



(b)

Fig. 6 Electric field distribution on YZ plane for type-A insulator string (a) without corona ring (b) with corona ring

The equipotential contours around 230-kV type-A insulator strings consisting of 13 insulator units are shown in Fig. 5. The electric field distribution on YZ plane for type-A insulator strings without and with corona ring are presented in Fig. 6. It is obvious from these figures that the triple junctions (pin-cement, cement-porcelain) are critical areas where electric field stress is maximum and damage and consequent breakdown may occur, especially for the bottom insulator disc. The electric field plot along the line that

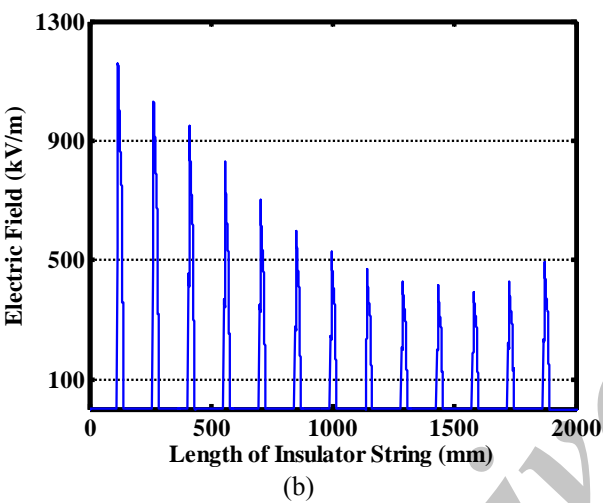
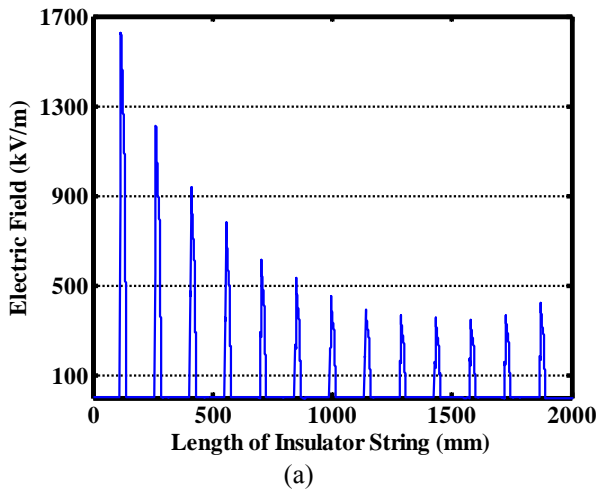

Fig. 7 Electric field plot on string axis for type-A insulator string (a) without corona ring (b) with corona ring

passes the center of the insulators, the string axis, for type-A insulator strings without and with corona ring are shown in Fig. 7. In these figures, the electric field within metal parts (cap and pin) is zero and sharp local maximums represent the areas where the line passes through cement and porcelain.

4.1 Effects of Transmission Tower and Conductor

In order to investigate tower and conductor effects on voltage distribution, a string of 13 insulator units of type-A was simulated with and without tower and conductor, and results of normalized voltage distribution were presented in Fig. 8. In this simulation, the length of the conductor has been considered equal to insulator string length. As can be seen, the difference between two curves is too high. So it is deduced that 2-D methods are not suitable for simulation of insulator strings, in which asymmetric equipment like tower and conductors are included. Thus hereafter a model of tower and conductor with pre-mentioned dimensions (section 2) is included in all simulations.

4.2 Effects of Types of Insulator Units

Normalized voltage distributions and efficiency for insulator strings with 13 units of types A-F are given in Fig. 9-a. Local maximums of electric field along axis of these strings are given in Fig. 10-a. These results obtained considering tower and conductor existence. It is obvious from these results that, the bottom insulator which is connected to high voltage conductor, bears the maximum voltage drop and maximum electric field which makes it first vulnerable for damage and subsequent breakdown. Also it can be found that the type of insulator is a determining factor for voltage electric field distribution. Furthermore, it is comprehended that, glass insulators which have greater capacitance values yield higher string efficiency but because of higher permittivity of glass, values of electric field is much higher along them.

4.3 Effects of Corona Ring Existence on Different Insulator Strings

To investigate the effects of corona ring existence on voltage and electric field distribution and string efficiency, the introduced corona ring was added in all of the simulations of the previous section and new results were given in Figs. 9-b and 10-b, respectively. Comparing Figs. 9-(a, b), it is obvious that, using an appropriate corona ring can significantly improve the voltage distribution. Also comparing Figs. 10-(a, b), it is comprehended that the maximum value of electric field along an insulator string significantly decreases using this apparatus. Furthermore, comparing efficiency values for strings without and with corona ring, and considering dimensions and materials of insulators from Table 1, it can be deduced that the degree of improvement of voltage distribution using corona ring depends on insulator material and profile, as well as the corona ring configuration parameters.

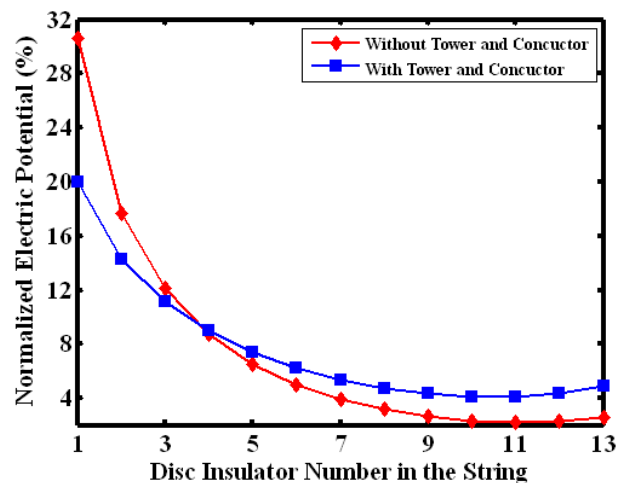
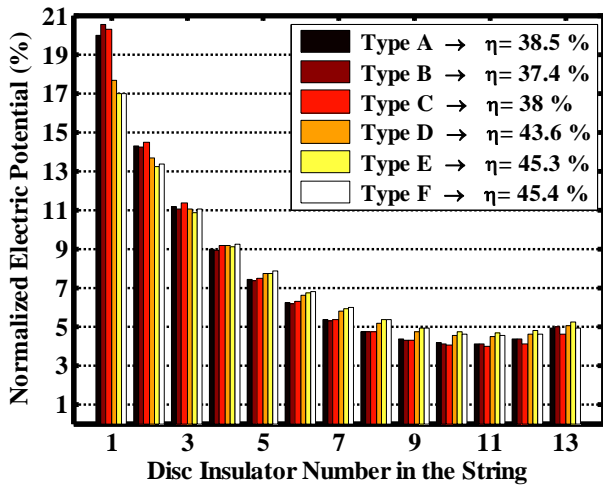
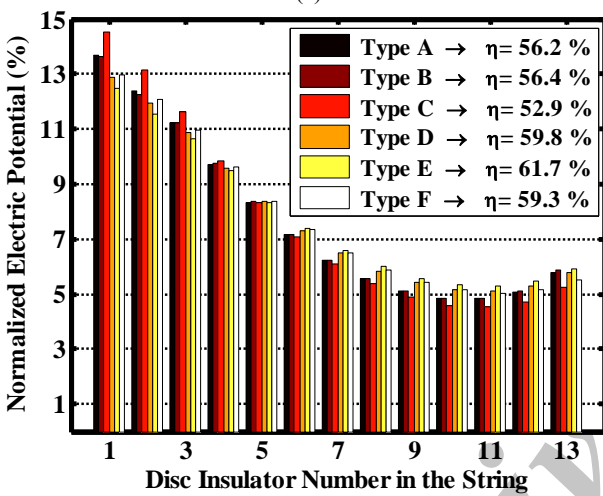

Fig. 8 Comparison of normalized electric potential distribution of a type-A insulator string for simulations without and with tower and conductor



(a)



(b)

Fig. 9 Normalized electric potential distribution and efficiency for different types of insulator strings both in % (a) without corona ring (b) with corona ring

4.4 Effects of Corona Ring Dimensions

In order to study the effect of corona ring dimensions on voltage and electric field distribution and string efficiency, the ring diameter (D), diameter of the ring tube (d), and vertical position of the ring along the insulator string (h) of the introduced corona ring placed on a type-A insulator string are altered to several values and results of normalized electric potential and electric field are given in Figs. 11 to 16, respectively.

It is deduced from Figs. 11 and 12 that the diameter of the corona ring (D) has a slight effect on voltage and electric field of the bottom unit but as it is increased, these quantities increase on top units. Also it is deduced from Figs. 13 to 16 that the diameter of the ring tube (d) and vertical position of the ring along the insulator (h) has obvious effects on voltage and electric field of all units.

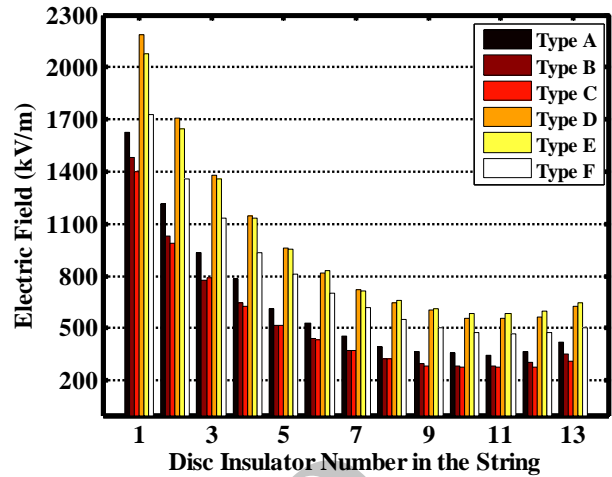

(a)

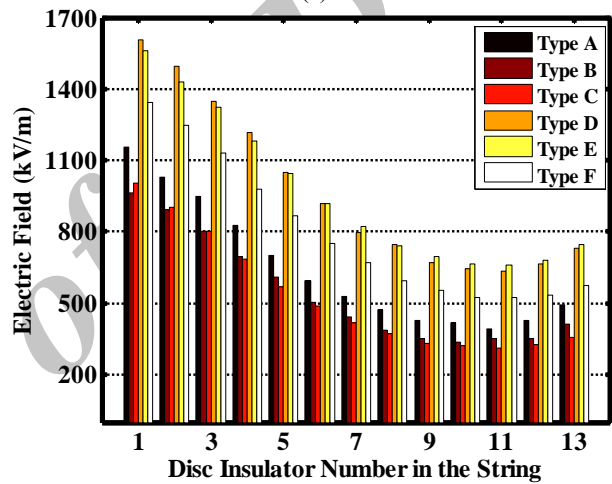

(b)

Fig. 10 Local maximums of electric field along axis of different insulator strings (a) without corona ring (b) with corona ring

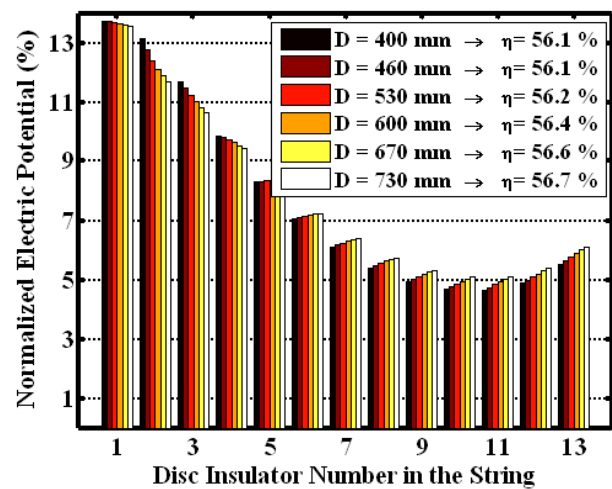

Fig. 11 Normalized electric potential distribution and efficiency for different values of the ring diameter (D)

Increasing these two parameters of corona ring reduce maximum voltage drop and maximum electric field across the insulator string and thus increase the efficiency of the insulator string.

4.5 Effects of Number of Units in the Insulator String

In order to study the effects of number of units on potential and electric field distribution and efficiency of an insulator string, strings consisting of type-A insulator units, were simulated for various number of insulator units ($n = 13, 14, 15, 16$) and results of electric potential and electric field were presented in Figs. 17 and 18, respectively. It is obvious from Fig. 17 that, increasing the number of insulators in the string reduces the maximum voltage drop along insulator units slightly; but owing to the increasing of n (number of units), efficiency of the string would fall due to Eq. (2). Also

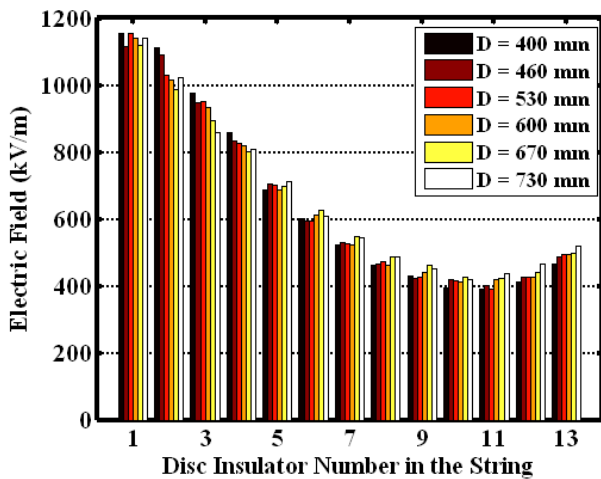

Fig. 12 Local maximums of electric field along axis of insulator string, for different values of the ring diameter (D)

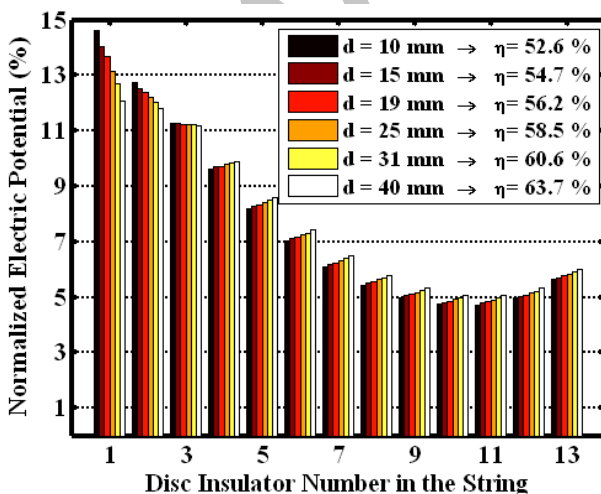

Fig. 13 Normalized electric potential distribution and efficiency for different values of diameter of the ring tube (d)

from Fig. 18 it is deduced that, increasing the number of units in the string has a slight effect on maximum electric field over bottom unit, which has the maximum stress, and reduces maximum electric field over top unit.

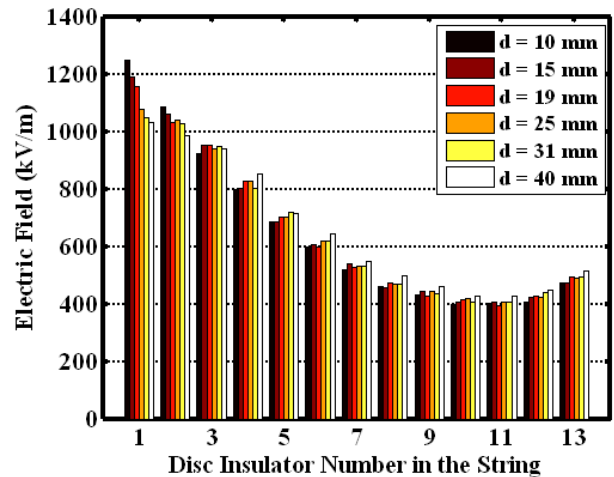

Fig. 14 Local maximums of electric field along axis of insulator string, for different values of diameter of the ring tube (d)

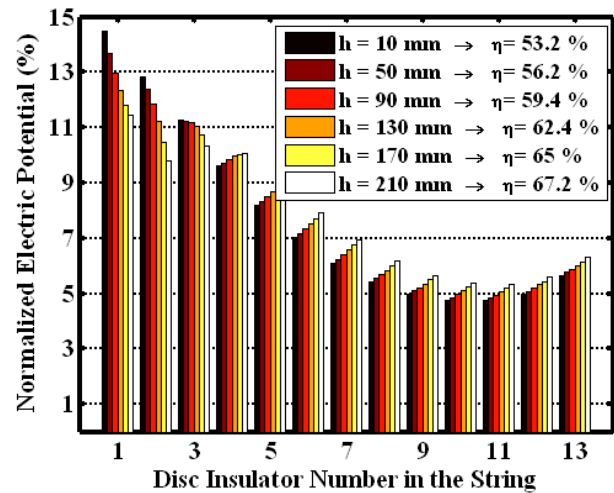

Fig. 15 Normalized electric potential distribution and efficiency for different values of vertical position of the ring along the insulator string (h)

5 Conclusions and Discussion

An attempt was done to understand the effect of disc insulator type and corona ring on the voltage and electric field distribution of 230-kV insulator strings. 3-D simulations were carried out using software based on FEM and the effects of nonsymmetrical components such as tower and conductor is taken into account.

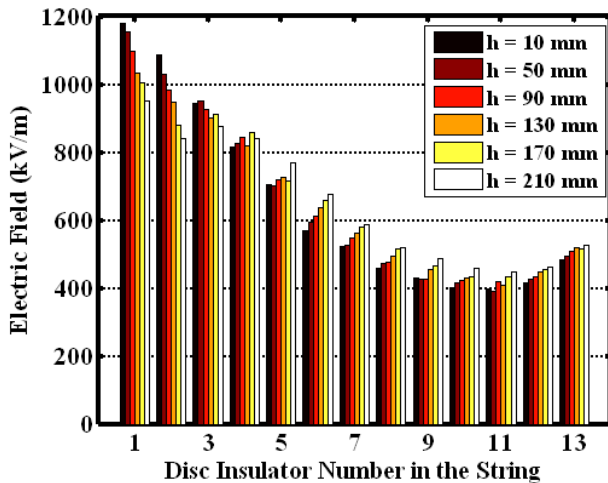

Fig. 16 Local maximums of electric field along axis of insulator string, for different values of vertical position of the ring along the insulator string (h)

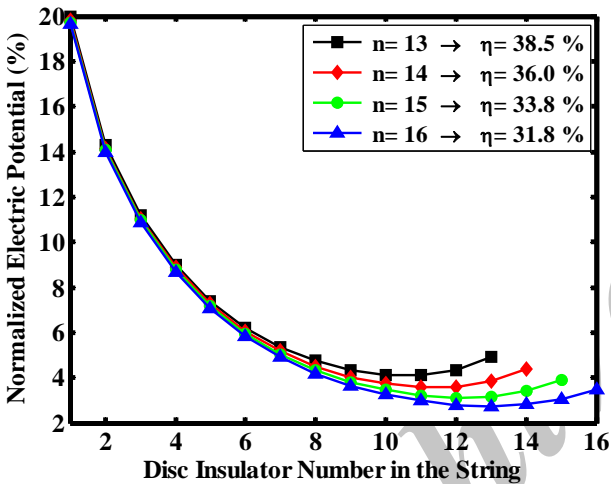

Fig. 17 Effects of number of units on normalized electric potential distribution and efficiency of a string without corona ring and consisting units of type-A

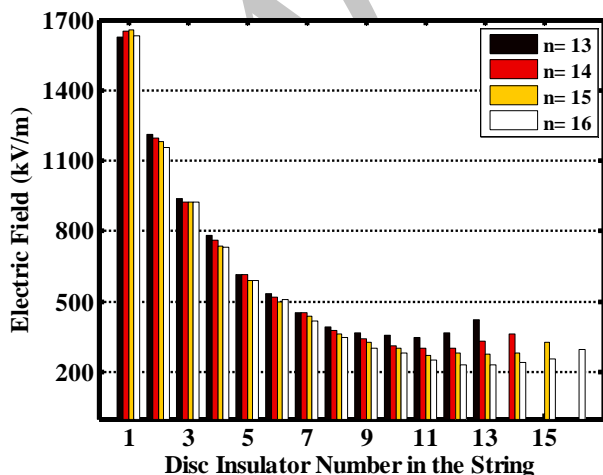

Fig. 18 Local maximums of electric field along axis of insulator string with different number of units of type-A

Calculations of electric field and voltage distributions are useful in identification of vulnerable areas of insulator units where damage and consequent breakdown may occur. From the results presented it is found that one of the most critical areas of electric field stress is triple junction (pin-cement, cement-porcelain/glass) of the bottom disc insulator unit.

According to the results, distribution of voltage and electric field over insulator strings without corona ring and the degree of improvement of voltage distribution using corona ring depends on insulator material and profile, as well as the corona ring configuration parameters. Also tower existence and conductor length can change potential and electric field distributions extremely. Hence for each particular type of insulator, corona ring parameters should be optimized to give the maximum value of string efficiency. Furthermore, it is deduced that the diameter of the corona ring (D) has a slight effect on maximum voltage and electric field across the insulator string, but increasing the diameter of the ring tube (d) and/or vertical position of the ring along the insulator (h) can improve voltage and electric field distribution of the insulator string and increase its efficiency.

All of insulators simulated in this work are common in power system; hence it is believed that the results can be very useful for the manufacturers and utilities.

Acknowledgement

The authors gratefully acknowledge Iran Insulator Co. and Pars Maghareh Co. for presenting the technical parameters of disc insulators.

References

- [1] Sima W., Yang Q., Sun C. and Guo F., "Potential and Electric-Field Calculation along an Ice-Covered Composite Insulator with Finite-Element Method", *IEE Proceedings of Generation, Transmission and Distribution*, Vol. 153, No. 3, pp. 343-349, May 2006.
- [2] Wang B. and Peng ZR., "A Finite Element Method for the Calculation of the Voltage Distribution along the 500 kV Line Insulators", *Insulators and Surge Arresters*, No.1, pp.13-15, 2003.
- [3] Kontargyri V.T., Gonos I.F., Stathopoulos I.A. and Michaelides A.M., "Measurement and verification of the voltage distribution on high-voltage insulators", *Proceedings of the 12th Biennial IEEE Conference on Electromagnetic Field Computation (CEFC 2006)*, Maimi, FL, April, pp. 326, 2006.
- [4] Al-Dhalaan S. M. and Elhribawy M. A., "Simulation of voltage distribution calculation methods over a string of suspension insulators", *IEEE PES Transmission and Distribution Conf. and Exposition*, Vol. 3, pp. 909-914, 2003.

- [5] Izgi E., Inan A. and Ay S., "The analysis and simulation of voltage distribution over string insulators using Matlab/Simulink", *Electric Power Components and Systems*, Vol. 36, No. 2, pp. 109-123, 2008.
- [6] M. G. Mohammadi, *High Voltage Technology*, 1985.
- [7] McAllister W., "Electric fields and electrical insulation", *IEEE Transactions on Dielectrics and Electrical Insulation*, Vol. 9, No. 5, pp. 672-696, 2002.
- [8] Wei H., Fan Y., Jingang W., Hao Y., Minyou C. and Degui Y., "Inverse application of charge simulation method in detecting faulty ceramic insulators and processing influence from tower", *IEEE Transactions on Magnetics*, Vol. 42, No. 4, pp. 723-726, 2006.
- [9] Morales N., Asenj E. and Valdenegro A., "Field solution in polluted insulators with non-symmetric boundary conditions", *IEEE Transactions on Dielectrics and Electrical Insulation*, Vol. 8, No. 2, pp. 168-172, 2001.
- [10] Zhao T. and Comber M. G., "Calculation of electric field and potential distribution along nonceramic insulators considering the effects of conductors and transmission towers", *IEEE Transactions on Power Delivery*, Vol. 15, No. 1, pp. 313-318, 2000.
- [11] Faisal Sh. M., "Simulation of Electric Field Distribution on Ceramic Insulator Using Finite Element Method", *European Journal of Scientific Research*, Vol. 52, No. 1, pp. 52-60, 2011.
- [12] Ashouri M., Mirzaie M. and Gholami A., "Calculation of Voltage Distribution along Porcelain Suspension Insulators Based on Finite Element Method", *Electric Power Components and Systems*, Vol. 38, pp. 820-831, 2010.
- [13] Reddy B. S., Sultan N. A., Monika P. M., Pooja B., Salma O. and Ravishankar K. V., "Simulation of potential and electric field for high voltage ceramic disc insulators", *International Conference on Industrial and Information Systems (ICIIS) 2010*, Indian Institute of Science, Bangalore, India, pp. 526-531, 2010.
- [14] Ya Dong F., Xishan W. and Fi Yu Z., "Simulation of Electric Field Distribution of Composite Insulator", *Proceedings of the 2005 XIVth International Symposium on High Voltage Engineering, Tsinghua University, Beijing, China, August 25-29, 2005*.
- [15] He J., Hu J., Gu Sh., Zhang B. and Zeng R., "Analysis and Improvement of Potential Distribution of 1000-kV Ultra-High-Voltage Metal-Oxide Arrester", *IEEE Transactions on Power Delivery*, Vol. 24, No. 3, pp. 1225-1233, 2009.



Ebrahim Akbari was born in Amol, Iran in 1984. He received the A.Sc. degree in electronics from Shiraz university of technology, Shiraz, Iran, in 2007, B.Sc. degree in electrical power engineering from Birjand University, Birjand, Iran in 2009 and M.Sc. degree in electrical power engineering from Babol University of Technology, Babol, Iran, in 2012. His research interests include High Voltage, Finite Element Method, Artificial Intelligence and Power System Operation.



Mohammad Mirzaie was born in Ghaem-Shahr, Iran in 1975. Obtained B.Sc and M.Sc Degrees in Electrical Engineering from University of Shahid Chamran, Ahvaz, Iran and Iran University of Science and Technology, Tehran, Iran in 1997 and 2000 respectively and PhD Degree in Electrical Engineering from the Iran University of Science and Technology in 2007. He worked as an Assistant Professor in the electrical and computer engineering department of Babol University of technology from 2007. His research interests include life management of high voltage equipments, high voltage engineering, intelligence networks for internal faults assessment in equipment and studying of insulation systems in transformers, cables, generators, breakers, insulators, electrical motors.



Abolfazl Rahimnejad received the B.Sc. and M.Sc. degree in electrical engineering both from Babol University of Technology, Babol, Iran, in 2009 and 2012, respectively. His research interests are electric field and magnetic field analysis, high-voltage engineering and also power quality in power systems.



Mohammad Bagher Asadpoor received the BSc degree in electrical engineering from Semnan University, Semnan, Iran, in 2009 and M.Sc. degree in electrical engineering from Babol University of Technology, Babol, Iran. His research interests are electric field and magnetic field analysis and high-voltage engineering.