

# Application of Grey Relational Analysis for Optimizing Weld Bead Geometry Parameters of Pulsed Current Micro Plasma Arc Welded AISI 304L Stainless Steel Sheets

**K. S. Prasad\* & Ch. S. Rao**

Department of Mechanical Engineering,  
ANITS, Visakhapatnam, India

E-mail: kspanits@gmail.com, csr\_au@yahoo.co.in

\*Corresponding author

**D. Nageswara Rao**

Centurion University of Technology & Management, Odisha, India

E-mail: vc@cutm.ac.in

**Received: 9 February 2012, Revised: 7 December 2012, Accepted: 18 December 2012**

**Abstract:** Pulsed Current Micro Plasma Arc Welding (PCMPAW) is one of the most widely used welding processes in sheet metal manufacturing industry. In any fusion arc welding process, the weld bead geometry plays an important role in determining the mechanical properties of the weld, which helps to improve the weld quality. Moreover, the geometry of weld bead involves several simultaneous quality characteristics, such as front width, back width, front height and back height, which must closely be monitored, controlled and optimized. This paper presents the optimization of the PCMPAW process by using the grey relational analysis considering the aforementioned quality characteristics, which are of maximum front width and back width, also minimum front height and back height. In relation to this, experiments were performed under different welding conditions such as peak current, back current, pulse rate and pulse width using AISI 304L stainless steel sheets of 0.25mm thickness using Response Surface Method (RSM) based on Central Composite Design (CCD) experimental design. It was observed that optimal welding parameters were determined by the grey relational grade from the grey relational analysis and they were also verified through confirmation experiments.

**Keywords:** ANOVA, AISI 304L Stainless Steel, Grey Relational Analysis, Micro Plasma Arc Welding, Pulsed Current, Weld Bead Geometry

**Reference:** Prasad, K. S., Rao, Ch. S., and Rao, D. N., "Application of Grey Relational Analysis for Optimizing Weld Bead Geometry Parameters of Pulsed Current Micro Plasma Arc Welded AISI 304L Stainless Steel Sheets", Int J of Advanced Design and Manufacturing Technology, Vol. 6/No. 1, 2013, pp. 79-86.

**Biographical notes:** **K. Siva Prasad** is an Assistant Professor in the Department of Mechanical Engineering, Anil Neerukonda Institute of Technology & Sciences, Visakhapatnam, India. **C. Srinivasa Rao** is an Associate Professor in the Department of Mechanical Engineering, Andhra University, Visakhapatnam, India. He received his PhD from Andhra University in 2004. **D. Nagesawara Rao** worked as a professor in Andhra University, Visakhapatnam, India for 30 years and presently he is working as Vice Chancellor, Centurion University of Technology & Management, Odisha, India.

## 1 INTRODUCTION

Plasma welding process was introduced to the welding industry in 1964 as a method of bringing better control to the arc welding process in lower current ranges [1]. Today, plasma retains the original advantages it brought to the industry by providing an advanced level of control and accuracy to produce high quality welds in both miniature and precision applications and to provide long electrode life for high production requirements at all levels of amperage. Plasma welding is equally suited to manual and automatic applications. It is used in a variety of joining operations ranging from welding of miniature components to seam welding to high volume production welding and many others.

Pulsed current MPAW involves cycling the welding current at selected regular frequency. The maximum current is selected to give adequate penetration and bead contour, while the minimum is set at a level sufficient to maintain a stable arc [2], [3]. This permits arc energy to be used effectively to fuse a spot of controlled dimensions in a short time producing the weld as a series of overlapping nuggets. By contrast, in constant current welding, the heat required to melt the base material is supplied only during the peak current pulses allowing the heat to dissipate into the base material leading to narrower Heat Affected Zone (HAZ). The advantages include improved bead contours, greater tolerance to heat sink variations, lower heat input requirements, reduced residual stresses and distortion, refinement of fusion zone microstructure and reduced width of HAZ.

There are four independent parameters that influence the process are namely, peak current, back current, pulse and pulse width. Saurav Datta et al. [4] adopted Taguchi approach followed by Grey relational analysis to solve multi response optimization problem using input parameters voltage, traverse speed, stick out, wire feed rate and creed feed, where output parameters were found to be weld penetration, weld width, weld reinforcement and depth of HAZ. Ugur Esmel et al. [5] investigated multi-response optimization of TIG welding process for an optimal parametric combination to yield favorable bead geometry of weld joints using Grey relational analysis and Taguchi method.

Y. F. Hsiao et al. [6] studied the optimal parameters process of plasma arc welding by the Taguchi method with Grey relational analysis. Torch stand-off, welding current, welding speed, and plasma gas flow rate (Argon) were chosen as input variables, where welding groove root penetration, welding groove width, front-side undercut were measured as output parameters. Hakan Aydin et al. [7] studied optimization of friction stir welding process for an optimal parametric combination to yield favorable tensile strength and

elongation using the Taguchi based Grey relational analysis.

The objective of the present paper is to achieve the optimal values of the welding process parameters in pulsed current MPAW process and to obtain sound weld bead geometry. Grey relational analysis approach is used to solve this multi-response optimization problem.

**Table 1** Chemical composition of AISI 304L stainless steel sheets (weight %)

C	Si	Mn	P	S
0.021	0.35	1.27	0.030	0.001
Cr	Ni	Mo	Ti	N
18.10	8.02	--	--	0.053

**Table 2** Important factors and their levels

Levels		1	2	3	4	5	
	Input Factor	Units	-2	-1	0	+1	+2
A	Peak Current	Amps	6	6.5	7	7.5	8
B	Back Current	Amps	3	3.5	4	4.5	5
C	Pulse rate	Pulses /Sec	20	30	40	50	60
D	Pulse width	%	30	40	50	60	70

**Table 3** Welding conditions

Power source	Secheron Micro Plasma Arc Machine (Model: PLASMAFIX 50E)
Polarity	DCEN
Mode of operation	Pulse mode
Electrode	2% thoriated tungsten electrode
Electrode Diameter	1mm
Plasma gas	Argon & Hydrogen
Plasma gas flow rate	6 Liters/min
Shielding gas	Argon
Shielding gas flow rate	0.4 Liters/min
Purging gas	Argon
Purging gas flow rate	0.4 Liters.min
Copper Nozzle diameter	1mm
Nozzle to plate distance	1mm
Welding speed	260 mm/min
Torch Position	Vertical
Operation type	Automatic

## 2 EXPERIMENTAL PROCEDURE

AISI 304L stainless steel sheets of 100 x 150 x 0.25 mm are welded autogenously with square butt joint without edge preparation. The chemical composition of AISI 304L stainless steel sheet procured from Salem Steel Plant, India is shown in Table 1. High purity argon gas (99.99%) is used as a shielding gas and a

trailing gas right after welding to prevent absorption of oxygen and nitrogen from the atmosphere. From the literature four important factors of pulsed current MPAW as presented in Table 2 are chosen for the purpose of this research.

The welding has been carried out under the welding conditions presented in Table 3. Trail experiments are carried out using 0.25 mm thickness AISI 304L

stainless steel sheets to find out the feasible working limits of pulsed current MPAW process parameters. Experiments are conducted using Response Surface Method (RSM) based four factors, five levels, rotatable Central Composite Design (CCD) matrix and the details of which are presented in Table 4. The method of designing such matrix is dealt elsewhere [8, 9].

**Table 4** Design matrix and experimental results

Serial No	Peak Current (Amperes)	Back current (Amperes)	Pulse rate (Pulses/Second)	Pulse width (%)	Front Width (mm)	Back Width (mm)	Front Height (mm)	Back Height (mm)
1	6.5	3.5	30	40	1.448	1.374	0.0609	0.0498
2	7.5	3.5	30	40	1.592	1.522	0.0588	0.0458
3	6.5	4.5	30	40	1.383	1.324	0.0630	0.0490
4	7.5	4.5	30	40	1.504	1.442	0.0569	0.0439
5	6.5	3.5	50	40	1.454	1.401	0.0581	0.0453
6	7.5	3.5	50	40	1.487	1.418	0.0595	0.0466
7	6.5	4.5	50	40	1.469	1.378	0.0599	0.0468
8	7.5	4.5	50	40	1.462	1.402	0.0578	0.0448
9	6.5	3.5	30	60	1.529	1.451	0.0599	0.0470
10	7.5	3.5	30	60	1.591	1.508	0.0571	0.0441
11	6.5	4.5	30	60	1.520	1.447	0.0572	0.0441
12	7.5	4.5	30	60	1.562	1.506	0.0552	0.0423
13	6.5	3.5	50	60	1.442	1.372	0.0605	0.0474
14	7.5	3.5	50	60	1.384	1.306	0.0590	0.0456
15	6.5	4.5	50	60	1.506	1.430	0.0600	0.0470
16	7.5	4.5	50	60	1.420	1.356	0.0584	0.0464
17	6	4	40	50	1.521	1.451	0.0598	0.0468
18	8	4	40	50	1.580	1.514	0.0569	0.0439
19	7	3	40	50	1.452	1.380	0.0575	0.0445
20	7	5	40	50	1.427	1.358	0.0564	0.0434
21	7	4	20	50	1.596	1.527	0.0582	0.0453
22	7	4	60	50	1.466	1.397	0.0564	0.0434
23	7	4	40	30	1.400	1.337	0.0636	0.0516
24	7	4	40	70	1.461	1.384	0.0602	0.0472
25	7	4	40	50	1.531	1.462	0.0606	0.0476
26	7	4	40	50	1.581	1.512	0.0597	0.0467
27	7	4	40	50	1.523	1.452	0.0607	0.0477
28	7	4	40	50	1.519	1.450	0.0606	0.0476
29	7	4	40	50	1.504	1.432	0.0607	0.0477
30	7	4	40	50	1.501	1.433	0.0576	0.0446
31	7	4	40	50	1.401	1.332	0.0597	0.0456

### 3 MEASUREMENT OF WELD BEAD GEOMETRY

Three metallurgical samples were cut from each joint, with the first sample being located at 25mm behind the trailing edge of the crater at the end of the weld there by mounting them using Bakelite. Sample preparation and mounting was done as per ASTM E 3-1 standard. The transverse face of the samples were surface grounded using 120 grit size belt with the help of belt grinder, polished using grade 1/0 (245 mesh size), grade 2/0 (425 mesh size) and grade 3/0 (515 mesh size) sand paper.

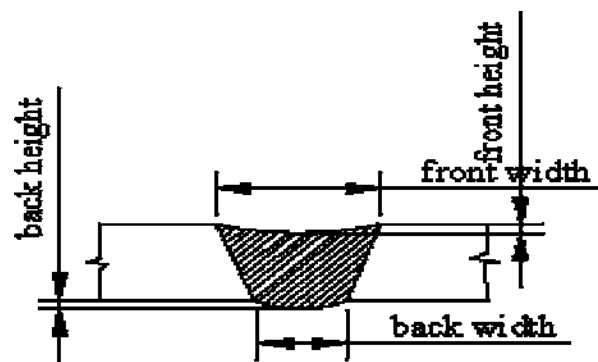

**Fig. 1** Typical weld bead geometry

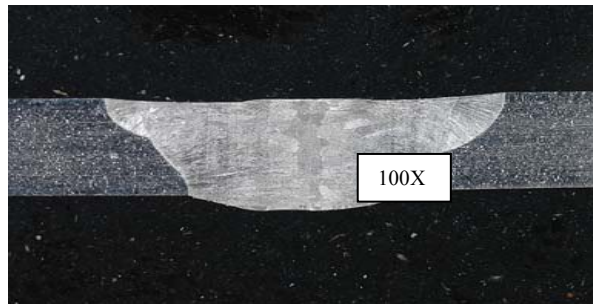

Fig. 2 Macrographs of weld bead

The specimens were further polished by using aluminum oxide initially, and by utilizing diamond paste and velvet cloth in a polishing machine. The polished specimens were macro-etched by using 10% Oxalic acid solution to reveal the geometry of the weld bead (Fig. 1) [10]. Several critical parameters, such as front width, back width, front height and back height of the weld bead geometry (Fig. 2) were measured [10]. The weld bead geometry was measured using Metallurgical Microscope (Make: Dewinter Technologie, Model No. DMI-CROWN-II) at 100X magnification.

#### 4 GREY RELATIONAL ANALYSIS

The grey system theory was proposed by Deng [11]. The grey means the primitive data with poor, incomplete and uncertain information in the grey systematic theory. The incomplete relation of information in this data is called the grey relation. Grey relational analysis can effectively be recommended as a method for optimizing the complicated inter-relationships among multiple performance characteristics [12]. Through the grey relational analysis, a grey relational grade is obtained to evaluate the multiple performance characteristics. As a result, optimization of the complicated multiple performance characteristics can be converted into the optimization of a single grey relational grade.

In grey relational analysis, experimental data i.e. measured features of quality characteristics are first normalized ranging from zero to one. The process is known as grey relational generation. Next, based on normalized experimental data, grey relational coefficient is calculated to represent the correlation between the desired and actual experimental data. Then overall grey relational grade is determined by averaging the grey relational coefficient corresponding to selected responses.

The overall performance characteristic of the multiple response process depends on the calculated grey relational grade. This approach converts a multiple

response process optimization problem into a single response optimization situation where the objective function is overall grey relational grade. The optimal parametric combination is then evaluated which would result into highest grey relational grade. The steps followed in the optimization process are:

- (i) Normalizing the experimental responses for all the trials. The normalized expression (1) corresponding to smaller-the-better criteria is:

$$y_i(k) = \frac{\max x_i(K) - x_i(K)}{\max x_i(K) - \min x_i(K)} \quad (1)$$

where,  $k=1$  to  $n$ ;  $i=1$  to  $31$ ,  $n$  is the performance characteristic and  $i$  is the trial number. The normalized expression corresponding to larger-the-better criteria is:

$$y_i(k) = \frac{x_i(K) - \min x_i(K)}{\max x_i(K) - \min x_i(K)} \quad (2)$$

where  $y_i(k)$  is the value after grey relational generation,  $\min x_i(k)$  is the smallest value of  $x_i(k)$  for  $k^{\text{th}}$  response and  $\max x_i(k)$  is the largest value of  $x_i(k)$  for the  $k^{\text{th}}$  response.

- (ii) Performing the Grey relational generating and to calculate the Grey relational coefficient ( $\gamma$ ).

$$\gamma(y_0(K), y_i(K)) = \frac{\Delta_{\min} + \zeta \cdot \Delta_{\max}}{\Delta_{0i}(K) + \zeta \cdot \Delta_{\max}} \quad (3)$$

where  $\Delta_{0i}(K) = |y_0(K) - y_i(K)|$  is the absolute value of the difference between  $y_0(K)$  and  $y_i(K)$ ,  $\Delta_{\min} = \min \min \Delta_{0i}(K)$ ,  $\Delta_{\max} = \max \max \Delta_{0i}(K)$ ,  $\zeta \in (0, 1)$  = distinguished coefficient.

- (iii) Calculating the Grey relational grade by averaging the Grey relational coefficient.

$$\xi_i = \frac{1}{n} \sum_{k=1}^n \gamma_i(K) \quad (4)$$

- (iv) Performing statistical analysis of variance (ANOVA) for the input parameters with the Grey relational grade and to find which parameter significantly affects the process.
- (v) Selecting the optimal levels of process parameters.
- (vi) Conduct confirmation experiment and verify the optimal process parameters setting.

**Table 5** Grey relational generation and  $\Delta_{0i}$  of each performance characteristics

Serial No	Normalized			Deviation Sequence ( $\Delta_{0i}$ )				
	Front Width	Front Width	Back Width	Front Height	Back Height	Back Width	Front Height	Back Height
1	0.305164	0.307692	0.321429	0.193548	0.694836	0.692308	0.678571	0.806452
2	0.981221	0.977376	0.571429	0.623656	0.018779	0.022624	0.428571	0.376344
3	0	0.081448	0.071429	0.27957	1	0.918552	0.928571	0.72043
4	0.568075	0.615385	0.797619	0.827957	0.431925	0.384615	0.202381	0.172043
5	0.333333	0.429864	0.654762	0.677419	0.666667	0.570136	0.345238	0.322581
6	0.488263	0.506787	0.488095	0.537634	0.511737	0.493213	0.511905	0.462366
7	0.403756	0.325792	0.440476	0.516129	0.596244	0.674208	0.559524	0.483871
8	0.370892	0.434389	0.690476	0.731183	0.629108	0.565611	0.309524	0.268817
9	0.685446	0.656109	0.440476	0.494624	0.314554	0.343891	0.559524	0.505376
10	0.976526	0.914027	0.77381	0.806452	0.023474	0.085973	0.22619	0.193548
11	0.643192	0.638009	0.761905	0.806452	0.356808	0.361991	0.238095	0.193548
12	0.840376	0.904977	1	1	0.159624	0.095023	0	0
13	0.276995	0.298643	0.369048	0.451613	0.723005	0.701357	0.630952	0.548387
14	0.004695	0	0.547619	0.645161	0.995305	1	0.452381	0.354839
15	0.577465	0.561086	0.428571	0.494624	0.422535	0.438914	0.571429	0.505376
16	0.173709	0.226244	0.619048	0.55914	0.826291	0.773756	0.380952	0.44086
17	0.647887	0.656109	0.452381	0.516129	0.352113	0.343891	0.547619	0.483871
18	0.924883	0.941176	0.797619	0.827957	0.075117	0.058824	0.202381	0.172043
19	0.323944	0.334842	0.72619	0.763441	0.676056	0.665158	0.27381	0.236559
20	0.206573	0.235294	0.857143	0.88172	0.793427	0.764706	0.142857	0.11828
21	1	1	0.642857	0.677419	0	0	0.357143	0.322581
22	0.389671	0.411765	0.857143	0.88172	0.610329	0.588235	0.142857	0.11828
23	0.079812	0.140271	0	0	0.920188	0.859729	1	1
24	0.366197	0.352941	0.404762	0.473118	0.633803	0.647059	0.595238	0.526882
25	0.694836	0.705882	0.357143	0.430108	0.305164	0.294118	0.642857	0.569892
26	0.929577	0.932127	0.464286	0.526882	0.070423	0.067873	0.535714	0.473118
27	0.657277	0.660633	0.345238	0.419355	0.342723	0.339367	0.654762	0.580645
28	0.638498	0.651584	0.357143	0.430108	0.361502	0.348416	0.642857	0.569892
29	0.568075	0.570136	0.345238	0.419355	0.431925	0.429864	0.654762	0.580645
30	0.553991	0.574661	0.714286	0.752688	0.446009	0.425339	0.285714	0.247312
31	0.084507	0.117647	0.464286	0.645161	0.915493	0.882353	0.535714	0.354839

**5 ANALYSIS OF WELD DATA**

The specific targets in the present paper are maximum front width and back width, minimum front height and back height. Therefore, for data preprocessing in the grey relational analysis process, front height and back height were taken as the “lower is better” and front width and back width were taken as “higher is better”, respectively. Initially, using Equation’s (1) and (2), experimental data have been normalized to obtain Grey relational generation. The normalized data and  $\Delta_{0i}$  for

each of the responses of bead geometry have been furnished in Table 5. The distinguishing coefficient  $\zeta$  is substituted into Equation 3 to produce the grey relational coefficient. If all the process parameters are of equal weighting, then  $\zeta$  becomes 0.5. The gray relational coefficients and grade values for each experiment of the design matrix were calculated by applying the Equation’s (3) and (4) (Table 6).

**Table 6** Grey relational coefficient and Grey relational grade of each performance characteristics ( $\zeta = 0.5$ )

Serial No	Grey Relation Coefficient				Grey Relation Grade
	Front Width	Back Width	Front Height	Back Height	
1	0.418468	0.419355	0.424242	0.382716	0.411195
2	0.963801	0.95671	0.538462	0.570552	0.757381
3	0.333333	0.352472	0.35	0.409692	0.361374
4	0.536524	0.565217	0.711864	0.744	0.639401
5	0.428571	0.46723	0.591549	0.607843	0.523799
6	0.4942	0.503417	0.494118	0.519553	0.502822
7	0.456103	0.425819	0.47191	0.508197	0.465507
8	0.442827	0.469214	0.617647	0.65035	0.54501
9	0.613833	0.592493	0.47191	0.497326	0.543891
10	0.955157	0.853282	0.688525	0.72093	0.804473
11	0.583562	0.580052	0.677419	0.72093	0.640491
12	0.758007	0.840304	1	1	0.899578
13	0.408829	0.416196	0.442105	0.476923	0.436013
14	0.33438	0.333333	0.525	0.584906	0.444405
15	0.541985	0.53253	0.466667	0.497326	0.509627
16	0.376991	0.39254	0.567568	0.531429	0.467132
17	0.586777	0.592493	0.477273	0.508197	0.541185
18	0.869388	0.894737	0.711864	0.744	0.804997
19	0.42515	0.429126	0.646154	0.678832	0.544815
20	0.38657	0.395349	0.777778	0.808696	0.592098
21	1	1	0.583333	0.607843	0.797794
22	0.450317	0.459459	0.777778	0.808696	0.624063
23	0.352066	0.36772	0.333333	0.333333	0.346613
24	0.440994	0.435897	0.456522	0.486911	0.455081
25	0.620991	0.62963	0.4375	0.467337	0.538864
26	0.876543	0.880478	0.482759	0.513812	0.688398
27	0.593315	0.595687	0.43299	0.462687	0.52117
28	0.580381	0.589333	0.4375	0.467337	0.518638
29	0.536524	0.537713	0.43299	0.462687	0.492478
30	0.528536	0.540342	0.636364	0.669065	0.593577
31	0.353234	0.361702	0.482759	0.584906	0.44565

**Table 7** Response table (mean) for overall grey relational grade

Level/ Factor	A	B	C	D
	(Peak Current)	(Back Current)	(Pulse rate)	(pulse width)
1	0.5412	0.5448	0.7978	0.3466
2	0.4865	0.5530	0.6322	0.5258
3	0.5576	0.5875	0.5468	0.6354
4	0.6325	0.5660	0.4868	0.5932
5	0.8050	0.5921	0.6241	0.4551
Delta	0.3185	0.0473	0.3110	0.2888
Rank	1	4	2	3

To find out the optimum process parameters and their effects on selected output parameters, the mean of the Grey relational grade for each level of the welding parameter is needed. Table 7 indicates mean for overall grey relational grade. The larger the value of the Grey relational grade, the better is the multi response characteristics. Therefore, the optimal level of the welding parameters is the level with the greatest grey relational grade value. The optimal welding performance for higher front width, back width and lower front height, back height was obtained for the following combination: peak current 8 Amperes, back current 5 Amperes, pulse rate 20 pulses/second and pulse width 50%.

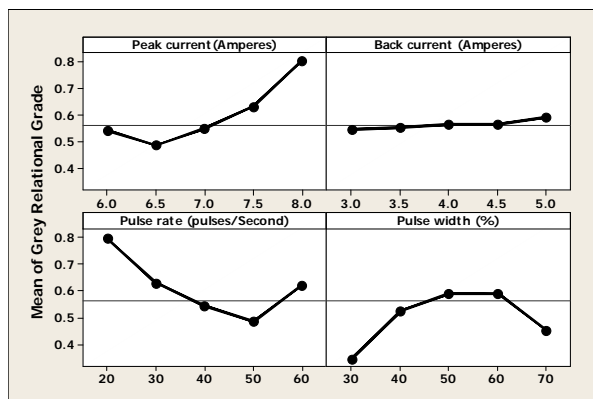

Fig. 3 Effect of welding parameters on grey relational grade

Figure 3 indicates the effect of welding parameters on the multi-performance characteristics and the response graph of each level of the welding parameters for the performance. The higher values in Figure 3 give the desired quality characteristic. Also, the maximum and minimum values of the grey relational grade show the importance of individual parameter in PCPAW process. Hence, the order of importance of the welding parameters is peak current, pulse rate, pulse width, and back current.

## 6 CONFIRMATION EXPERIMENTS

After evaluating the optimal parameter settings, the next step is to predict and verify the enhancement of quality characteristics using the optimal parametric combination. Table 8 shows the comparison of the predicted bead geometry parameters with that of actual using the optimal MPAW welding conditions. It is found that there is a good agreement between the actual and predicted results have been observed (improvement in the overall Grey relational grade).

It is found that utilization of the optimal welding parameter combination enhances the grey relational grade from 0.411195 to 1, i.e. grey relational grade has improved by 41.1195%.

Table 8 Results of confirmation test

	Initial	Optimal Testing parameters	
		Predicted	Experimental
Combination	A-1,B-1,C-1,D-1	A2,B2,C-2,D0	A2,B2,C-2,D0
Front Width	1.448		1.712
Back width	1.374		1.658
Front Height	0.0609		0.052
Back Height	0.0498		0.024
Grey Relational Grade	0.411195	1.14086	1

## 7 CONCLUSION

- The optimization of multi-performance characteristics of Pulsed Current Plasma Arc Welding process using Grey Rational Analysis based on RSM based CCD design has been investigated in the present paper.
- The optimal weld bead geometry is obtained at a peak current of 8 Amperes, back current of 5 Amperes, pulse rate of 20 pulses/second and pulse width of 50% from Grey Relational Analysis.
- It is observed from Grey Relational Analysis that the order of importance of the welding parameters is peak current, pulse rate, pulse width and back current.
- The optimum result helps the operator in obtaining desired performance measure which saves the operator's time, cost and helps in increasing the productivity.

## ACKNOWLEDGMENTS

The authors would like to thank Shri, R. Gopla Krishnan, Director, M/s Metallic Bellows (I) Pvt Ltd, Chennai, India for his support to carry out experimental works.

## REFERENCES

- [1] Balasubramanian, M., Jayabalan, V., and Balasubramanian, V., "Effect of process parameters of pulsed current tungsten inert gas welding on weld bead geometry of titanium welds", Acta Metall. Sin. (Engl. Lett.), Vol. 23, No. 4, 2010, pp. 312-320.

- [2] Balasubramanian, B., Jayabalan, V., and Balasubramanian, V., "Optimizing the Pulsed Current Gas Tungsten Arc Welding Parameters", *J Mater Sci Technol*, Vol. 22, No. 6, 2006, pp. 821-825.
- [3] Madusudhana Reddy, G., Gokhale, A. A., and Prasad Rao K., "Weld microstructure refinement in a 1441 grade aluminium-lithium alloy", *Journal of Material Science*, Vol.32, No.15, 1997, pp. 4117-4126.
- [4] Saurav, D., Asish, B., and Pradip Kumar, P., "Grey-based taguchi method for optimization of bead geometry in submerged arc bead –on-plate welding", *Int J Adv Manuf Technol*, Vol. 39, No. 11-12, 2008, pp. 1136-1143.
- [5] Ugur, E., Melih, B., Yugut Kazan, C., and Sueda, O., "Optimization of weld bead geometry in TIG welding process using Grey relation analysis and taguchi method", *Journal of Material and Technology*, Vol. 43, No. 3, 2009, pp. 143-149.
- [6] Hsiao, Y. F., Tarn, Y. S., and Huang, W. J., "Optimization of plasma arc welding parameters by using the taguchi method with the grey relational analysis", *Materials and Manufacturing Processes*, Vol. 23, No. 1, 2008, pp. 51-58.
- [7] Hakan, A., Bayram, A., Ugur, E., Kazancoglu, Y., and Onur, G., "Application of Grey relational analysis and taguchi method for the parametric optimization of friction stir welding process", *Materials and Technology*, Vol. 44, No. 4, 2010, pp. 205-211.
- [8] Montgomery, D. C., "Design and analysis of experiments", 3rd Edition, New York: John Wiley & Sons, 1991, pp. 291-295.
- [9] Box, G. E. P., Hunter, W. H., and Hunter, J. S., "Statistics for experiments", New York: John Wiley & Sons, 1978, pp. 112-115.
- [10] Siva Prasad, K., Srinivasa Rao, Ch., and Nageswara Rao, D., "Prediction of Weld Bead Geometry in Pulsed Current Micro Plasma Arc Welding of SS304L Stainless Steel Sheets", *International Transaction Journal of Engineering, Management & Applied Sciences & Technologies*, Vol. 2, No. 3, 2011, pp. 325-336.
- [11] Deng, J., "Control problems of grey systems", *Systems and control Letters*, Vol. 1, 1982, pp. 288-294.
- [12] Tsao, C. C., "Grey-Taguchi method to optimize the milling parameters of aluminum alloy", *Int J Adv Manuf Technol*, Vol. 40, 2009, pp. 41-48.