

# Engineering Design of Guidance System of 6R Tele-robot based on DTMF

**M. H. Korayem\***

Robotic Research Laboratory, Center of Excellence in Experimental Solid Mechanics and Dynamics, School of Mechanical Engineering, Iran University of Science and Technology, Tehran, Iran

E-mail: hkorayem@iust.ac.ir

\*Corresponding author

**S. R. Nekoo & A. H. Korayem**

Robotic Research Laboratory, Center of Excellence in Experimental Solid Mechanics and Dynamics, School of Mechanical Engineering, Iran University of Science and Technology, Tehran, Iran

E-mail: rafee@iust.ac.ir, hkorayem@iust.ac.ir

**Received: 26 April 2014, Revised: 14 May 2014, Accepted: 3 June 2014**

**Abstract:** In this article, the advantages of navigation based on dual tone multiple frequencies (DTMF) technique through telecommunication lines is studied. First, the calculations of direct and inverse kinematics of the manipulator in computer are transferred to the PIC microprocessors center. Next, each PIC is required to control and automate the relevant link separately. The main purpose of this work is making it possible to control the robot via a telephone line without a modem. In order to apply this idea, computer has analyzed the data received from the operator and inserts the necessary instructions through the serial port using AVR microcontroller in the embedded hardware at the phone line and sending them to the robot hardware. Then the robot performed the processes as a closed loop design and provided the necessary feedback for the computer. Real-time control, low volume of software and hardware computations and the possibility of using the phone lines with low and medium bandwidth in addition to ADSL lines simultaneously, are the special features of this method. In the proposed method, control data and the corresponding feedbacks are transmitted as the remote closed loop control, which can be combined in the developing stages with other control methods such as neural networks which results the maximum productivity. At the end of this work, examination of the time delay of tele-controller system and experimenting according to the ISO9283 standard, specific to the accuracy of the robot, is carried out.

**Keywords:** Dual Tone Multiple Frequencies, ISO9283, Teleportation, Telerobot, Time Delay

**Reference:** Korayem, M., H., Nekoo, S. R., and Korayem, A., H., "Engineering Design of Guidance System of 6R Tele-robot based on DTMF", Int J of Advanced Design and Manufacturing Technology, Vol. 7/ No. 3, 2014, pp. 57-63.

**Biographical notes:** **M. Habibnejad Korayem** received his BSc and MSc in Mech. Eng. from Amir kabir Univ. of Tech. in 1985 and 1987, respectively. He obtained his PhD in Mech. Eng. from the Univ. of Wollongong, Australia, in 1994. He is a Professor in Mech. Eng. at Iran Univ. of Science and Tech. **S. Rafee Nekoo** received his BSc in Mech. Eng. from the Azad Univ., south branch in 2007 and MSc in Mech. Eng. from Iran Univ. of Science and Tech. in 2010. He is presently PhD student in Mech. Eng. in Iran Univ. of Science and Tech. **A. Habibnejad Korayem** is presently MSc student in Mech. Eng. in Iran Univ. of Science and Tech.

## 1 INTRODUCTION

Recently, the control and navigation of systems via internet were increased [1]; however the time delay is a challenging issue in these systems. The usages of remote control systems via internet in different areas such as biomechanics, automation, vehicles and military industries are highlighting the importance of this technique. The commencement of using teleportation system was frequency modulation in network, where this method developed fast via internet. For the first time, a six degree-of-freedom robot arm was controlled using internet [1]. In a similar work, a robot arm was navigated via network, considering the data transferring protocol [2], where the computer was used as master and slave. The tele-garden robot for using in the field [3], a PUMA arm for painting [4] and tele-robot Max [5] are some of the examples in this area.

Karad et al. proposed the navigation of a mobile robot via teleportation based on DTMF [6]. Keber et al., presented the control of a PUMA arm with internet network and simulated the problem with arm details [7]. Zhenyuan et al., introduced a combination of different techniques based on image reconstruction for predicting the direction of motion to improve the system performance [8], [9]. Tele-echo robot (TER), which had two master and slave parts, was presented in ref. [10]. In the system, a Matrox Meteor board with a FFMPEG library changed any image, 640\*480 Pixel, to an 8 bit code for transferring. In the mentioned research, most of the calculation was done by computer and generally they had massive hardware. The real time working of these works are depended on the network speed; on the other hand many of them were designed for local network. These reasons are the main motivation of the present research to propose an algorithm based on DTMF for controlling 6R robot via teleportation.

## 2 STRUCTURE OF A TELE-ROBOT

6R articulated robot is a manipulator with six degree of freedom, including six DC motors with independent gearbox for each. Like other tele-robots, it consists of master and slave elements. The main devices include a computer in the master, a main digital board which six driver boards for motors in the slave and two tele-control boards, one in the master and one in the slave. In fact the structure of the controller is divided into two parts: controller and tele-controller. The control unit consists of different sections. The main controller is on the motherboard where it receives the input commands from tele-board and sends back the feedback to

computer, which is angular position of links. 6R robot and the control unit are presented in Fig. 1.

First joint revolves around vertical axis. Second, third and the fourth joints have horizontal revolution axis and make vertical movements for the arm. The fifth and sixth joints make pitch and roll rotations. The configuration of the robot is shown in Fig. 2.

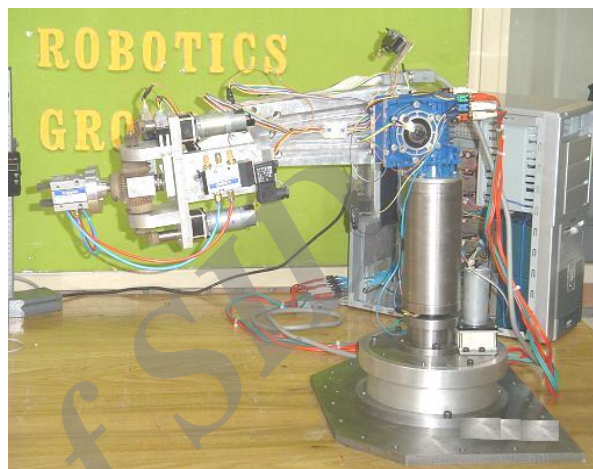

Fig. 1 6R robot and its control unit

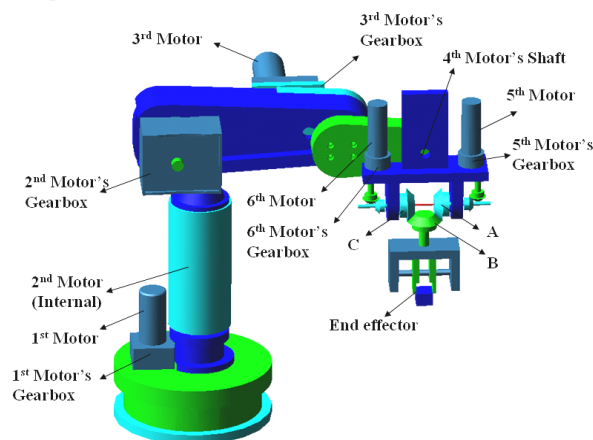

Fig. 2 6R robot mechanical configuration

In this work, control of the robot based on transferring data via telephone line is expressed. In this method, the modulations are done in dual tone form for sending and receiving data. Moreover the angle variations of the links are sent from the slave to the master in real time. This modulation has the following advantages:

- High precision in transferring digital data due to using two high and low frequencies for each four bit data simultaneously as presented in Table 1.
- Reduction in hardware and software implementation.

- Being dynamic for having different length of frames for transferring data.
- Capability of using all lines of telephone systems.
- No need to modems in master and slaves.

In the proposed idea, both main processors are independent and capable of sending and receiving different frames in phone lines. The data transferring speed is increased due to omitting local filters.

**Table 1** The values of frequencies in high and low modulation

ACTIVE INPUT	OUTPUT FREQUENCY (Hz)		%ERROR
	SPECIFIED	ACTUAL	
L1	697	699.1	+0.30
L2	770	766.2	-0.49
L3	852	847.4	-0.54
L4	941	948.0	+0.74
H1	1209	1215.9	+0.57
H2	1336	1331.7	-0.32
H3	1477	1471.9	-0.35
H4	1633	1645.0	+0.73

### 3 MODEL OF THE ROBOT

In order to obtain the equations of direct kinematics the Denavit-Hartenberg parameters of the arm are needed to be presented (Fig. 3). The parameters of the arms are presented in Table 2.

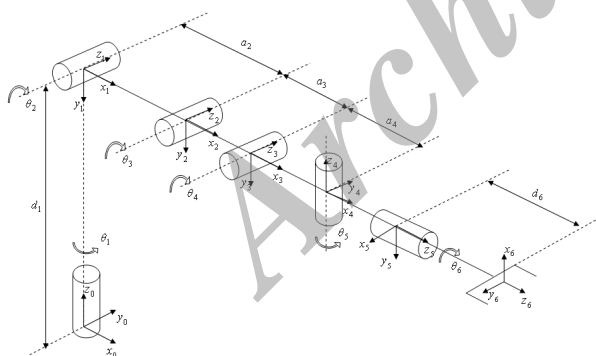

**Fig. 3** Schematic of 6R robot manipulator

Using Denavit-Hartenberg parameters and transformation matrices, as:

$$T = T_1^0 T_2^1 T_3^2 T_4^3 T_5^4 T_6^5, \tag{1}$$

$$T = \begin{bmatrix} n_x & o_x & a_x & p_x \\ n_y & o_y & a_y & p_y \\ n_z & o_z & a_z & p_z \\ 0 & 0 & 0 & 1 \end{bmatrix}, \tag{2}$$

Where  $n, o, a$  vectors are elements of rotation matrix and  $p$  vector is end-effector position of the robot. The details of the matrix is presented as:

$$n_x = -C_6 S_1 S_5 + C_1 (C_{234} C_5 C_6 - S_{234} S_6), \tag{3}$$

$$n_y = C_6 (C_{234} C_5 S_1 + C_1 S_5) - S_1 S_{234} S_6, \tag{4}$$

$$n_z = -C_5 C_6 S_{234} - C_{234} S_6, \tag{5}$$

$$o_x = S_1 S_5 S_6 - C_1 (C_6 S_{234} + C_{234} + C_{234} C_5 S_6), \tag{6}$$

$$o_y = C_6 S_1 S_{234} - (C_{234} C_5 S_1 + C_1 S_5) S_6, \tag{7}$$

$$o_z = -C_{234} C_6 + C_5 S_{234} S_6, \tag{8}$$

$$a_x = -C_5 S_1 - C_1 C_{234} S_5, \tag{9}$$

$$a_y = C_1 C_5 - C_{234} S_1 S_5, \tag{10}$$

$$a_z = S_{234} S_5, \tag{11}$$

$$p_x = -C_5 S_1 d_6 + C_1 \begin{pmatrix} a_1 + C_2 a_2 + \\ C_{23} a_3 + C_{234} (a_4 - S_5 d_6) \end{pmatrix}, \tag{12}$$

$$p_y = C_1 C_5 d_6 + S_1 \begin{pmatrix} a_1 + C_2 a_2 + \\ C_{23} a_3 + C_{234} (a_4 - S_5 d_6) \end{pmatrix}, \tag{13}$$

$$p_z = -S_2 a_2 - S_{23} a_3 + d_1 + S_{234} (-a_4 + S_5 d_6). \tag{14}$$

**Table 2** Denavit-Hartenberg parameters of the arm

Joint number (i)	$a_i$	$d_i$	$a_i(^{\circ})$	$\theta_i$	motion
1	0	$d_1=438$ mm	-90	$\theta_1$	Link1
2	$a_2=251.5$ mm	0	0	$\theta_2$	Link2
3	$a_3=125$ mm	0	0	$\theta_3$	Link3
4	$a_4=92$ mm	0	90	$\theta_4$	Link4(Yaw)
5	0	0	-90	$\theta_5$	(Pitch)
6	0	$d_6=152.8$ mm	0	$\theta_6$	(Roll)

The inverse kinematics for manipulators with less than three degree of freedom could be found analytically, but for complicated arms, the inverse kinematics equations are not easy to find. The inverse kinematics equations of this manipulator are presented as follows:

$$\theta_1 = \tan^{-1} \left[ \frac{p_y - d_6 a_y}{p_x - d_6 a_x} \right], \tag{15}$$

$$\theta'_1 = \theta_1 + \pi, \tag{16}$$

$$\theta_5 = \tan^{-1} \left[ \frac{\pm d_6 \left[ 1 - (a_y C_1 - a_x S_1)^2 \right]^{\frac{1}{2}}}{p_y C_1 - p_x S_1} \right], \quad (17)$$

$$\theta_2 + \theta_3 + \theta_4 = \theta_{234} = \tan^{-1} \left( \frac{-a_z}{a_x C_1 + a_y S_1} \right), \quad (18)$$

$$\theta'_{234} = \theta_{234} + \pi \text{ for } \theta_5 < 0, \quad (19)$$

$$\theta_6 = \tan^{-1} \left[ \frac{o_x S_1 - o_y C_1}{n_y C_1 - n_x S_1} \right] \text{ for } \theta_5 > 0, \quad (20)$$

$$\theta'_6 = \theta_6 + \pi \text{ for } \theta_5 < 0, \quad (21)$$

$$\theta_2 = \tan^{-1} \left[ \frac{\pm \left[ 1 - \left( \frac{w}{q} \right)^2 \right]^{\frac{1}{2}}}{\frac{w}{q}} \right] + \tan^{-1} \left[ \frac{u}{t} \right], \quad (22)$$

$$\theta_3 = \tan^{-1} \left[ \frac{u - a_2 S_2}{t - a_2 C_2} \right] - \theta_2, \quad (23)$$

$$\theta_4 = \theta_{234} - \theta_2 - \theta_3, \quad (24)$$

$$t = C_1 p_x + S_1 p_y + d_6 S_5 C_{234} - a_4 C_{234}, \quad (25)$$

$$u = -p_z + d_1 - a_4 S_{234} + d_6 S_5 S_{234}, \quad (26)$$

$$w = \frac{-a_3^2 + t^2 + u^2 + a_2^2}{2a_2}, \quad (27)$$

$$q = (t^2 + u^2)^{1/2}. \quad (28)$$

#### 4 HARDWARE STRUCTURE

The control unit of this tele-robot has three main parts:

##### a) Motherboard:

The motherboard is designed for providing and distributing motors power. Additionally it should provide the communication between the control section and the robot arm. The drivers of the motors are also set on the motherboard as presented on Fig. 4.

Based on the program, the output data of kinematics equations in computer are sent to the motherboard via RS232 port after changing the voltage level to TTL with Max232. This data is sent to the microprocessors PIC 16F876A which have the control algorithm of the method. The responsibility of the microprocessors also includes the motors synchronization, feedback computation and calculation of PWM (Fig. 5).

Commands are sent to transistors LMD18200 where they provide the motors power. Optical counters at the top of the shafts of motors supply the feedbacks.

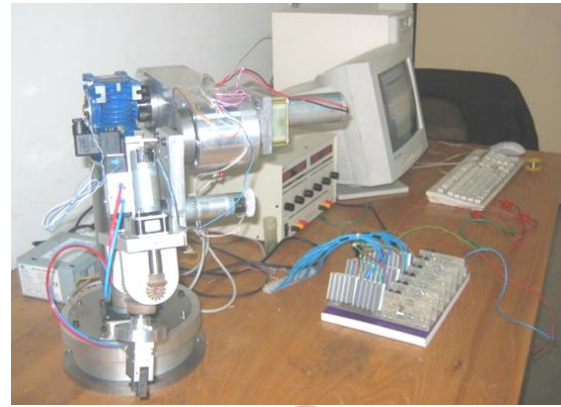

Fig. 4 Motherboard of 6R robot manipulator

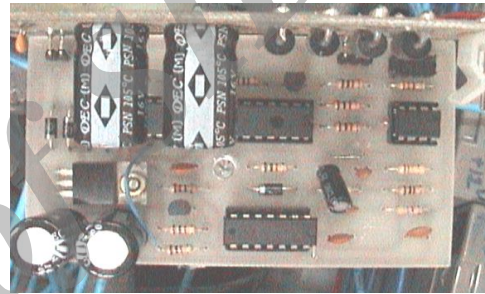

Fig. 5 PIC 16F876A board

##### b) The hardware of tele-controller:

The AVR microcontroller is chosen as the main processor of this part due to having suitable computation speed to prevent time delay in transferring and operating. ATmega64 processor is the link between the master and slave, which transfers the data of kinematics equations. Figure 6 shows the tele-controller diagram.

MT8888CE is a chip, which has the responsibility of sending, and receiving data, consists of filters and digital coding functions. In its filtering part, switching techniques for high and low frequencies and digital coding for generating signals are used. The outer devices of chip are small in size where it is simply a difference operational amplifier and a crystal clock. Low power consumption, capability of variation of internal gain and guard time are the advantages of this device [8]. HIN232 has RS232 output port and changes the voltage level to TTL. CH1817D plays the buffer role in the board and prevents interference of sending and receiving signals. ATmega64 is the processor of tele-controller board and it is the link between different modes of MT8888CE with input controls and output to RS232. Framing in software programming is also its duty. This board has the pad for entering a phone

number and a LCD for presenting the necessary data (Fig. 7).

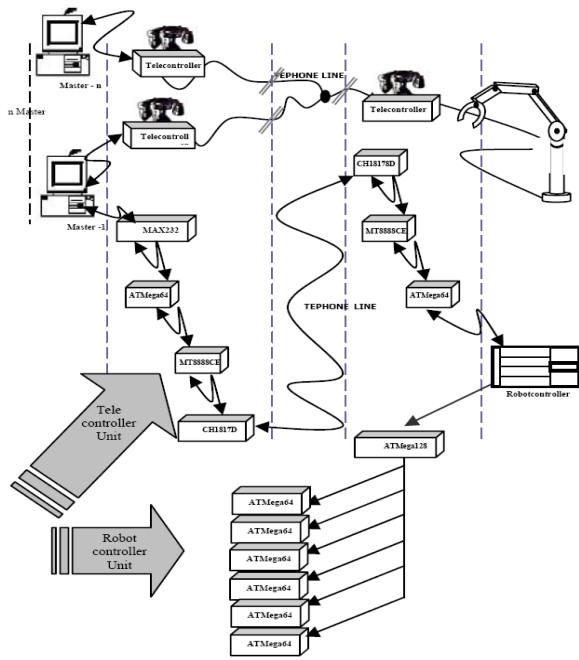

Fig. 6 Tele-controller diagrams

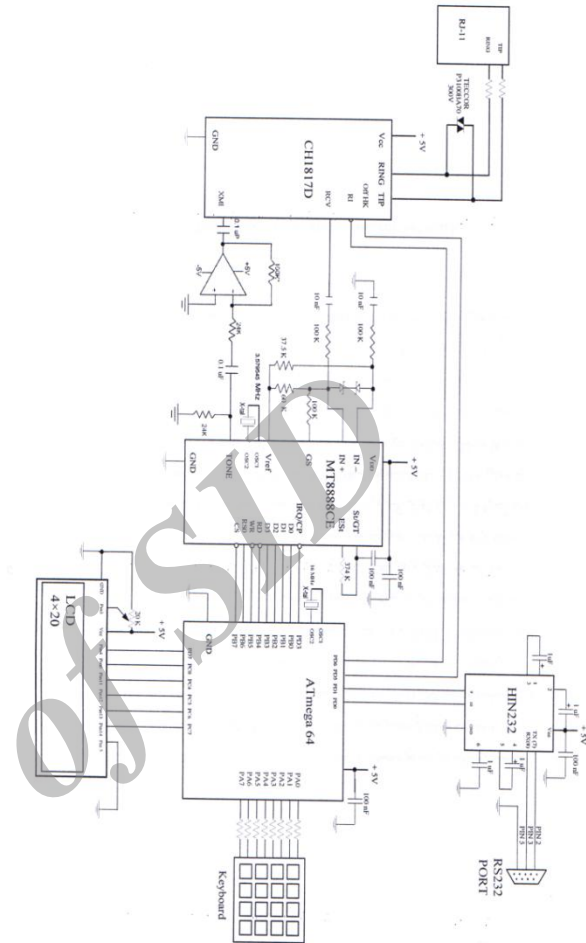

Fig. 7 Tele-controller hardware circuits

## 5 SOFTWARE STRUCTURE

### a) Software of control unit:

The control unit software has three sections. The first section is the program in PC, where this program is written in Delphi programming language including the computation of the kinematics equations. The second section is the program in motherboard, which receives the data of PC via serial port and applies them to motor drivers. The third section is the program of the control board where the PWM percentages of motors are computed in this part. The correction of mechanical errors are considered in this program, too.

### b) Software of tele-controller unit:

The interface of this program has the following responsibilities:

- Defining the mode of master or slave.
- The waiting mode of slave for receiving master's commands.
- Automatic dialing using the tele-controller board in master mode.
- Displaying different states to operator.
- Identification of slave by master.

In order to detect the master by slave, a four-bit random data is sent to master and the response is another bit-match for the code which slave receives. The correct sending and receiving of this action confirms the true connection. The framing of the data after detection is sent as a hex code to declare the commencement of the process. Then the first four-bits present the number of motors and its direction and the value of links angles (Fig. 8).

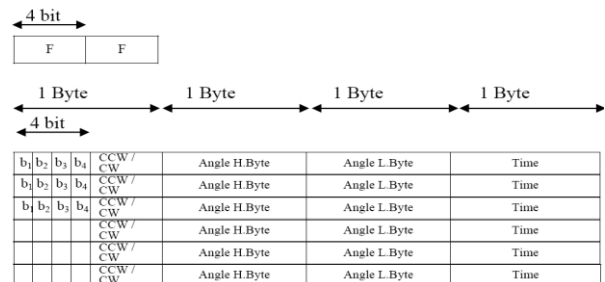

Fig. 8 Framing structure



## 6 EXPERIMENTS

In order to test a robot, different parameters must be taken into consideration: the accuracy of the assembly, manufacturing tolerances, external forces, friction and the robot controller. The following tests are based on ISO9283 standard.

**Table 3** Results for 10 experiments

No.	$x_i$	$y_i$	$z_i$
1	477.7	269.1	399.26
2	477.85	269.2	398.03
3	480.7	271.8	391.81
4	477.05	269.9	399.4
5	478.3	275.2	398.05
6	479.75	276.2	395.21
7	479.8	274.9	394.9
8	478.2	279.3	398.74
9	478.8	281.5	397.17
10	477.95	281	397.16

**Table 4** Average position of motion in axis

$\bar{x}$	$\bar{y}$	$\bar{z}$
478.61	274.81	396.97

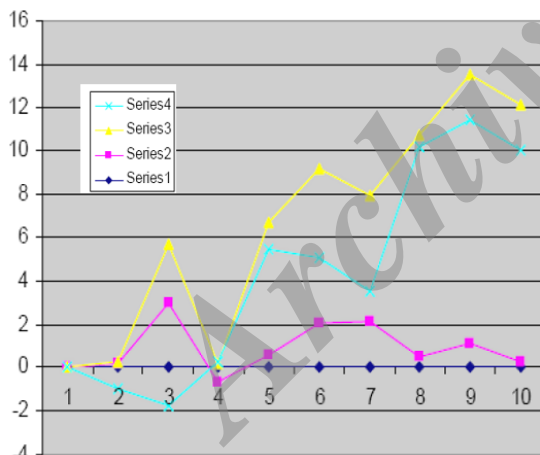

**Fig. 9** Result of position error

### a) Positioning accuracy test:

In this test, a set point is defined for the arm where this point is checked  $n$  times as target. The position of the desired point is defined in the  $X, Y, Z$  axis.  $X_p, Y_p, Z_p$  are the experimental measurement of displacement.

$$AP_p = \sqrt{(\bar{x} - x_c)^2 + (\bar{y} - y_c)^2 + (\bar{z} - z_c)^2}$$

$$AP_x = \bar{x} - x_c$$

$$AP_y = \bar{y} - y_c$$

$$AP_z = \bar{z} - z_c$$
(29)

The errors are calculated based on Eq. (29), where  $AP_p$  is the position error and  $AP_x, AP_y, AP_z$  are the errors in  $X, Y, Z$  axes. The results of the tests are shown in Table 3 and the average of the motion in Table 4. The test result is presented in Fig. 9.

### b) Position repeatability test

This test was run for a path and the result is presented in Fig. 10.

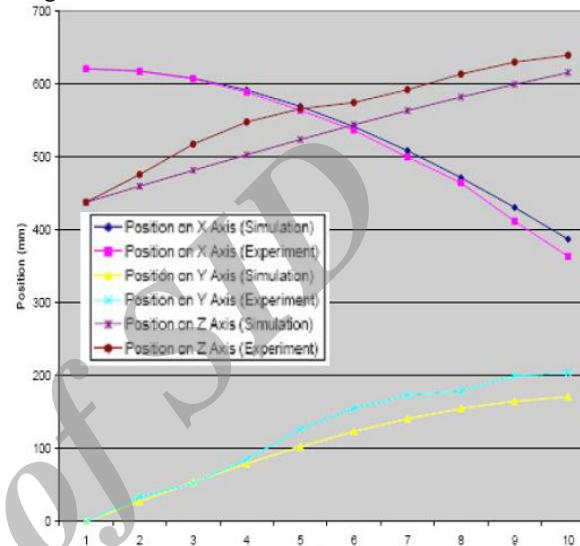

**Fig. 10** Result of repeatability test

### c) Delay test

In order to run this test, two different phone lines were used. This set of test examined the tele-controller board. The result of the delay test is presented in Table 5.

**Table 5** Delay test result

Repetition	Send Time of Master	Receive Time in Slave	Delay Time
1	10:45':12"	10:45':13"	00:00':1"
2	11:05':06"	11:05':07"	00:00':1"
3	11:15':22"	11:15':24"	00:00':2"
4	17:24':10"	17:24':12"	00:00':2"
5	12:02':08"	12:02':09"	00:00':1"
6	14:35':23"	14:35':24"	00:00':1"
7	17:24':14"	17:24':15"	00:00':1"
8	12:02':08"	12:02':09"	00:00':1"
9	18:13':23"	18:13':24"	00:00':1"
10	18:16':23"	18:16':24"	00:00':1"

---

## 7 CONCLUSION

---

In this article, a tele-controller for navigation of 6R manipulator was proposed based on DTMF technique. Reduction in hardware devices, compatibility with phone lines and improving the communication speed are the advantages of this method. This method also does not need modem and internet and as a result, it works without local filters. The result of this method was satisfactory based on ISO standard.

---

## REFERENCES

---

- [1] Goldberg, K., Mascha, M., Gentner, S., Rothenberg, N., Sutter, C., and Wrigley, J., "Desktop teleportation via the World Wide Web", Proc. IEEE Int. Conference on Robotics and Automation, 1995, pp. 654-659.
- [2] Lu, S. J., Chen, B. M., KO, C. C., Kee, Sh. T., and Poon, M., "Web-based Robot for Remote Experiments", The Fourth International Conference on Control and Automation (ICCA'03), Montreal, Canada, June 2003.
- [3] Goldberg, K., Santarromana, J., Bekey, G., Gentner, S., Morris, R., Wiegley, J., and Berger, E., "The Telegarden", Proceedings of ACM SIGGRAPH, 1995, pp. 135-1140.
- [4] Stein, M., "Painting on the World Wide Web: The Puma Paint Project", IEEEERSJ, International Conference on Intelligent Robots and Systems, 1998, pp. 37-43.
- [5] Ferworn, A., Roque, R., and Vecchia, I., "MAX Wireless teleoperation via the World Wide: Web", Proc. IASTED Conf. on Robotics and Applications, Santa Barbara, 28-30 Oct. 1999, pp. 158-162.
- [6] [www.isprs.org](http://www.isprs.org)
- [7] [http://people.engr.ncsu.edu/dbkaber/telepresence/research\\_projects/interface\\_development/telerobot\\_interface.htm](http://people.engr.ncsu.edu/dbkaber/telepresence/research_projects/interface_development/telerobot_interface.htm)
- [8] Deng, Zh., Jagersand, M., "Predictive display system for tele-manipulation using image-based modeling and Rendering", Intelligent. Proc. Robots and systems, IROS 2003, Vol. 2, Las Vegas, USA, 2003.
- [9] Charles, C., Nguyen, C., Zhou, Z. L., and Mosier, G. E., "Joint-space adaptive control of a redundant telerobot manipulator", Proc. 4th IEEE International Symposium on Intelligent Controls, Albany, New York, September 1989, pp. 59-65.
- [10] Vilchis, A., Troccaz, J., Cinquin, P., Masuda, K., and Pellissier, F., "A new robot architecture for tele-echography", IEEE Transaction on Robotics and Automation, Vol. 19, No. 5, Oct. 2003.
- [11] <http://www.ic-online.cn/search.php?part=sp8643a&stype=fts>

Archive 03