

# Characterization of Stress Concentration in Thin Cylindrical Shells with Rectangular Cut-out under Axial Pressure

**O. Sam Daliri**

School of Mechanical Engineering,  
College of engineering, University of Tehran, Tehran, Iran,  
E-mail: [omid\\_sam@ut.ac.ir](mailto:omid_sam@ut.ac.ir)

**M. Farahani\***

School of Mechanical Engineering, College of engineering,  
University of Tehran, Tehran, Iran,  
E-mail: [mrfarahani@ut.ac.ir](mailto:mrfarahani@ut.ac.ir)

\*Corresponding author

Received: 21 December 2016, Revised: 13 February 2017, Accepted: 27 February 2017

**Abstract:** In this paper, stress concentration in the thin cylindrical shell with rectangular cut-out subjected to uniform axial pressure was investigated using a parametric finite element model. Design of experiments techniques and statistical analysis was used to provide a model for characterizing the critical stress in these components. The influences of the geometrical parameters and their combinations were studied in detail. It was observed that the length to width ratio of the cut-out, the length and the radius to thickness ratio of the cylinder were significant parameters for describing the stress concentration around the cut-out, respectively. By increasing the length to width ratio as a main effective geometrical factor in the stress concentration, the stress around the cut-out was increased significantly. Based on the statistical analysis conducted in this study, a formula was derived which can predict the stress concentration around the cut-out of the cylinder with the accuracy more than 84% ( $R^2 = 88.7\%$ ,  $R^2_{pred} = 84.6\%$ ,  $R^2_{adj} = 86.7\%$ ).

**Keywords:** Finite element method, Statistical analysis, Stress concentration, Thin cylindrical shell, Rectangular Cut-out

**Reference:** Sam Daliri, O., Farahani, M., "Characterization of Stress Concentration in Thin Cylindrical Shells with Rectangular Cut-out under Axial Pressure", Int J of Advanced Design and Manufacturing Technology, Vol. 10/ No. 2, 2017, pp. 133–141.

**Biographical notes:** **O. Sam Daliri** is a PhD candidate in Mechanical Engineering at University of Tehran, Iran. His current research interest mainly focuses on finite element modelling, adhesive joints, nanocomposites, damage sensing. **M. Farahani** is Assistant Professor of Mechanical engineering at the University of Tehran, Iran. He received his PhD in Mechanical engineering from Amir Kabir University of Technology. He also worked as a research assistant at the technical university of Delft. His current research focuses on damage sensing and welding engineering using experimental and numerical analysis.

---

## 1 INTRODUCTION

---

Thin shells with cylinder geometry are used in marine, mechanical and aerospace structures. These engineering structures are commonly employed under the axial compressive loads and often have imperfections such as cut-out, which have significant effects on their mechanical properties. Cut-outs in thin cylindrical shell components are inevitable due to the variety of design requirements and practical issues. Moreover, the cut-outs are necessary to access to the internal parts and components of the structures. A cut-out causes high local stresses and sometimes leads to the local failure of the structures. As a result, magnitude of stress concentrations around the cut-out should be considered in the design procedure. So the determination of stress concentration factor (SCF) around the cut-out is highly required in the primary design of the perforated cylinders.

Many analytical, numerical and experimental investigations have been conducted during the past seventy years to determine the stress distributions in thin cylindrical shells with a cut-out. Many of these investigations have been related to the isotropic cylindrical shells and considered the effects of the cut-out shape on the stress concentrations [1], [2]. Many researches were conducted to evaluate SCF in engineering structures. A study was conducted to compute SCF in the circular cylindrical shell by the analytical method [3] then Aliabadi, Rooke and Cartwright have presented an improved boundary element formulation for calculating SCF in aerospace structures [4]. Theocaris and Petrou have obtained SCF in an infinite plate with a triangular cut-out [5]. They also have achieved stress and strain distribution in an infinite elastic plate boundary with a rectangular hole [5]. In 1990, Folias and Wang have presented a review of the studies on stress distribution around the cut-outs [6]. Their research resulted in a series solution for stress distribution around a circular cut-out in a plate of an arbitrary thickness. Lasko and et al have investigated the stress distribution near the multiple pores and rigid inclusion under uniaxial tensile loading by relaxation elements [7]. Singh and Paul have presented numerical result based on work-energy method for linear and geometrically nonlinear static analysis of thin isotropic plate for a rectangular plate with a circular cut-out and a circular plate with a rectangular cut-out [8]. Paik has investigated the ultimate strength characteristics of perforated steel plates under edge shear loading. Their nonlinear finite element analysis resulted to analytical formulas which can be useful for cut-out plate's strength estimation [9]. Rezaeepazhand and Jafari have evaluated stress concentration in metallic plates with special shaped cut-out [10]. They have also validated their formulation

by comparing their analytical results with those obtained using finite element (FE) method. Woo and Na have studied the effects of the cut-out orientation on stress concentration of perforated plates with various cut-outs and bluntness [11]. They have also considered not only various cut-out shapes such as Circular, triangular and square cut-outs but also different cut-out orientations. Recently, many studies have been carried out about the stress concentration on the structural behaviour of shells with different cut-outs [12-16]. Furthermore, with the recent advances in computational tools and in consideration of the difficulty in conducting experimental studies, non-dimensional [17] and statistical analysis have become the preferable tools for the condition assessment of SCF in mechanical structures [18], [19] also have been considered an effective tool in the FE method [20-23]. With this context, a better understanding of the main parameter affected on SCF in thin cylindrical shells predominantly subjected to axial compression is necessary. From the standpoint of cut-out shape, circular, triangular elliptical and rectangular cut-outs are the utmost shapes that have been studied in the plate, tube and sheet like structure [24-28].

The aim of this research is to determine the stress concentration in the isotropic thin cylindrical shell with a rectangular cut-out under axial pressure. In this paper parametric investigation of stress concentration in the thin cylindrical shell with a rectangular cut-out is conducted under axial compression. There is no theoretical relation to determine the stress concentration around the cut-out. In this work a relation for SCF is achieved in the thin cylindrical shell with a rectangular cut-out through an efficient statistical model using FE analysis. So we can reduce the magnitude of stress concentration around the cut-out by choosing the model dimensions with the right geometry parameters.

---

## 2 FINITE ELEMENT ANALYSIS

---

All Numerical evaluations using PYTHON executable codes in the ABAQUS software [29] were conducted to study the stress concentration in thin cylindrical shell with rectangular cut-out. Geometrical parameters of rectangular cut-out are depicted schematically in Fig. 1. The elastic properties of the aluminum alloys were considered in this study ( $E=70$  GPa,  $\nu=0.3$ ). The effect of cut-out position was neglected and the cut-out was positioned in the mid-length of the cylinder. Previous studies proved that the cut-out positioned at the mid-length of the cylinder was more critical [30]. Cylindrical radius ( $R$ ), cylindrical length ( $L$ ), cut-out length ( $a$ ) and width ( $b$ ) and cut-out height ( $H$ ) are presented in Fig. 1.

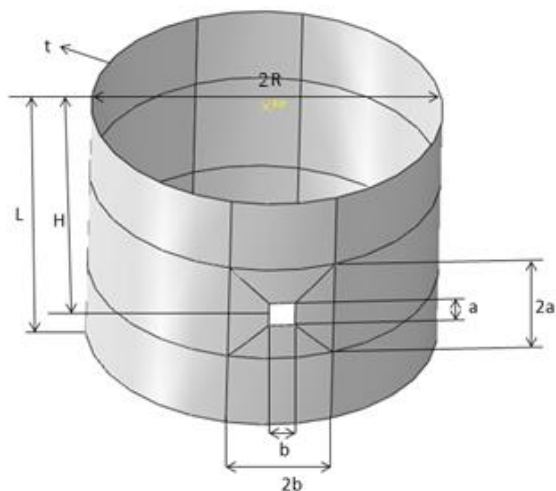

Fig. 1 Geometrical parameters of cylindrical shell with rectangular cut-out

There are two specific regions in cylinder; around and far from the cut-out. Because of high stress concentration around the cut-out, these regions are separated from each other by partitioning method. Smaller and larger meshes were considered around and far from the cut-out respectively. So the number of elements in the whole model is decreased significantly and the computation time is reduced. A parametric FE model was developed for this thin-cylindrical shell, SR8 shell elements with eight nodes was employed to generate the mesh on the cylinder. The shell element thickness is considered constant all over the cylinder. The generated mesh is shown in Fig. 2. In order to study the stress distribution around the cut-out, an axial (Path- C- 1) and a hoop path (Path- L- 1) were defined as shown in Fig. 2.

The axial compressive load was applied along the cylinder length at the reference point (RP) on the rigid top surface of the cylinder. This load is transferred uniformly to the cylinder nodes as the RP and nodes on the top surface of the cylinder were coupled in axial direction. Due to the stress concentration around the cut-out, the effect of mesh size on stress concentration in this area is studied. The  $a/n$  ratios are the size of the elements in this area in which the parameter "a" is employed for the edge length of the cut-out and "n" is a numerical constant. Different sizes of elements in this area have been generated by considering different ratios of  $a/10$ ,  $a/20$ ,  $a/30$  and  $a/40$ .

Axial, radial and von Mises stresses are compared for different sizes of the element and different paths around the cut-out. 150 mm × 150 mm and 400 mm × 400 mm cut-outs are used to investigate the stress distribution around the cut-out, as the finer mesh than  $a/20$  had no significant effect on the stress distribution around the cut-out, so in the following a ratio equal to  $a/20$  was employed [31].

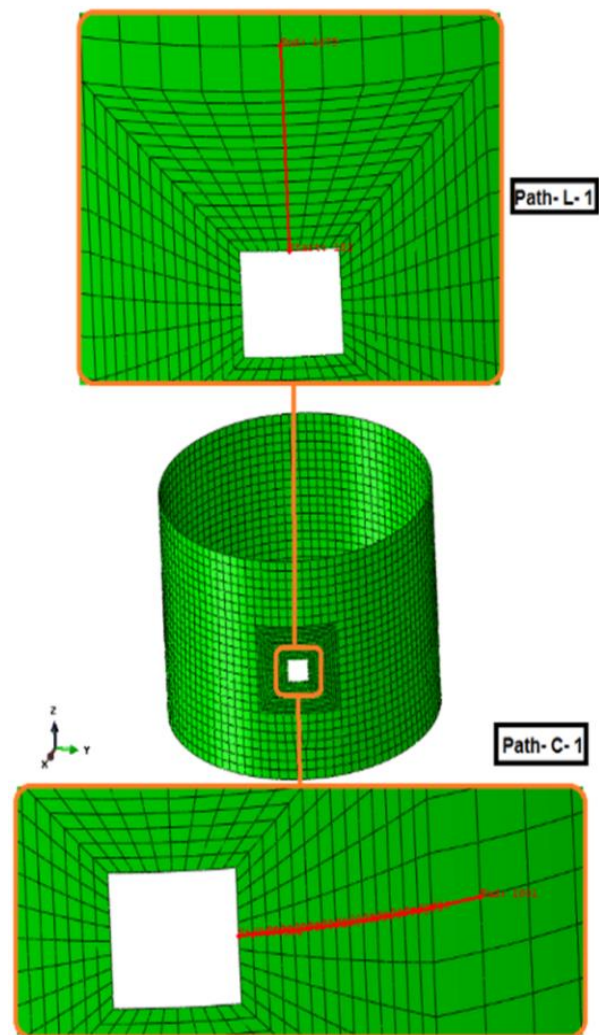

Fig. 2 FEM mesh with two circumferential (C-1) and longitudinal (L-1) paths

For example, in Fig. 3, von Mises stress distribution around the cut out for different cut out and mesh sizes are shown.

In the following the von Mises, axial and hoop stresses distribution in a thin cylindrical shell with 150 mm × 150 mm square cut-out and mesh size of  $b/20$  are shown in Fig. 4. Components of axial and hoop stresses for far from the cut-out have uniform stress distribution equal to 54.4 MPa and 0 MPa. Using the simple classical relations, the axial stress far from the cut-out could be estimated by Eq. (1).

$$\text{Cut-out } S_{cut} = \frac{F}{(2\pi R - b)t} \quad (1)$$

So for the mentioned geometry, the axial stress is obtained 53.05 MPa. However, hoop stress in far from

the cut-out is expected to be zero because there is not an additional external force in this direction. Thus von Mises stress in far from the cut-out is equal to the axial stress in the model about 53.05 MPa. Very good conformity has been observed between the numerical and analytical results. Attentive to the confirmation of the obtained stress distribution in far from the cut-out, the obtained stress distribution around the cut-out is also acceptable due to the linear elastic model employed in this study.

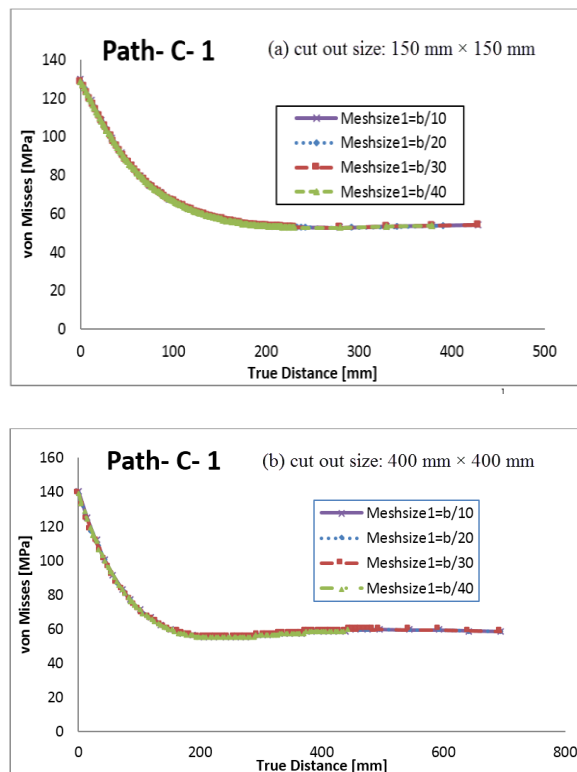

**Fig. 3** Von Mises stress distribution in the cylindrical shell in cylindrical shell for different mesh size with square cut out size (a) 150 mm x 150 mm (b) 400 mm x 400 mm

**2.1. The effect of boundary conditions on the stress distribution**

Two types of BC, simply support and clamped support, are considered in this study. In this section, the effect of BCs on von Mises stress distribution in the L-1 path is investigated for two different square cut-out size. As seen in Fig. 5-a and Fig. 5-b, the BCs at the bottom of the cylinder have no significant effect on the stress concentration values around the cut out. As a result, simply support BC is considered in the following as it is closer to the actual BC of the cylinder.

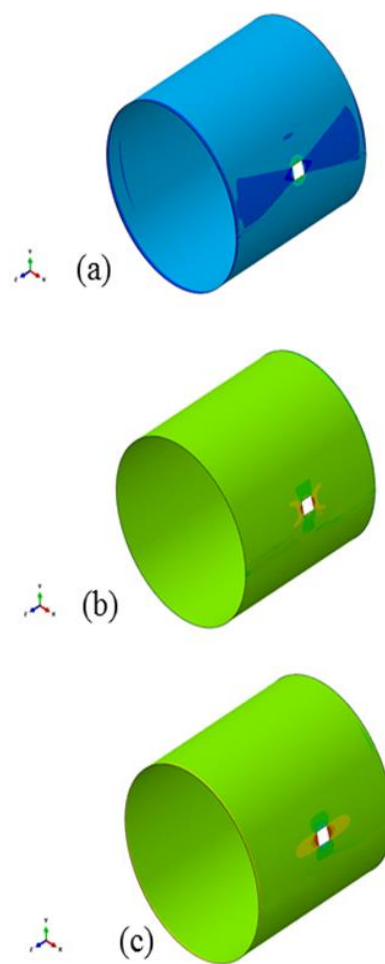
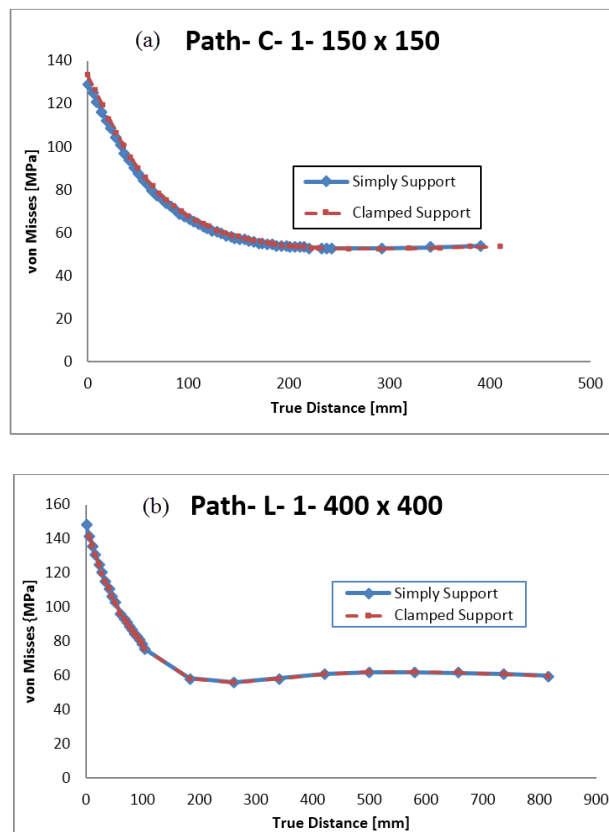

**Fig. 4** (a) Von Mises, (b) axial and (c) hoop stress distribution in thin cylindrical shell with 150 mm x 150 mm

**2.2. Stress analysis with different sizing of cut-out**

In this section for two different sizes of square cut-out, axial and hoop stresses are presented in Fig. 6 and Fig. 7. The other parameters are considered to be constant. No significant change in stress level far from the cut-outs was observed. Increasing in the cut-out size leads to a small increase in axial stress about 0.1 percent farther from the cut-out.

As can be seen from Fig. 7, the magnitude of hoop stress was changed significantly with the change of cut-out size. By increasing the sizes of cut-out from 150 to 400 mm, maximum hoop stress around the cut-out decreased by approximately 40 percent. Hoop stress far from the cut-out at sample with the larger cut-out is larger than that of the small cut-out, as illustrated in Fig. 7.



**Fig. 5** Effect of various BCs on von Mises stress distribution for different cut out size in the (a) circumferential path (b) longitudinal path

### 3 PARAMETRIC INVESTIGATION

The FE simulation shows that critical axial stress is occurring in the vertical middle edge of the cylinder. A large stress concentration was also observed at the corner of the cut-out which could be explained by the sharp edge considered in the model. As this stress is very local and according to small radius that usually are generated during the manufacturing process, so this stresses could be neglected. In this study the maximum axial stress in the middle of vertical edge of cut-out are considered as critical stress. In order to normalize the results, this stress is divided to axial stress in the full cylinder under the same load. This ratio is called SCF, which is employed in the following.

Up to now it has calculated the stress distribution around the rectangular cut-out. There are several geometric parameters of the thin cylindrical shell with rectangular cut-out that may affect the magnitude of stress concentration around the cut-out. For example, if the cut-out length follows a normal distribution, there

are two parameters: the main and standard deviation of the cut-out length. In general, there are five parameters ( $L$ ,  $b$ ,  $a$ ,  $t$  and  $R$ ) of the model. Among these parameters and interaction between them, some have significant effects on the magnitude of stress concentration around the cut-out and others have smaller effects. In this section, a study for determining the effects of parameters on the SCF around the rectangular cut-out was conducted. The obtained results can be used for reducing the magnitude of stress concentration around the cut-out by choosing thin cylindrical shell with rectangular cut-out dimensions with the right geometry parameters.

So at first, it is necessary to identify the factors independently associated with the analysis. The considered lower and upper limit of various geometric parameters is listed in Table 1. The ranges with the highest application were considered in this study.

#### 3.1 Design of experiments

In general usage, design of experiments (DOE) or experimental design is the design of true experiment under natural condition in which the variation is existent [32], [33]. Factorial designs are generated to examine interaction effects of variables. In other words, factorial designs involve the study of two or more factors or variables, where each factor is allocated to limit values or levels, and each possible factor-level variation is tested over several experimental runs [34, 35]. Full factorial designs are the simplest form of factorial designs in which all possible factor-level combinations are tested [35].

The initial estimation was conducted using thirty two tests with five parameters ( $L$ ,  $b$ ,  $a$ ,  $t$ , and  $R$ ) and two levels for each parameter to evaluate the effect of each parameter on the magnitude of stress concentration in a thin cylindrical shell with rectangular cut-out. The main effect plot and interaction plot could show how a change of factor levels could change the result of the study. Pareto chart could be used to characterize those factors with the greatest effects on the SCF.

In this chart the effects of factor were first standardized and then plotted in a decreasing order of the value of the effects. The factors that have the higher standardized effects in the Pareto chart had more effects on the experimental results. To separate factors with significant effects from those with insignificant effects, a reference line was drawn. Reference line which was employed in this study is an approach for modelling the relationship between a scalar dependent variable and one or more explanatory variables (or independent variable). Factors with effects passing the reference line are considered to the significant effects.



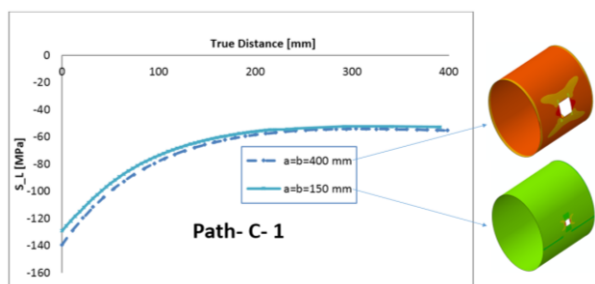

Fig. 6 Comparison of axial stress on circumferential path for two different sizes of cut-out

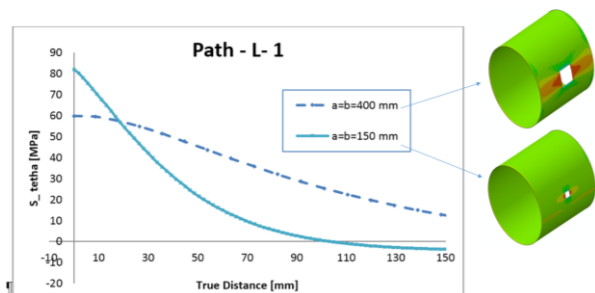

Fig. 7 Comparison of hoop stress on longitudinal path for two different sizes of cut-out

Table 1 Geometric parameter ranges for the parametric study

Parameter	Lower limit	Upper limit	Lower limit	Upper limit
R	750	200	150	500
t	150	0	400	1500
a	1.5	0	5	
b				
L				

### 3.2 Effects of geometric parameters of thin cylindrical shell on the SCF around the cut-out

Statistical analysis using analysis of variance method led to a model with the accuracy of  $R^2=72.75\%$ . In the following the impact of primitive parameters is shown in Fig. 8 to assess the effect of primitive geometric parameters on the SCF. As seen a, b and L have the significant effect on the SCF while R and t have the least one. The Pareto chart in Fig. 9 validates this issue. In order to increase the accuracy of the statistical model and decrease the number of low effective parameters, different combination of R and t, R and L, and a and b were employed to develop a more accurate model. At the first step, four different combinations of R and t (Rt, R/t, t/R and 1/Rt) were employed. By using R/t parameter and third order analysis, the accuracy of statistical model has been increased significantly. The P value for R/t in this analysis was 0.03 which confirm the effectiveness of this parameter. In the following, different combination of R and t were employed. The results of the statistical analysis have shown that none of these combinations could increase the accuracy of the model. In order to define a combined parameter for

considering the cut-out dimension, different combination of a and b were employed. The a/b showed a significant increase in the model accuracy with  $P=0.001$  in the statistical analysis.

Accuracy of the performed statistical analysis with different parameters show that the R/t, a/b and L are parameters which led to an accurate model for SCF. In order to increase the accuracy of the model, new tests were conducted based on R/t, a/b and L parameters using general full factorial method.

Based on the influence of each parameter, three levels for R/t, four levels for a/b and three levels of L are considered as listed in Table 2. Mean effects of each parameter on the SCF are shown in Fig. 10. Low effect was observed for R/t on the SCF. On the other side significant influence was observed for a/b and L. By increasing the a/b ratio and L, the stress concentration beside the cut-out was increased. The results of analysis of variance for the SCF based on the conducted tests by general factorial design are presented in Table 3. This model can predict the SCF of the structure with an accuracy about 84 percent ( $R^2 = 88.7\%$ ,  $R^2_{pred} = 84.6\%$ ,  $R^2_{adj} = 86.7\%$ ). Two insignificant factors  $R/t \times a/b \times L$  and  $R/t \times L$  were removed from the model to simplify it and then the analysis was conducted again. It was observed that these two mentioned factors could be eliminated with negligible changes in the accuracy of the model.

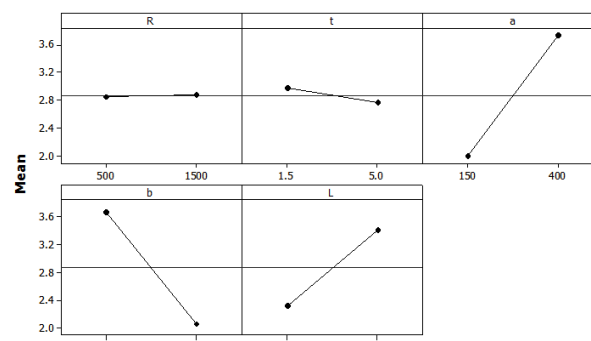

Fig. 8 Mean effects of primitive parameters on the SCF values

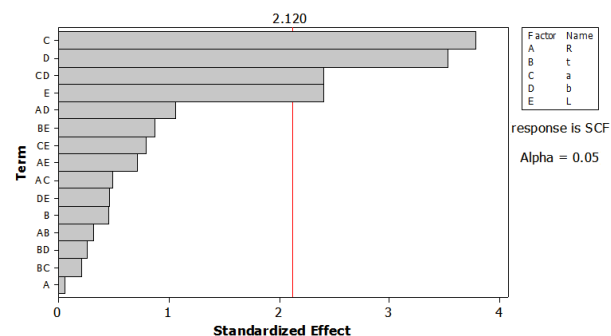

Fig. 9 Pareto chart for general linear analysis of thirty two tests

**Table 2** The considered levels for the new geometrical parameters

<i>R/t</i>	100	300	1000	
<i>a/b</i>	0.375	1	1.89	2.6667
<i>L</i>	750	1375	2000	

**Table 3** Analysis of Variance results for SCF

Source	DF	Seq SS	Adj SS	Adj MS	F	P
Main Effects	3	44.3673	41.9967	13.9989	91.74	0.000
<i>R/t</i>	1	0.7868	1.2581	1.2581	8.24	0.007
<i>a/b</i>	1	29.9790	22.2829	22.2829	146.03	0.000
<i>L</i>	1	13.6015	12.8161	12.8161	83.99	0.000
2-Way Interactions	3	3.5683	2.7689	0.9230	6.05	0.002
<i>R/t</i> * <i>a/b</i>	1	0.4081	0.5951	0.5951	3.90	0.055
<i>R/t</i> * <i>L</i>	1	0.1353	0.0975	0.0975	0.64	0.429
<i>a/b</i> * <i>L</i>	1	3.0249	2.0352	2.0352	13.34	0.001
3-Way Interactions	1	0.0571	0.0571	0.0571	0.37	0.054
<i>R/t</i> * <i>a/b</i> * <i>L</i>	1	0.0571	0.0571	0.0571	0.37	0.054
Residual Error	40	6.1038	6.1038	0.1526		
Lack of Fit	32	4.7264	4.7264	0.1477	0.86	0.651
Pure Error	8	1.3774	1.3774	0.1722		
Total	47	54.0965				
S = 0.390635		PRESS = 8.34309				
R-Sq = 88.72%		R-Sq(pred) = 84.58%		R-Sq(adj) = 86.74%		

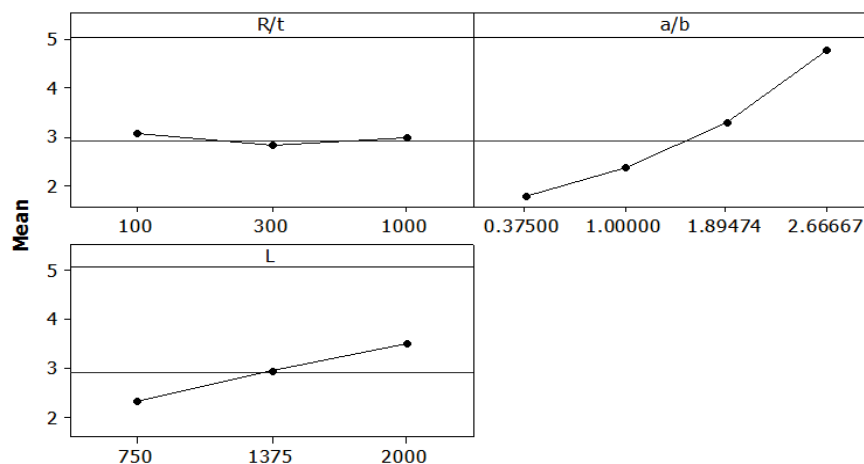

**Fig. 10** Mean effects of geometric parameters on the SCF

Interaction effects of various parameters are shown as a contour plot in Fig. 11 and Fig. 12. As illustrated in Fig. 11, for constant value of *R/t* equal to 100, for *a/b*<1 and *L*<1800 the value of SCF would be less than 2 while by increasing the *a/b* and *L*, the SCF increased up to 5. As shown in Fig. 12, the influence of *R/t* for the models with cut-out with a small *a/b* ratio was insignificant. On the other side, for higher *a/b* ratios, by decreasing the *R/t*, the SCF increased. In the following the governing equation for the SCF in a thin cylindrical shell with rectangular cut-out was presented in Eq. (2).

$$SCF = \frac{1}{1000} (0.614719 \frac{a}{b} . L - 0.0462062 \frac{R}{t} . \frac{a}{b} + 0.213817L + 330.474 \frac{a}{b} + 0.190916 \frac{R}{t} + 1028.99) \quad (2)$$

So the magnitude of maximum axial stress in cylindrical shell with rectangular cut-out can be determined by Eq. (3) with an accuracy about 84 percent ( $R^2 = 88.7\%$ ,  $R^2_{pred} = 84.6\%$ ,  $R^2_{adj} = 86.7\%$ ) where *F* is the axial compression load.

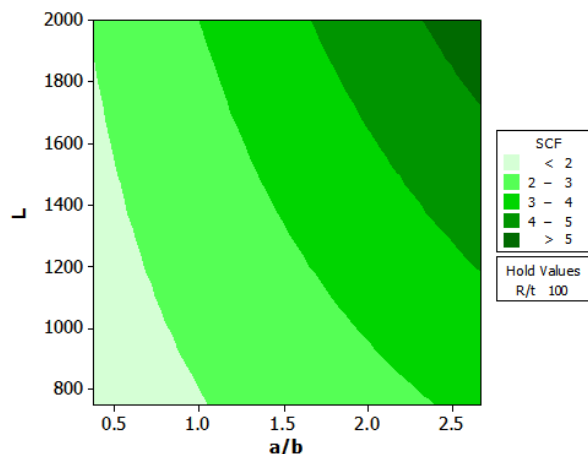

Fig. 11 Interaction effect of a/b and L parameters on the maximum stress of the shell with rectangular cut-out

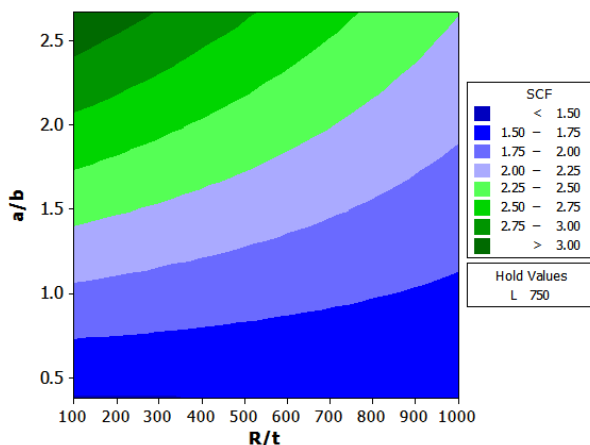

Fig. 12 Interaction effect of R/t and a/b parameters on the maximum stress of the shell with rectangular cut-out

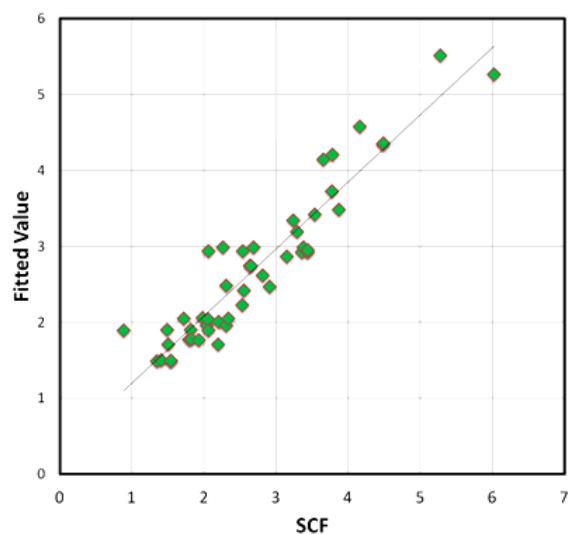

Fig. 13 A comparison between the SCF obtained from the formula and the finite element model

$$\sigma_{cutout} = \frac{F}{2\pi R t} SCF \quad (3)$$

Fig. 13 reveals that the fitted values which are obtained from the resulting formula are close to the finite element results for different studied cases which proved the acceptable accuracy of this model.

#### 4 CONCLUSION

In this paper, a parametric finite element model was prepared to study the stress concentration around the cut-out in the perforated cylindrical shells. The FE simulation shows that the critical stress was occurred in the vertical middle edge of the cylindrical shell. By the simultaneous employment of design of experiment technique and prepared parametric finite element model, the effect of geometrical parameters on the stress concentration around the cut-out was studied. The analysis of variance of the conducted studies revealed the effectiveness of the geometrical parameters on the SCF. The performed statistical analysis showed that the  $R/t$ ,  $a/b$  and  $L$  can accurately describe the stress concentration around the rectangular cut-out in the thin cylindrical shell. At the end, a formulation for predicting the stress concentration factor with accuracy more than 84% was developed which can be employed as a tool in the primary design of the perforated thin cylinders.

#### REFERENCES

- [1] Ghanbari Ghazijahani, T., Jiao, H., and Holloway, D., "Structural behavior of Shells with Different Cut-outs under Compression: An Experimental Study", Journal of Constructional Steel Research, Vol. 105, 2015, pp. 129-137.
- [2] Han, H., Cheng, J., Taheri, F., and Pegg, N., "Numerical and Experimental Investigations of the Response of Aluminum Cylinders with a Cut-out Subject to Axial Compression", Thin-Walled Structures, Vol. 44, 2006, pp. 254-270.
- [3] Naghdi, A. K., Gersting, J. M., Jr., "The Effect of a Transverse Shear Acting on the Edge of a Circular Cut-out in a Simply Supported Circular Cylindrical Shell", Ingenieur-Archiv, Vol. 42, 1973, pp. 141-150.
- [4] Aliabadi, M., Rooke, D., and Cartwright, D., "An Improved Boundary Element Formulation for Calculating Stress Intensity Factors: Application to Aerospace Structures", The Journal of Strain Analysis for Engineering Design, Vol. 22, 1987, pp. 203-207.
- [5] Theocaris, P., Petrou, L., "From the Rectangular Hole to the Ideal Crack", International journal of Solids and Structures, Vol. 25, 1989, pp. 213-233.
- [6] Folias, E., Wang, J.-J., "On the Three-Dimensional Stress Field Around a Circular Hole in a Plate of Arbitrary



- Thickness”, Computational Mechanics, Vol. 6, 1990, pp. 379-391.
- [7] Lasko, G., Deryugin, Y., Schmauder, S., and Saraev, D., “Determination of Stresses Near Multiple Pores and Rigid Inclusion by Relaxation Elements”, Theoretical and Applied Fracture Mechanics, Vol. 34, 2000, pp. 93-100.
- [8] Singh, A., Paul, U., “Finite Displacement Static Analysis of thin Plate with an Opening-a Variational Approach”, International Journal of Solids and Structures, Vol. 40, 2003, pp. 4135-4151.
- [9] Paik, J. K., “Ultimate Strength of Perforated Steel Plates under Edge Shear Loading”, Thin-Walled Structures, Vol. 45, 2007, pp. 301-306.
- [10] Rezaeepazhand, J., Jafari, M., “Stress Concentration in Metallic Plates with Special Shaped Cut-out”, International Journal of Mechanical Sciences, Vol. 52, 2010, pp. 96-102.
- [11] Woo, J.-H., Na, W.-B., “Effect of Cut-out Orientation on Stress Concentration of Perforated Plates with Various Cut-outs and Bluntness”, International Journal of Ocean System Engineering, Vol. 1, 2011, pp. 95-101.
- [12] Rezaeepazhand, J., Jafari, M., “Stress Analysis of Composite Plates with a Quasi-square Cut-out Subjected to Uniaxial Tension”, Journal of Reinforced Plastics and Composites, 2009.
- [13] Pan, Z., Cheng, Y., and Liu, J., “Stress Analysis of a Finite Plate with a Rectangular Hole Subjected to Uniaxial Tension using Modified Stress Functions”, International Journal of Mechanical Sciences, Vol. 75, 2013, pp. 265-277.
- [14] Rahimi, G., Alashti, R., “Plastic Limit Loads of Cylinders with a Circular Opening under Combined Axial Force and Bending Moment”, The Journal of Strain Analysis for Engineering Design, Vol. 42, 2007, pp. 55-66.
- [15] Kalita, K., Shinde, D., and Haldar, S., “Analysis on Transverse Bending of Rectangular Plate”, Materials Today: Proceedings, Vol. 2, 2015, pp. 2146-2154.
- [16] Thirumump, M., Kalita, K., Ramachandran, M., and Ghadai, R., “A numerical Study of SCF Convergence using ANSYS”, ARPN Journal of Engineering and Applied Sciences, Vol. 10, 2015.
- [17] Kalita, K., Shinde, D., and Thomas, T. T., “Non-Dimensional Stress Analysis of an Orthotropic Plate”, Materials Today: Proceedings, Vol. 2, 2015, pp. 3527-3533.
- [18] Santos, A., “Determination of Stress Concentration Factors on Flat Plates of Structural Steel”, in Journal of Physics: Conference Series, 2013, pp. 012035.
- [19] Verri, F. R., Junior, J. F. S., de Faria Almeida, D. A., de Oliveira, G. B. B., de Souza Batista, V. E., Honório, H. M., *et al.*, “Biomechanical Influence of Crown-to-Implant Ratio on Stress Distribution over Internal Hexagon Short Implant: 3-D finite Element Analysis with Statistical Test”, Journal of biomechanics, Vol. 48, 2015, pp. 138-145.
- [20] Cerik, B. C., “Ultimate Strength of Locally Damaged Steel Stiffened Cylinders under Axial Compression”, Thin-Walled Structures, Vol. 95, 2015, pp. 138-151.
- [21] Guoliang, J., Lin, C., and Jiamei, D., “Monte Carlo Finite Element Method of Structure Reliability Analysis”, Reliability Engineering & System Safety, Vol. 40, 1993, pp. 77-83.
- [22] Narayana, A. L., Rao, K., and Kumar, R. V., “FEM Buckling Analysis of Quasi-Isotropic Symmetrically Laminated Rectangular Composite Plates with a Square/Rectangular Cut-out”, Journal of Mechanical Science and Technology, Vol. 27, 2013, pp. 1427-1435.
- [23] Vartdal, B., Al-Hassani, S., and Burley, S., “A Tube with a Rectangular Cut-out. Part 1: Subject to Pure Bending”, Proceedings of the Institution of Mechanical Engineers, Part C: Journal of Mechanical Engineering Science, Vol. 220, 2006, pp. 625-643.
- [24] Lubarda, V. A., “On the Circumferential Shear Stress Around Circular and Elliptical Holes”, Archive of Applied Mechanics, Vol. 85, 2015, pp. 223-235.
- [25] Dimopoulos, C. A., Gantes, C. J., “Numerical Methods for the Design of Cylindrical Steel Shells with Unreinforced or Reinforced Cut-outs”, Thin-Walled Structures, Vol. 96, 2015, pp. 11-28.
- [26] Mazraehshahi, H. T., Zakeri, A., “Influence of Material and Geometrical Parameters on Stress Field of Composite Plates with Insert”, Proceedings of the Institution of Mechanical Engineers, Part G: Journal of Aerospace Engineering, 2011, pp. 1573-1582.
- [27] Kumar, A., Agrawal, A., Ghadai, R., and Kalita, K., “Analysis of Stress Concentration in Orthotropic Laminates”, Procedia Technology, Vol. 23, 2016, pp. 156-162.
- [28] Kalita, K., Halder, S., “Static Analysis of Transversely Loaded Isotropic and Orthotropic Plates with Central Cut-out”, Journal of the Institution of Engineers (India): Series C, Vol. 95, 2014, pp. 347-358.
- [29] ABAQUS 6.4 PR11 user’s manual.
- [30] Fereidoon, A., Kolasangiani, K., Akbarpour, A., and Shariati, M., “Study on Buckling of Steel Cylindrical Shells with an Elliptical Cut-out under Combined Loading”, Journal of Computational & Applied Research in Mechanical Engineering (JCARME), Vol. 3, 2013, pp. 13-25.
- [31] Jadvani, N., Dhiraj, V. S., Joshi, S., and Kalita, K., “Non-Dimensional Stress Analysis of Orthotropic Laminates”, Materials Focus, Vol. 6, 2017, pp. 63-71.
- [32] Chaloner, K., Verdinelli, I., “Bayesian Experimental Design: A Review”, Statistical Science, 1995, pp. 273-304.
- [33] Atkinson, A. C., “Optimal Experimental Design”, in International Encyclopedia of the Social & Behavioral Sciences (Second Edition), J. D. Wright, Ed., ed Oxford: Elsevier, 2015, pp. 256-262.
- [34] Graciano, C., Mendes, J., “Elastic Buckling of Longitudinally Stiffened Patch Loaded Plate Girders using Factorial Design”, Journal of Constructional Steel Research, Vol. 100, 2014, pp. 229-236.
- [35] Mason, R. L., Gunst, R. F., and Hess, J. L., “Statistical Design and Analysis of Experiments: with Applications to Engineering and Science”, Vol. 474, John Wiley & Sons, 2003.