

# Fault Location Scheme in Distribution Systems with Distributed Generators Using Neural Networks

Ghazanfar Shahgholian<sup>1</sup>, Mohammad Hosein Rezaei<sup>2</sup>

1- Department of Electrical Engineering, Islamic Azad University Najafabad Branch, Isfahan, Iran  
shahgholian@iaun.ac.ir

2- Department of Electrical Engineering, Islamic Azad University Najafabad Branch, Isfahan, Iran  
mohamadhosein.rezaei@gmail.com

Received: October 2009

Revised: January 2010

Accepted: March 2010

## ABSTRACT:

Nowadays using DG (distributed generation) in vast variety of cases has been more considerable due to its beneficial advantages, but interconnecting DG to radial distribution systems has some impact on the coordination of protection devices. The main point in the protection scheme is the diagnosis of fault locations, so producing a new method to identify fault location with high accuracy is necessary. This paper presents a novel approach to fault location identification with DG in distributed systems by the means of neural networks. According to this method using a distributed system as intentional islanding in necessary conditions is possible and reduces the ENS (Energy Not Supplied) of the net. Using separate NNs (neural networks) for each island (zone) will increase the accuracy of this method. Implementation results of this scheme on actual distributed systems has been simulated and reported.

**KEYWORDS:** Fault location, Distributed System, Distributed generation, Neural Networks

## 1. INTRODUCTION

Power distribution networks that include distributed generation (DG) need new control strategies based on distributed and hierarchical structures. DG connected to distribution networks affects the currents or power flows in the networks; thus, node voltages that are strongly related to power flows also are changed [1].

Gas turbine, solar cell, combine motor and wind turbine are well-known DG productions. Traditional electric distribution systems are radial in nature, and supplied through a main source, therefore it is simple to design a protection scheme for such networks. Recently, more attention must be paid to applying DG throughout electric distribution systems, for the presence of these generation units may result in not having a radial distribution network, which consequently raises some problems such as losing coordination of protection devices [2-7].

In this way DG has effects on the protection of distributed systems. Those effects will depend on the size, type and placement of the DG [8-11].

The main goal in protection design in distribution systems is detecting fault locations and further isolating it from the rest of the system. Some methods have been suggested for traditional distribution systems. In [2] a method for identifying fault location and separate fault zones has been suggested but this method's solution algorithm.

A genetic algorithm based approach for the simultaneous power quality improvement and optimal placement and sizing of fixed capacitor banks and distributed generation DGs in radial distribution networks in the presence of voltage and current harmonics presented in [12]. In [13] another method for solving this problem in symmetrical point by omitting fault resistance has been introduced but in this case the accuracy depends on the number of DGs. Moreover, this method does not include minor branches. In [14] the problem has been optimized by considering secondary branches affected and revenue operations in islanding state but this method does not provide the essential accuracy needed and only fault regions is diagnosed. In the recent years neural networks usage for fault location identification in power systems has been mentioned [15, 16].

In this paper by using generalizing power of Neural Network (NN) and dividing distribution net and using separate neural networks for each zone, the accuracy of fault location diagnosis has been increased. In the next stage the suggested method is introduced, then simulated and tested in a real system.

## 2-THE SUGGESTED METHOD

Protection methods in distributed systems with DG consider two objectives: identifying fault location and also the possibility of optimizing the use of DG when fault happens and ENS (Energy Not Supplied) of the

network reduces. Therefore, in this paper, a novel approach is suggested that faces two objectives: I- identifies fault locations II- identifies the possibility of optimizing the use of DG. In this method, distributed system zones are divided into two classes: regions with a DG and regions without DGs. As Figure 1 shows ANN1 has been programmed to have two outputs: zero or one.

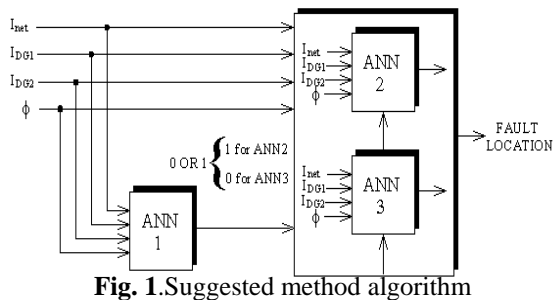

Fig. 1. Suggested method algorithm

One indicates that faults have happened in the first region and zero shows that faults have happened in the second region. Then depending on the output of ANN1, one of the trained NNs that are used for fault location identification will be activated. Finally fault locations will be defined with high accuracy. Neural networks are trained with three-phase current vector of net and DG and also a fault angle. With divided regions and selected separate NNs for each zone, the accuracy of diagnosis will increase. All minor branches have been investigated for security of fault diagnosis. The other advantage of this method is the possibility of using it in the islanding mode when faults occur.

### 2-1- Net devising Process

For using net in the islanding mode and reducing the ENS of net, processes are divided as bellow: From the beginning of the feeder each DG on the region is considered until that DG can provide region loads. This means DG product and region loads must be the same. If before the region is going to be ended, other DG

connects to this region, this second DG must also be considered in this zone. In this case the product of two DGs and region loads must be the same, too. During the region spreading before DG production and when the region peak is going to be ended, if any other DG exists then the 2nd DG is connected as a member of this region.

### 2-2- Case Study

In Figure 2 the actual distributed network line in Shiraz city, Iran is shown. This system has been chosen as the test system. This feeder is 20kw.13000 meter long and has 27 buses that feed by 63/20kw trans. Test system data are available in the appendices. Two distributed generations with YG configuration is interconnected to the network. The best method to obtain input data including training data for neural networks and test vectors is data collection from real networks. In this paper NEPLAN software is used for the modeling of the system and MATLAB software for evaluating the protection procedure and executing neural networks based on the fault locator. The capabilities of multi-layered feed forward neural network to deal with nonlinearities and the nature of online fault location leads to selecting the perception multilayered neural network as a solution [17]. Back propagation error is considered as a well-adapted training algorithm for the network. This network with one input layer, one output layer and maximum two hidden layers with adequate neurons can extract every relation function between the input and output layers [18].

The three layer feed forward has been selected in our work. The number of neurons for hidden layers has a liner relation with the system dimension and will be identified with the trial error procedure. Two neurons have been chosen for the output layer, one of them shows the base bus to fault and the other one shows the fault distance to this bus. In this case, the base buses for the regions without DGs are 1, 10, and 15 and 1, 6 and 24 for the other regions.

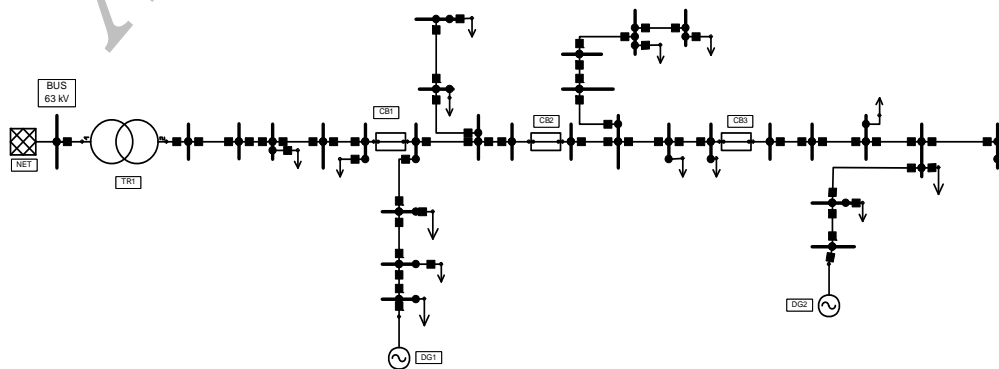

Fig. 2. Single line diagram for the test system

The sigmoid and purline function have been chosen as the transfer functions of the hidden and the output layer respectively, based on experimental. In the next session, the simulation results for two important short circuits: single phase short circuit and three phase short circuit are presented. Figures [3-7] show the result of the test input data, which has been chosen randomly and differ from the training data input. Tables (1-5) are used for determining the NN precision. In these tables real fault locations (base buses and fault distance from these buses) and error percentages are presented. Equation (1) will be used to estimate the error of fault locations

$$\varepsilon\% = \frac{|\text{ActualDist} - \text{calculatedDist}|}{\text{TotalLineLenght}} * 100 \quad (1)$$

**3. Simulation Results**

In this section the simulation results are provided and discussed.

**3-1-Single Phase Short Circuit**

For simulating the network fault, level data of points are used which are 10m far from one another. Total input (1200) data of all parts are used to train the ANN1. Zero outputs indicate the regions without DG (zone 1, 3) and the ones show the regions with DG (zone 2, 4). 50 different locations with training steps have been tested to detect the generalizing power of the NNs. The maximum distance with the normal output of the ANN1 (zero and one) is  $6.2 \times 10^{-2}$  in the training step and  $1.3 \times 10^{-2}$  in the test step which shows the accuracy of the neural networks. The current vector and the fault angle are chosen randomly for the testing system. Figure 3 shows the output data of ANN1 in the test step. 420 data sets have been used for training the ANN2 (zone 2, 4). The average error is  $9.6 \times 10^{-2}$ .

To define the accuracy of the ANN2, 30 points are chosen randomly which are not used in the training step. Figure 4 shows the result of the training and then the test step. Table 1 shows the performance of the test step for single phase short circuit.

920 data sets have been used for training the ANN3 regions without DG, zones (1, 3). The average error in the training step is 0.057 and 30 points are chosen randomly for the test system. Figure 5 and Table 2 show the results.

**3-2-Three Phase Short Circuit:**

All input data are used for training the ANN1 and also for examining the accuracy of neural networks to find the fault location. 30 points are chosen randomly for the test NNs that differ from the training step. The number of data for training NN in a single fault short circuit and three phase short circuit are the same. The maximum output error for the training step is  $3.04 \times 10^{-6}$

and  $1.3 \times 10^{-5}$  in the test step. ANN2 has been used for regions with DG (zone 2, 4) and also 30 data sets have been chosen.

Figure 6 and Table 3 show the result of the simulation. ANN3 has been used for training regions without DG (zone1, 3). 35 data sets are chosen randomly to test this NN and average error is 0.18 in the test step. Figure 7 and Table 4 show the results.

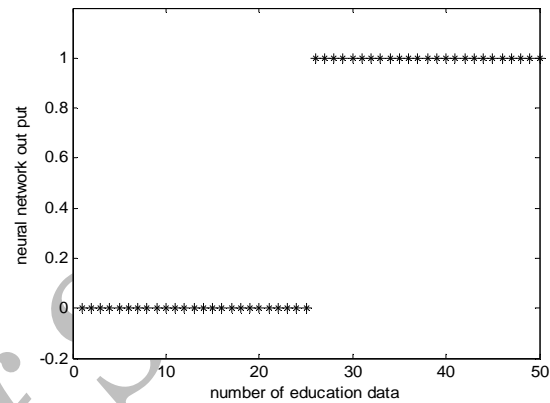

Fig. 3. Test result of ANN1 for single short circuit

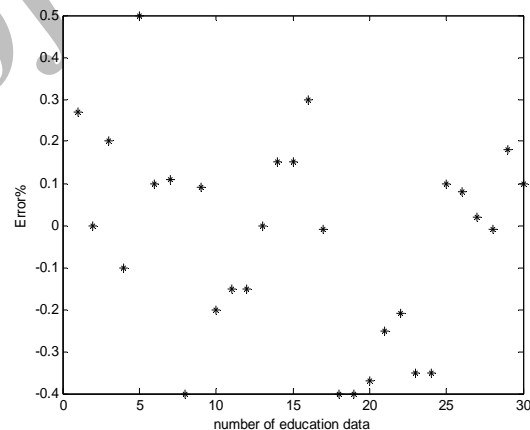

Fig. 4. Test result of ANN2 for single short circuit fault

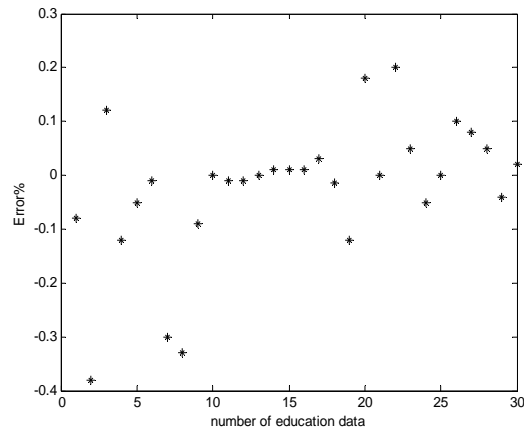

Fig. 5. Test result of ANN3 for single phase fault short circuit

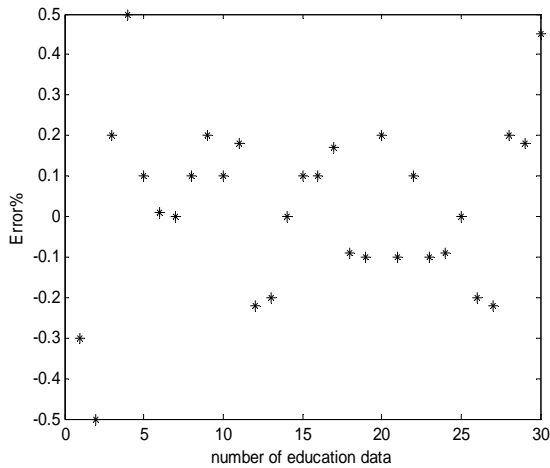

Fig. 6. Test results of ANN2 for three phase short circuit

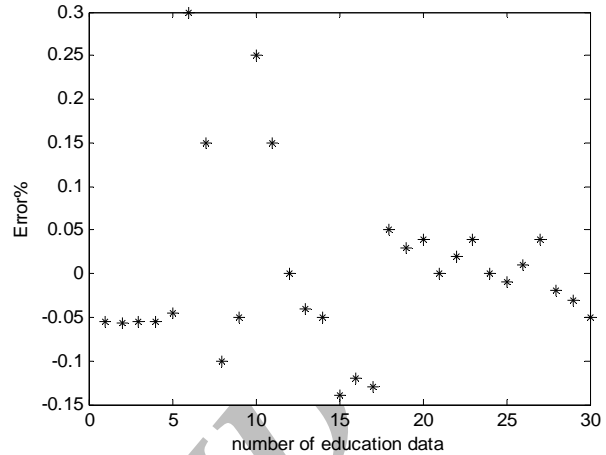

Fig. 7. Test results of ANN3 for three phase short circuit

Table 1. Test result of ANN2 for single short circuit fault

	Fault distance from base bus fault (meter)	Fault angel (degree)	Fault location error %		Fault distance from base bus fault (meter)	Fault angel (degree)	Fault location error %
Bus 10	88	325	0.32	Bus 10	277	55	0.10
Bus 15	148	125	0.08	Bus 15	34	25	0.06
Bus 1	332	75	0.52	Bus 1	166	10	0.58
Bus 10	25	45	0.44	Bus 10	93	225	0.42
Bus 1	464	10	0.23	Bus 1	15	95	0.35

Table 2. Test result of ANN3 for single short circuit fault

	Fault distance from base bus fault (meter)	Fault angel (degree)	Fault location error %		Fault distance from base bus fault (meter)	Fault angel (degree)	Fault location error %
Bus 1	869	3	0.06	Bus 1	1127	333	0.36
Bus 1	954	7	0.04	Bus 1	1222	235	0.02
Bus 6	56	265	0.28	Bus 6	87	25	0.32
Bus 24	145	95	0.02	Bus 24	237	215	0.02
Bus 1	85	85	0.17	Bus 1	166	185	0.12

Table 3. Test results of ANN2 for three short circuit fault

	Fault distance from base bus fault (meter)	Fault angel (degree)	Fault location error %		Fault distance from base bus fault (meter)	Fault angel (degree)	Fault location error %
Bus 1	915	110	0.29	Bus 1	1127	333	0.36
Bus 1	877	120	0.5	Bus 1	1222	235	0.02
Bus 6	128	200	0.04	Bus 6	87	25	0.32
Bus 6	286	145	0.22	Bus 6	237	215	0.02
Bus 24	121	190	0.15	Bus 24	166	185	0.12

**Table 4.** Test results of ANN3 for three short circuit fault

	Fault distance from base bus fault (meter)	Fault angel (degree)	Fault location error %		Fault distance from base bus fault (meter)	Fault angel (degree)	Fault location error %
Bus 1	73	115	0.07	Bus 1	335	15	0.08
Bus 10	41	15	0.05	Bus 10	186	35	0.091
Bus 15	354	0	0.13	Bus 15	265	165	0.036
Bus 10	18	240	0.44	Bus 10	112	345	0.42
Bus 1	775	10	0.21	Bus 1	593	15	0.126

**Table 5.** Generator data

GEN	KV	S (MVA)	PR	Cos
GEN 1	20	0.625	0.5	0.8
GEN 2	20	0.2	0.16	0.8

**Table 6.** Transformer input data

	PRIM (KV)	Sec (KV)	MVA	Type
T 1	63	20	0.8	YG

#### 4. CONCLUSION

The DG systems are presented as a suitable form to offer highly reliable electrical power supply. In this paper a new method for evaluating location accuracy and speed is presented. For increasing the accuracy of fault location diagnosing, the distribution system is divided into sub-systems by the proposed algorithm. Then separate neural networks have been used for each region. Simulation results indicate that this method has high accuracy for determining fault location.

#### REFERENCES

- [1] Chun-Lien S.; "Stochastic Evaluation of Voltages in Distribution Networks With Distributed Generation Using Detailed Distribution Operation Models", *IEEE Trans. on Pow. Sys.*, Vol. 25, No. 2, pp.786-795, (May 2010)
- [2] Brahma S.M., Girgis A.A.; "Development of Adaptive Protection Scheme for Distribution Systems with High Penetration of Distributed Generation", *IEEE/PES*, Vol. 4, (July 2003)
- [3] Barker P. P., Mello R.W. de, "Determining the Impact of Distributed Generation on Power Systems: Part1-Radial Distribution Systems", *IEEE Trans. Power Delivery*, Vol. 15, pp. 486-493, (Apr. 2000)
- [4] Dugan R.C., McDermott T.E., "Operating conflicts for Distributed Generation interconnected with Utility Distribution Systems", *IEEE Industry Applications Magazine*, 19-25, Mar/Apr. 2002E. Clarke, *Circuit Analysis of AC Power Systems*, Vol. I. New York: Wiley, p. 81, (1950)
- [5] Guerrero J.M., Blaabjerg F., Zhelev T., Hemmes K., Monmasson E., Jemei S., Comech M.P., Granadino R., Frau J.I.; "Distributed Generation: Toward a New Energy Paradigm", *IEEE Indu. Elec. Mag.*, Vol. 4, No. 1, pp.52-64, (March 2010)
- [6] Xiao-bo T., Guo-qing T., "Power Flow for Distribution Network with Distributed Generation", *IEEE/APPEEC*, pp.1-4, Chengdu, (March 2010)
- [7] Freitas W., Vieira J.C.M., Morelato A., Silva L.C.P., Costa V.F., Lemos F.A.B.; "Comparative Analysis Between Synchronous and Induction Machines for Distributed Generation Applications", *IEEE Tran. On Pow. Sys.* Vol. 21, No. 1, pp. 301-311, (February 2006)
- [8] Marwali M.N., Keyhani A., "Control Of Distributed Generation Systems-Parti: Voltage And Current Control", *IEEE Trans. On Pow. Elect.*, Vol. 19, No. 6, pp. 1541-1550, (November 2004)
- [9] Brown R.E., "Modeling The Reliability Impact Of Distributed Generation", *IEEE/PSS*, Vol. 1, No. 25, pp. 442-446, (July 2002)
- [10] Rezaei M.H., Shahgholian G., "A New Approach for Appointment of Fault Location in Distribution System with Distributed Generation Using Neural Networks", *EPDC, Kerman, Iran*, (2009)
- [11] Tang G., Iravani M.R., "Application of a Fault Current Limiter to Minimize Distributed Generation Impact on Coordinated Relay Protection", *IPST (International Conference on Power Systems Transients)*, (June 2005)
- [12] Mady I; "Optimal Sizing of Capacitor Banks and Distributed Generation in Distorted Distribution Networks by Genetic Algorithms", *IEEE/ICEED*, pp. 1-4, (June 2009)
- [13] Rezaei N., Haghifam M.R.; "Protection Scheme for A Distribution System with Distributed Generation Using Neural Networks", *Inter. Jour. of Elec. Pow. & Ene. Sys.*, Vol. 30, No. 4, pp. 235-241, (May 2008)
- [14] Hagifam M., Javadian S.A.M., "New Methods for Protection Distribution System With Dg and Simulation Real Net", *20th international conference power, Tehran Iran*, (2007)
- [15] Martins L.S., Martins J.F., Alegria C.M., Pires V.F., "A Network Distribution Power System Fault Location

- Based on Neural Eigenvalue Algorithm”, *IEEE/PTC*, Vol. 2, (Jun3 2003)
- [16] Gracia J., Mazon A.J., Zamora I.; “**Best Ann Structures For Fault Location in Single and Double-circuit Transmission Lines**”, *IEEE Trans. on Pow. Deli.*, Vol. 20, No. 4, pp. 2389-2395, (Oct. 2005)
- [17] Hoseini Naveh S., Haghifam M.; “**Fault Location Algorithm for Underground Cable with Neural Network**”, *M.S. Thesis, Dept, Electron Eng., Tarbiat Modarres Univ., Tehran, Iran*; (2002)
- [18] Al-shaher M.A., Sabryb M.M., Saleha A.S., “**Fault Location in Multi-ring Distribution Network Using Artificial Neural Network**”, *Elec. Pow. Sys. Res.*, Vol. 64, No. 2, pp.87-92, (February 2003)

Archive of SID