

Hydrogen use in an urban district: environmental impacts a possible scenario based on coal

¹Marco Gambini, ²Michela Vellini.

^{1,2}Dept. of Industrial Engineering, University of Rome "Tor Vergata" Via del Politecnico n. 1, 00133 Roma

Received Date 10 Aug. 2011

Accepted: 16 Nov. 2011

ABSTRACT

Hydrogen technology is becoming ever more relevant because hydrogen use can help containing greenhouse gas emission if CO₂ capture and storage techniques are implemented in the hydrogen production technology (when hydrogen is produced from fossil fuels). For this reason this work aims at carrying out a comparative analysis of possible energy scenarios in urban districts: a medium-small Italian city is taken into consideration, and its energy consumptions, both for domestic and industrial use, are evaluated. The current situation, in which conventional technologies meet the energy needs, is compared to a hypothetical scenario where clean energy vectors, namely hydrogen and electricity, are utilized together with traditional primary energy supply. Hydrogen production by means of coal decarbonization is investigated, as well as hydrogen use in advanced energy systems for transport and for electric and thermal energy generation.

Keywords

hydrogen, CO₂ capture and storage, clean energy vectors, coal decarbonization

1. Introduction

It is well known that one of the most challenging problems that mankind is facing for the (near) future is how to satisfy the ever-increasing energy needs. Every human activity is based predominantly on fossil fuels; the ongoing challenge is to use them in the cleanest and most efficient way. Therefore the world institutions have long begun to pursue the so-called Sustainable Development: in 1992 an international treaty was drafted, the United Nations Framework Convention on Climate Change, with the purpose of identifying possible paths toward greenhouse gas emission reduction. Updates to this treaty led to the definition of several "Protocols", among which the most important and renowned is the Kyoto Protocol, whose aim is to stabilize the concentration of greenhouse gases in the atmosphere, so as to limit the harmful effects of anthropogenic activities on climate. The Kyoto Protocol came into force on 2005, February 16th, after Russia's ratification. Italy's commitment is to reduce its national greenhouse gas emission by 6.5% with respect to

the 1990 levels. In order to meet this requirement Italy has defined and approved a National Plan for Greenhouse Gas Emission Reduction ("Piano nazionale per la riduzione delle emissioni di gas responsabili dell'effetto serra", CIPE deliberation, 2002, December 19th).

In this context hydrogen technology is becoming ever more relevant because hydrogen use can help containing greenhouse gas emission if CO₂ capture and storage techniques are implemented in the hydrogen production technology (when hydrogen is produced from fossil fuels).

This paper aims at carrying out a comparative analysis of possible energy scenarios in urban districts: a small Italian city is taken into consideration, and its energy consumption, both for domestic and industrial use, are evaluated. The current situation, in which conventional technologies meet the energy needs, is compared to a hypothetical scenario where clean energy vectors, namely hydrogen and electricity, are utilized. Hydrogen production from coal is investigated, as well as

* Corresponding author: Marco Gambini (e-mail gambini@ing.uniroma2.it:)

hydrogen use in advanced energy systems for transport and for thermal and electric energy generation.

Finally, paying attention to the carbon dioxide emission, this paper aims at carrying out an economic evaluation to quantify, in monetary terms, the primary energy surplus, which is required to reduce carbon dioxide emissions, in order to estimate the cost of carbon dioxide emission avoided. All costs related to the implementation of the new plants in the innovative scenario will be neglected because the scope of this work will be identifying sectors where global strategies and specific measures must be implemented in order to meet the energy needs with the lowest environmental impact.

2. Abbreviations:

LCA	Life Cycle Assessment
LPG	Liquefied petroleum gas
ACI	Automobile Club Italia
TERNA	Trasmissione Elettricit� Rete Nazionale, Rome, Italy
SINANet	National Environmental Information System
APAT	(National Environment Protection Agency)
ANFIA	National Automotive Industry Association
CORINAIR	Coordination-Information on Air
EU	European Union
SNAM	SNAM RETE GAS (San Donato Milanese, Milan, Italy)
EMEP-CORINAIR	Atmospheric emission inventory published by EEA (European Environment Agency)
PAFC	Phosphoric Acid Fuel Cell

3. The Case study

As the object of this analysis, a small city of central Italy, Pisa, was chosen. Many detailed information about its energy needs were in fact available [1, 2, 3]; furthermore, a large number of industrial, tourism, commercial and tertiary activities make it an interesting case, and the results can be usefully extrapolated to more complex contexts.

The urban context taken into consideration is characterized by approximately 90000 inhabitants, with an average density of 500 inh./km². The territory is basically plain and climate typically Mediterranean, i.e. temperate with mildly hot summers and not too harsh winters [1].

The economic structure of such an urban context is predominantly based on the tertiary industry, with particular reference to tourism and commerce. More specifically, a particularly intense activity is centered on advanced services offered by three important hospitals, two prestigious universities, a renowned research center and an airport, which serves both civil and military uses [2, 3].

The city represents an outstanding tourist attraction thanks to its remarkable cultural and historical heritage, as well as to its beautiful landscapes; it is also marked by typical seasonal (summer) tourism, due to its proximity to seaside structures. Tourists are present in all seasons, albeit prevalently in spring and fall. Tourist visits are usually concentrated in the city center due to the presence of architecturally exquisite buildings and museums. It was assumed that tourist presence is usually short (3 days stay on average) [2, 3].

The commercial activity can be divided into two main sectors: small retailers in the city center and large-scale retail trade, organized in three big shopping malls, in the city outskirts [2, 3].

The industrial activity is based on the construction and pharmaceutical sectors and, to a lesser extent, on the textile, clothing, furniture and glass industries. The agricultural sector plays a minor role, in terms of both number of employees and profit (it is mainly based on sowable land) [2, 3].

The demand for transport is rather high, as it happens at a national level (this is explained by a high average income, by citizens' way of life, by the scattering of residential and production areas, etc.) [1, 2, 3]. Within this context, road transport for both passengers and goods is absolutely pre-eminent. The intensity of road traffic is at the origin of negative externalities in terms of environmental impacts, as it will be confirmed by the results of this analysis. These impacts can be found at a global level (climate change and large-distance pollution) and at a local level (acoustic pollution along the main roads, small-distance atmospheric pollution and damage to the soil sta-

bility, to the hydrogeological equilibrium and to the landscape). The urban context taken into account is therefore marked by a high mobility density since a large and articulate presence of residential, commercial, tourism and production activities has been considered. However, the indications from the transport sector lead to the assumption that, in the near term, there will not be drastic changes, especially in the private transport scenario. In this work, therefore, the alternatives to traditional fuels will be considered with reference only to public transport, and particularly to those vehicles destined to the city center service. Furthermore, a certain degree of disaffection towards public transport, resulting in a low usage level, has been considered [2, 3].

The model of the urban context is particularly focused on the traditional energy source utilization and on the production and utilization of the energy vectors taken into account. All the accessory phases of mining, transport and storage of fossil fuels, as well as the capital energy needed for the realization of all the plants considered, have been left out of this study; in this preliminary phase, in fact, it is necessary to define the possible convenience of the proposed scenario in terms above all of environmental impact; if such a study gave positive results, then the analysis of the operations upstream and downstream to the energy sources utilization and to the production of the energy vectors should be investigated, in order to globally assess the performance of a hydrogen scenario. However, it is important to emphasize that, particularly in the case of capital energy, retrieving reliable data can be at present extremely difficult (if not outright impossible), and equally restrictive is the utilization of data included in commercial software tools, which refer to specific industrial plants, located in different geographical contexts than the national one.

4. Present Scenario

The model of the present scenario has been carried out as follows (Fig. 1):

- electric energy production is based on fossil fuels (coal, oil and natural gas) and on renewable energy sources (hydraulic, geothermic, wind and photovoltaic energy sources);

- thermal energy production, since a district heating network is not currently in place, is provided by boilers predominantly fed with natural gas, but also with oil and LPG;
- city transport, both public and private, considers the buses' journeys inside the municipal area, as well as the daily transfers made with private cars, motorcycles and commercial vehicles, which are fueled by gasoline, diesel oil and LPG, according to quantitative data made available by ACI (Automobile Club Italia) for central Italy regions [4].

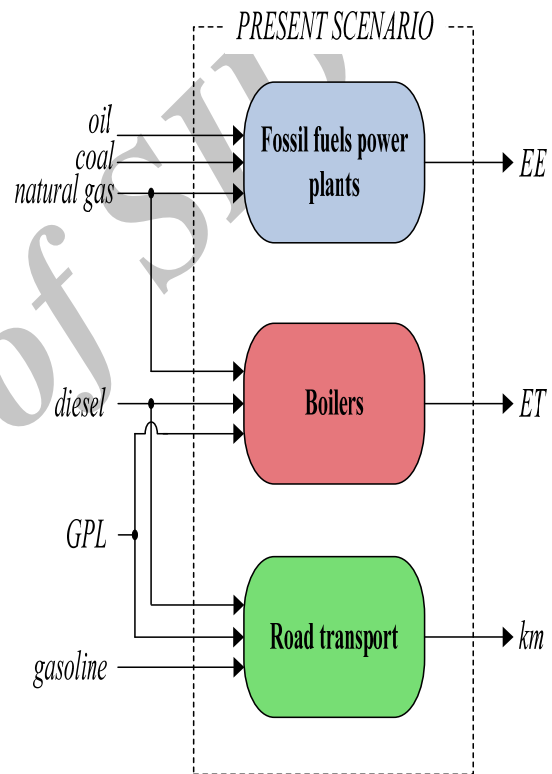

Fig. 1: Model of the present scenario

About the results, the functional unit adopted in this work is the year. Energy consumption of any country is indeed referred to the year; electrical and thermal energy will therefore be expressed as GJ/year, whereas for the transport sector the unit will be km/year. Since each season is included in one year, this functional unit is able to take into account the consumption variability as a function of climatic conditions.

More specifically, the input tables for the present scenario were built as follows.

5. Electric energy production

The Italian average electric energy production has been considered. In order to quantify the primary source consumption and to define the relative emissions, due to the electric energy requirements of the urban context, the average efficiency for fossil fuel utilization in Italy has been taken into account [5]. From TERNA data (2006), in Italy almost 83% of the electric energy production is based on fossil fuels. Coal is completely used in steam turbine power plants with an average efficiency of 37.4%; oil is almost completely used in steam turbine power plants with an average efficiency of 36.8%; almost 21% of the natural gas is used in steam turbine power plants with an average efficiency of 37.4%, and the remaining part is burnt in combined cycle power plants, with an average efficiency of 54.3% [6]. Taking into account typical emissions from these plants (in terms of CO₂, NO_x and CO), as found in the technical literature [7-9], the input table for electric energy production could be prepared. The reference unit for this input table is the "MJe".

6. Public and private conventional transport

Urban transport is made up of all transfers of private and commercial vehicles and of motorcycles, within the urban area under study. Cars have been considered as gasoline-, diesel- or LPG-fueled, in order to give the most realistic representation of the vehicles present in an Italian city. Information about pollutant emissions from cars have been obtained by the data base set up by SINAnet (National Environmental Information System) [10]. Data related to emissions and consumptions of vehicles considered in this study refer to the EURO II European Union norm. This choice accounts for a representation of the whole set of vehicles, where not only more modern (EURO III and IV) models are certainly found, but also older and more polluting vehicles. The emissions and consumptions of gasoline cars refer to displacements of 1400 to 2000 cc, which also in this case can be considered as representative of most vehicles; displacements up to 2000 cc were considered for the evaluations of emissions and consumptions of diesel vehicles, whereas for LPG vehicles the data base does not give further subdivisions based on engine displacement.

The SINAnet data base does not organize motorcycles based on the EU regulations on pollution, but only on engine displacement. Therefore, four strokes gasoline motorcycles with displacement up to 250 cc have been taken into account in the model.

Commercial vehicles were considered as diesel-fueled vehicles with a transport capacity of up to 3.5 t. This choice has been deemed appropriate to the urban context considered.

As far as public transport is considered, every trip made within the municipal area has been taken into account, and therefore both the regular trips for passenger transport and the out of service trips (transfers to and from the bus depot) have been considered. Useful data related to the public vehicles at disposal could be obtained by an explicit reference to a transport company located in central Italy ("Compagnia Pisana Trasporti") [11]. Therefore, the assumption is made in this work that 75 diesel buses, averaging 9 years of service, were at disposal for the urban service. In order to obtain the emission data related to these vehicles, the SINAnet data base was once again consulted, taking into consideration the data related to conventional urban buses [10].

Average consumption of any transport vehicle is obtained by ACI tables (Table 1)

According to these data the six input tables necessary to describe the transport system in the urban context were built; these input tables have the "km•vehicle" unit as reference unit.

Table 1: Average consumption of any transport vehicle

	Hi [kcal/ kg]	ρ [kg/l]	Cibsynotuib [km/l]
Car (g)	10400	0.734	9
Car (d)	10200	0.833	15
Car (LPG)	11000	0.565	9
Motorcycle	10400	0.734	16
Truck	10200	0.833	4
bus	10200	0.833	4

7. Heating (boilers)

Thermal energy production for heating purposes required the modeling of methane, diesel and LPG boilers; obviously, natural gas is predominantly used. Data about emissions from boilers could be found in the SINAnet data base and refer to residential boilers with a power output lower

than 50 MW. The data base contains both the measurements made directly by APAT, in cooperation with SNAM, over a sample of Italian installations, and the survey made by the international agency EMEP-CORINAIR; the first one has been chosen for this study, since they are the most appropriate to the Italian technological level [10]. Average efficiencies are evaluated as 85% for methane boilers and 80% for other boilers.

According to these data the three input tables necessary to describe the whole urban heating system could be built; the reference unit for these input tables is the "MJt".

The model of the present scenario requires that every unit operation previously described is assembled in a single input table. During this phase, the energy requirements for this scenario must therefore be evaluated.

The average national consumption of 5,5 MWh/year/person has been considered for the electric energy requirements of the urban context under study. Based on the economic activities of the city of Pisa, the electric energy needs have been subdivided as follows [1, 2, 3] (Table 2).

A series of thermal energy users has been singled out:

Residential users: the total annual consumption for this sector has been previously assessed as 113,5 GWh/year; with the assumption that residential consumption of electric energy is 3500 kWh/year for each house [12], it is possible to estimate the total number of houses present in the urban context considered. The resulting value of 32500 houses is acceptable since it corresponds to 3 persons per house on average. In order to quantify the annual thermal energy requirements of the domestic sector (for heating and hot water), an average value of 13000 kWh/year for each house has been considered [12];

Tourism: in this sector two different types of facilities have been singled out: hotels, open all year long, and complementary facilities that

are usually closed in winter. Considering the intense tourist activity, with a density of 16 tourists/inhabitant and an annual number of 120-125 tourists for each sleeping accommodation [2, 3], the total number of sleeping accommodations has been estimated as 11700: this total value has then been subdivided into the two types of facility previously described, and specifically in 4500 accommodations equally distributed among the 10 hotels present, and 7200 accommodations available through the complementary facilities. The annual average consumption per accommodation has been assumed as 5600 kWh/ year/ accommodation in the case of the hotels (that are continuously open, but on the other hand are located in a temperate climate area), and as 3500 kWh/year/accommodation for the complementary facilities that are closed during winter [12];

Hospitals: an intense hospital activity has been assumed, organized in one large-scale, one medium-scale and one small scale hospital. The technical literature for this sector provides the data for the thermal energy needs of each accommodation. The total numbers of accommodations are respectively 990, 450 and 160 for the large-, medium- and small-scale hospitals (total of 1650 hospital accommodations in the city) [2, 3, 13]. The thermal energy requirement has been assumed as 16000 kWh/accommodation [12];

Large retailers: three big shopping malls have been considered, with the following data: selling area 13000 m², covered area 20000 m² and volume 100000 m³ [12]. The thermal energy needs are estimated as 2171 MWh/year on average [12];

Other thermal energy uses: the thermal energy requirements of other sectors not previously considered (such as small retailers, education, offices, sport facilities, etc.) has been estimated on a lump-sum basis as 25% of the total civil thermal energy uses, including residential and tertiary uses;

Agriculture and industry: since in the particular city under study agricultural and industrial activities are of limited importance, their thermal energy requirement has also in this case

Table 2: Electric energy needs

Tertiary	49.50 %	GWh/year
Industry	27.40 %	GWh/year
Domestic	22.70 %	GWh/year
Agriculture	0.40 %	2.0 GWh/year
Total:		500 GWh/year

been evaluated as a fixed percentage (10%) of the total usage in the civil sector

The following overall distribution of thermal energy consumption among different sectors is obtained (Table 3).

In the case of the transport sector, in the urban context here examined, a particularly high motorization rate has been considered, assuming 75 vehicles per 100 inhabitants (including not only private vehicles, but also taxis, police cars, public institution vehicles, and so on). The resulting total number of vehicles is therefore 67500 [1, 2, 3]. These vehicles have been sorted out according to the type of fuel, based on ACI data relative to a central Italy area [4]. On the basis of such information the following distribution has been assumed:

- gasoline: 73,40%, 49600 vehicles, 15000 km/year
- diesel : 23,30%, 15700 vehicles, 19000 km/year
- LPG: 3,30%, 2200 vehicles, 10000 km/year

The information on the average distance traveled by each vehicle in a year has also been deduced by ACI data [12].

An average density of 11 motorcycles per 100 inhabitants has been assumed [1, 2, 3], resulting in a total number of 10000. The average distance traveled has been considered as 4000 km/year.

All trucks are diesel-powered and their number has been estimated as 5% of the total vehicle number, resulting in 3500 trucks with a transport capacity of up to 3.5 t. The average distance traveled each year has been assumed as 30000 km/year.

Table 3: Thermal energy consumption

	[Tj/y]
Residential	1521.0
Tourism	181.4
Hospitals	95.04
Shopping malls	23.45
Other uses	607.0
Agriculture/ Industry	270.0
Total	2698

The distance traveled by a single public bus has been estimated, on the other hand, as 50000 km/year. The transport network of the city has

been assumed as 230 km long with 20 different bus lines; the maximum number of buses simultaneously operating has been assumed as 50 [11]. The resulting total distance traveled each year is therefore $2500 \cdot 10^3$ km.

8. Energy consumption assessment and emissions in the present scenario

At this point it is possible to evaluate the consumption of the primary energy sources and its distribution among different sectors (Fig. 2-3). These results perfectly agree with data declared by municipal authority of the chosen city [1, 2, 3].

According to the results presented, the most used energy source is natural gas (covering almost 47% of the total energy needs), while gasoline and diesel oil have similar shares (23.4% and 21.7% respectively); coal is marginally used (7.5%) while LPG has a very little share (only 0.7%).

The transport sector accounts for the biggest share of primary energy consumption (38.6%), above electric energy production (34%) and thermal energy production (27.4%).

About the results, this work is focused on the emission of greenhouse gases as defined in the Kyoto protocol [14, 15], and therefore in what follows the results of simulation of the proposed scenario are given. The GWP index at 20, 100 and 500 years will be used as a final indicator of the influence of each scenario on the greenhouse effect; although it is not possible to quantify the actual reduction of this "effect", it is nonetheless evident that a remarkable reduction of the impact is certainly going to produce a significant reduction of the related effect. As the greenhouse effect is considered a global effect, because of the behavior of greenhouse gases in the atmosphere and for their residence time into the environment, GWP is considered as the best term of comparison, since it takes into account all greenhouse gases emitted by human activities and allows quantifying the harmful effects of emissions over time.

In what follows the annual greenhouse gas emissions (CO₂, CO, CH₄, and N₂O), other air emissions (NO_x, NH₃, VOC and PM) and the GWP are presented.

In this first present scenario considered, among greenhouse gases CO₂ was by far the

most relevant emission; the other greenhouse gases, sorted in descendent order, are CO, N₂O and CH₄. Other significant non-greenhouse gas emissions are those of NO_x and VOC (Volatile Organic Compounds), whereas NH₃ emissions are nearly absent (Fig. 4).

It is important to notice that GWP is going to slightly increase from 20 years to the 100 years timeframe, whereas it decreases from 100 to 500 years. This is due to the fact that in the case of N₂O its coefficient for the determination of GWP peaks at 100 years. Fig. 4 describes also how the different greenhouse gases emitted in the present scenario affect the 100 years GWP: 94.6% of GWP is determined by carbon dioxide (thus confirming researchers' concern about carbon dioxide as the main cause of greenhouse effect); the difference from the other gases (CO, N₂O and

CH₄) is still abysmal but lower than the difference among simple emissions, because of the larger influence of these gases on greenhouse effect (resulting in larger multiplicative coefficients in the determination GWP).

A correct comprehension of the results, and their consequent usage for undertaking corrective actions, cannot be accomplished leaving out the analysis of emissions according to the activity that generated them in the first place. Fig. 5 shows how emissions are generated respectively by electric energy generation, by thermal energy generation and finally by transport applications; the same figure gives for these three sectors the percentage of total CO₂ emissions, which have been shown to be by far the most important factor both as quantity effect and as impact on the greenhouse effect.

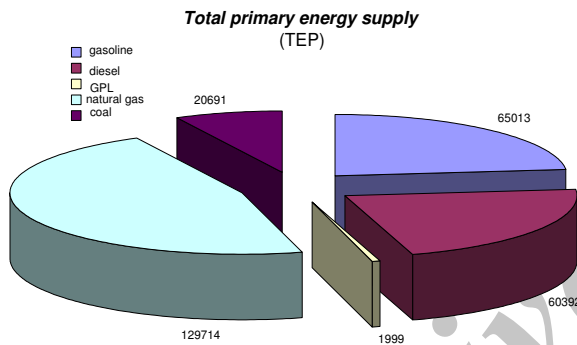

Fig. 2: Consumption of primary energy sources (present scenario)

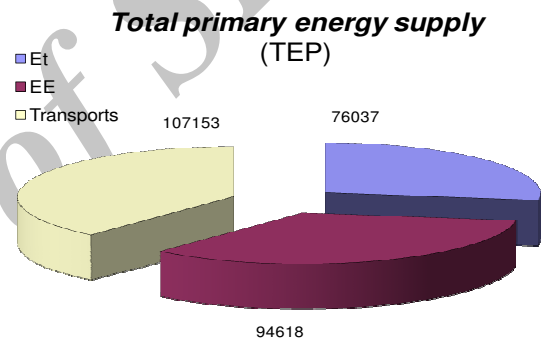

Fig. 3: Primary energy consumption of different sectors (present scenario)

Air emissions (t)	Present scenario
CO ₂	817612
CO	14100
CH ₄	9
N ₂ O	60
PM	109
NO _x	1172
VOC	1239
NH ₃	53
GWP20	863021
GWP100	864517
GWP500	856024

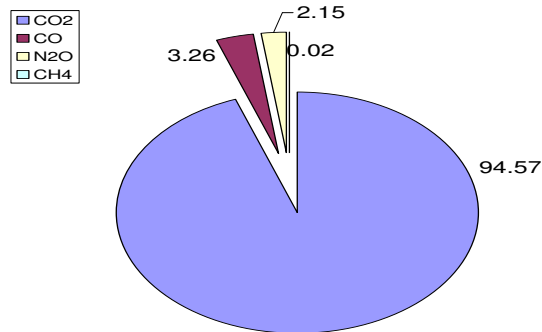

Fig. 4: Air emissions and GWP incidence

EE		ET		Transports	
Air emissions (t)	Present scenario	Air emissions (t)	Present scenario	Air emissions (t)	Present scenario
CO2	270600	CO2	151829	CO2	395184
CO	0	CO	332	CO	13768
CH4	0	CH4	9	CH4	0
N2O	0	N2O	10	N2O	50
PM	0	PM	19	PM	90
NOx	163	NOx	108	NOx	901
VOC	0	VOC	13	VOC	1226
NH3	0	NH3	0	NH3	53
GWP20	270600	GWP20	155651	GWP20	436771
GWP100	270600	GWP100	155639	GWP100	738277
GWP500	270600	GWP500	154175	GWP500	731251

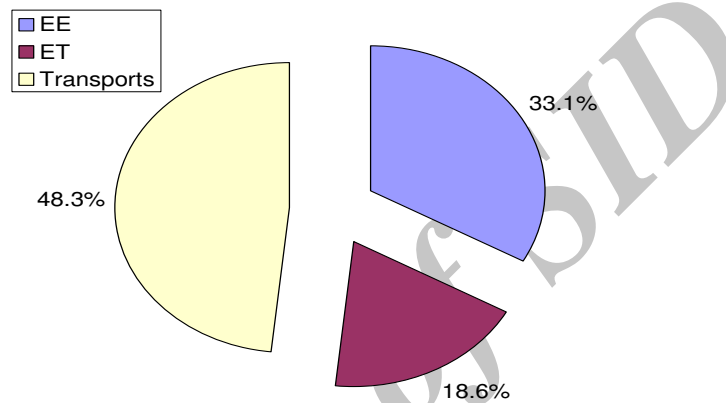

Fig. 5: Air emissions by sector and percentage of CO2 emis

It is possible to observe that transport applications and thermal energy generation cover more than 70% of the total CO2 emissions, thus clearly indicating that these are the areas where corrective actions would be more profitable.

9. Innovative Scenario

On the basis of the consideration performed in the previous paragraphs about the definition of the urban context chosen, it is now possible to present a new scenario, named innovative scenario, where clean energy vectors, namely hydrogen and electricity, are utilized, is analyzed. Hydrogen production by coal decarbonization will be investigated, as well as hydrogen use in advanced energy systems for transport and for thermal and electric energy generation. This new model has been carried out as follows (Fig. 6):

- a facility for the production of hydrogen-rich syngas from coal has been defined. The technology of coal gasification has been consi-

dered, followed by shift conversion reactions and by CO2 separation and liquefaction, in order to obtain a syngas rich in hydrogen. The syngas is distributed part to the centralized electric energy generation plant, part to the places equipped with fuel cells (PAFC) for distributed cogeneration, and finally to a hydrogen production facility, which, upon compression, is then utilized in public transport vehicles. This last section has been modeled in a rather straightforward way: suitable filtering systems (membranes) have been implemented in the model in order to obtain pure hydrogen from syngas. The remaining part of syngas, which still contains some combustible substances, as well as residual hydrogen, is burnt so as to extract useful thermal energy. In this work the energy requirements for the production and compression of hydrogen have been neglected. The syngas production facility releases some heat that is used for civil purposes in the district heating network;

- electric energy production is carried out in a power plant fueled by the syngas produced;
- thermal energy production, if not delivered by the abovementioned technologies, is carried out by means of boilers fueled only by natural gas;
- civil urban transport will be maintained exactly the same as in the present scenario; public transport, on the other hand, will be accomplished by means of PEMFC buses, fueled by pure hydrogen. This choice for the transport sector stems from the strong difficulties that, at least in a medium term scenario, are presented by the setup of a hydrogen distribution network easily accessible to all citizens, as well as from the hurdles that innovative technologies meet in an already mature sector such as the automotive industry, notwithstanding

the impressive efforts towards fuel cell vehicles production put in place by the major car companies. In the public transport sector, on the other hand, the transition to hydrogen as energy vector is certainly simpler because a centralized filling station can be used for all public vehicles, with a capital investment that, albeit onerous, is anyway affordable for big municipalized transport companies, which could also find support in the local governments, which could consequently enjoy a positive image feedback as well as facilitate the diffusion of hydrogen as energy vector in the private transport market.

As in the previous paragraph, the functional unit is the year.

More specifically, the input tables for the innovative scenario were built as follows.

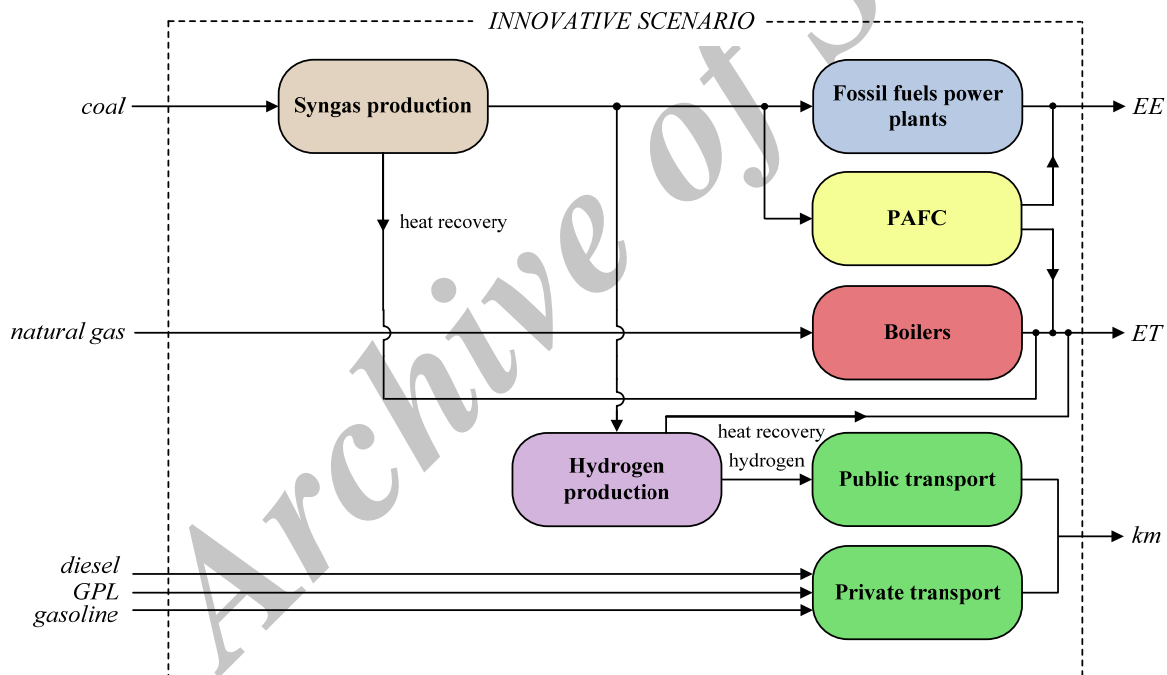

Fig. 6: Model of the innovative scenario

10. Syngas production facility

To produce hydrogen from coal, several steps have to be performed: the complete syngas production is shown in fig. 7 [16, 17]. Coal gasification permits transformation of a solid fuel into a gaseous one, by means of partial combustion

reactions. This process has been used for many years and today coal gasification is an interesting option for using coal – or low-grade fuels – with high efficiency (IGCC) and low environmental impact (NO_x, SO_x, particulate).

First, coal must be treated and prepared: in fact a gasifier is a chemical reactor where there are three inlet flows - coal, oxidizer and water (as liquid or steam) - and two output flows (syngas and slag). In a slagging gasifier, coal and water are mixed together to form the coal-water slurry. The main output flow is the syngas - composed mainly of CO and H₂ - while the second output flow is the so called slag, which is the solid residual of the combustion reactions. At gasifier exit, syngas is composed of CO and H₂ in the presence of steam and carbon dioxide.

To avoid CO₂ emissions from the power plants, it is necessary to produce a hydrogen-rich fuel gas. Thus the hydrogen output is increased via the water-gas shift reaction:

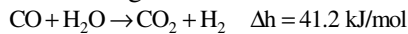

This reaction requires additional steam at proper pressure and temperature and it is favored at temperature of less than about 600°C and can take place as low as 200°C, with sufficiently active catalysts. In this phase a syngas cooling is necessary. Moreover, during shift reactions, other heat can be recovered.

The syngas, exiting the shift reactor section, is scrubbed to remove solids and soluble contaminants; it is cooled to very low temperature (about 25°C) with water release and it is purified to remove H₂S.

Now syngas, exiting the purification section, contains not only hydrogen but also a rather large quantity of carbon dioxide. This CO₂ can be considered as an impurity, so, before combustion in a power plant, it must be removed. If the gasifier is pressurized, CO₂ can be conveniently separated from the syngas by a physical process. This separation process (fig. 8) consists of two steps: absorption of CO₂ by a proper solvent, due to the selective solubility of CO₂ into the solvent at high pressure, and progressive recovery of CO₂ from the solvent by lowering pressure of the CO₂ rich solvent stream [17]. Carbon dioxide, released at various pressures, is re-compressed to the pressure of the first chamber and then ducted to a liquefaction section in order to sequestrate it as a liquid. The liquefaction process is performed in various steps by alternately compressing and cooling.

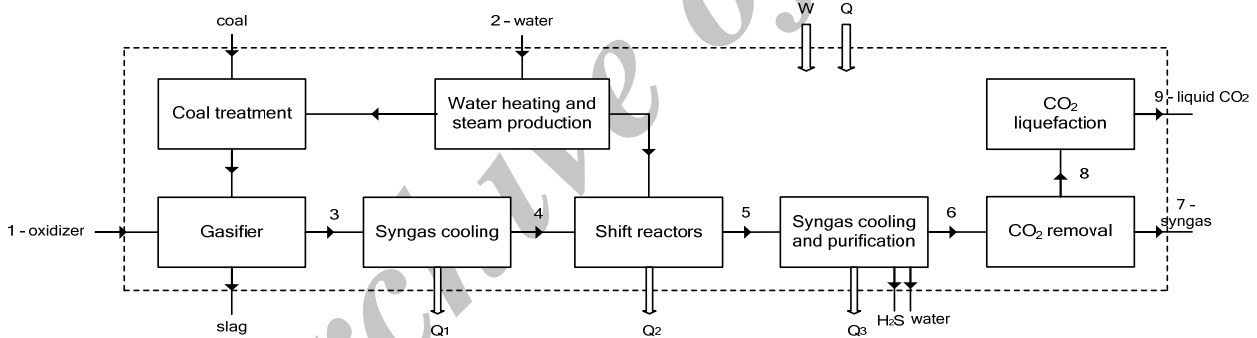

Fig. 7: Coal decarbonization process

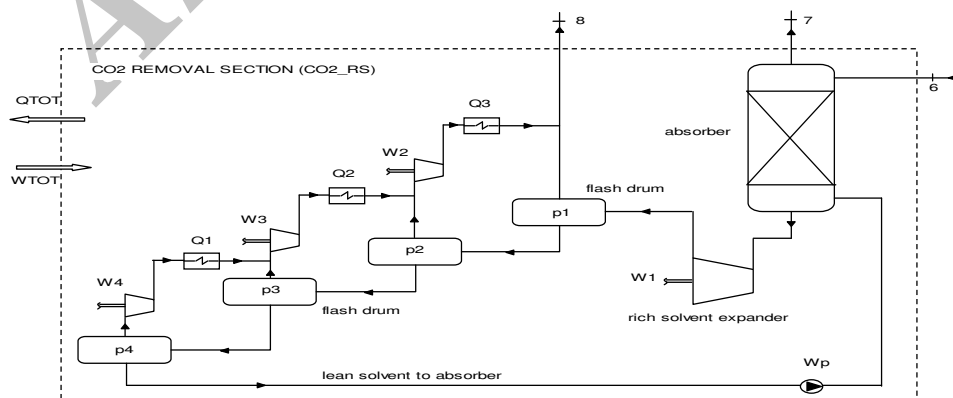

Fig. 8: Separation process of CO₂ by physical absorption

According to technical works [18-21], in this paper we will refer to an entrained-flow slurry-feed gasifier, reproducing Texaco technology. Coal used is Illinois #6, gasification pressure and temperature were assumed of 60 bars and 1600K. Oxygen supply and water/coal ratio were chosen according to the technical works mentioned above. On the basis of suitable assumptions, we have developed a numerical model, able to evaluate mass and composition of the main streams in the focal sections of the production plant (Table 4). Part of the raw syngas cooling can be profitably used: it can produce steam for the shift reactions. The slurry heating is carried out by using heat discharged by oxygen intercooled compression.

Once the heat and steam requirements of the decarbonization facility are satisfied, it is possible to utilize the remaining heat fluxes (Q3 and part of Q1 e Q2) in a district heating network. According to the previously presented data it is possible to recover up to 3150 kJ/kgcoal (that is 6833 kJ/kg syngas). All mechanical energy demands, for syngas production in all sections, will have to be satisfied by the electric energy production section (see later).

Based on these data, the input table necessary to describe the whole syngas production process could be assembled, with the reference unit "kgsyngas".

Table 4: Mass balance in coaldecarbonization section

Stream Properties												
point	T	p	m	% by vol.								
	(°C)	(bar)	(kg/kgcoal)	Ar	CH ₄	CO	CO ₂	H ₂	H ₂ O	H ₂ S	N ₂	O ₂
				40,00	16,00	28,00		2,00	18,00	34,00	28,00	32,00
1	300	62	0,837	0,00	0,00	0,00		0,00	0,00	0,00	5,00	95,00
2	15	1,013	1,139	0,00	0,00	0,00		0,00	100	0,00	0,00	0,00
3	1330	60	2,10	0,87	0,02	40,85	8,03	27,73	20,78	1,02	0,70	0,00
4	350	57	2,10	0,87	0,02	40,85	8,03	27,73	20,78	1,02	0,70	0,00
5	275	54	2,916	0,61	0,01	1,14	32,92	46,65	17,48	0,71	0,49	0,00
6	25	51	2,410	0,75	0,01	1,39	40,24	5,02	0,00	0,00	0,60	0,00
7	25	49	0,461	1,17	0,02	2,18	6,32	89,38	0,00	0,00	0,94	0,00
8	25	9,8	1,949	0,00	0,00	0,00	100	0,00	0,00	0,00	0,00	0,00
9	160	150	1,949	0,00	0,00	0,00	100	0,00	0,00	0,00	0,00	0,00

Mechanical energy requirements:	1922 kJ/Kg _{COAL}	
W _{GS}	248,3 kJ/Kg _{COAL}	Auxiliary power consumption, 1% of coal input
W _{CO2 RS}	88,30 kJ/Kg _{COAL}	P _{FLASH} : 10; 5; 2.5; 1.05 bars e=0.9
W _{CO2 LS}	438,4 kJ/Kg _{COAL}	Intercooled compression in two steps
W _{O2 ASU}	712,0 kJ/Kg _{COAL}	O ₂ Production (0.89 MJ/kg _{O2})
W _{O2}	435,0 kJ/Kg _{COAL}	intercooled compression in two steps

Heat fluxes for district heating network: 3150 kJ/kg_{COAL}

11. Distributed cogeneration with Phosphoric Acid Fuel Cells

Distributed cogeneration consists in the production of thermal and electric energy in small modular units, usually installed in direct proximity of the final utilization [22, 23]; electrical energy is prevalently absorbed on site, but the possible surplus can be sold and transferred to the external grid.

In this work Phosphoric Acid Fuel Cells (PAFC) have been considered for completely satisfying the energy needs of some facilities present in the urban context, namely three hospitals, three shopping malls and ten hotels.

PAFC are currently the more mature technology available on this specific market; they operate at

temperatures near 200°C, and therefore make a heat source available at such temperatures that make it possible to use it for the thermal energy needs; it has also been assumed that the plant be connected to the external grid so as to design its size according to the thermal energy needs, reverting to the external grid to exchange the deficit or surplus of electric energy locally generated. PAFC can operate with syngas but are not tolerant to CO: in this application the syngas produced in the previously described production facility has been used.

In order to assess the syngas consumption, it was assumed that the required hydrogen flow rate

is 64,73 kg/h/MWe, based on the operation of a 1,0 MWAC fuel cell stack with a cell voltage of 700 mV on pure hydrogen with a fuel utilization of 86% and an inverter efficiency of 96,5% [24]. The quantity of syngas has been calculated according to these data, and composition of the exhaust gases has been evaluated. It was assumed that only the hydrogen molecules change on the anode (fuel) side of the fuel cell. The other fuel gas constituents simply pass through to the anode exit. According to experimental tests reported in the technical literature, the ratio between thermal and electric energy production was assumed as 1 MWt/MWe. The thermal energy is recovered from the fuel cell cooling circuit and also from the exhaust gas utilization, which can be profitably exploited in a combustion process since it still contains some combustible substances. The input table of this process could therefore be built, with "MJe" as reference unit.

12. Hydrogen production facility

Based on the syngas obtained in the previously described facility, it is possible to devise a further separation process that could make pure hydrogen available for utilization in PEM fuel cells. This process, capable of producing hydrogen at convenient pressures, has been modeled in a rather simple way: a 95% separation efficiency has been considered in order to evaluate the quantity of syngas needed for the production of 1 kg of pure hydrogen. A ratio of 3,482 kgsyngas/kgH₂ was obtained. The remaining hydrogen-poor syngas stream was then burnt obtaining 2,60 MJt/kgsyngas of thermal energy. According to these data, both the syngas production process and the pure hydrogen production process could be modeled with an input table, where the "kgsyngas" and the "kgH₂" are the respective reference unit.

13. Electric energy production (by syngas)

An advanced combined cycle power plant was considered for the electric energy production based on syngas, with a three pressure level HRSG and steam reheating. In order to assess the syngas consumption and to define the related emissions, the average efficiency of this combined cycle power plant operated in Italy (whose

value is about 52,0%), has been considered. Such efficiency could be theoretically improved in a modern advanced power plant, but this level is suitable for taking into account both the seasonal operation, with variable loads and climatic conditions, and the mechanical energy required to compress the syngas at pressure levels adequate for the gas turbine operation [16]. The input table of the power plant has been drawn up, considering the typical emissions from such plants, with reference only to CO₂ and NO_x; NO_x emissions, in particular, have been assumed equal to those of a traditional combined cycle power plant [7-9]. The reference unit for this input table is the "MJe".

14. Hydrogen-based public transport

Public transport in the innovative scenario considered is based on hydrogen-fueled buses. In this work, the data concerning vehicles powered by Proton Exchange Membrane Fuel Cells (PEMFC) were drawn by the field experience of such buses in the city of Turin, where they are operated since November 2004 [25]. The CityClass buses, manufactured by Irisbus, are designed according to a hybrid configuration, where the primary energy source is the fuel cell, which feeds the battery pack (by means of a step-up converter) that, in turn, powers the electric engine. The bus is powered by PEMFC developed by the company UTC fuel cells, fed by pure hydrogen. The hydrogen consumption resulting from the field tests is of approximately 100 gH₂/km. Its emissions are made up of water vapor only. The reference unit for the corresponding input table is the "km•vehicle".

The energy requirements of the operations involved, taking into account the alternative solutions proposed, must be assessed. Some of the already considered facilities have been made at least partially self-sufficient in the innovative scenario. Therefore the first step of the scenario analysis is represented by the dimensioning of the distributed cogeneration plants.

The facilities where the installation of PAFC (devoted to the distributed cogeneration) has been considered are the following:

- the three hospitals;
- the three shopping malls

- the ten hotels.

The size of the PAFC has been determined on the basis of the thermal energy requirements. The corresponding electric energy production results from the characteristics of the PAFC plant, and it may or may not be sufficient for the facility needs. Therefore these systems are considered to be connected to the external grid in order to be able to define an annual net balance of the energy flows between the PAFC and the grid. The size of each microgeneration plant has therefore been defined according to the maximum daily thermal requirement of each facility, taking into account the annual energy needs already evaluated in the preceding sections. Two typical days are considered, one during summer and the other during winter. The daily loads, described in Fig. 9, have

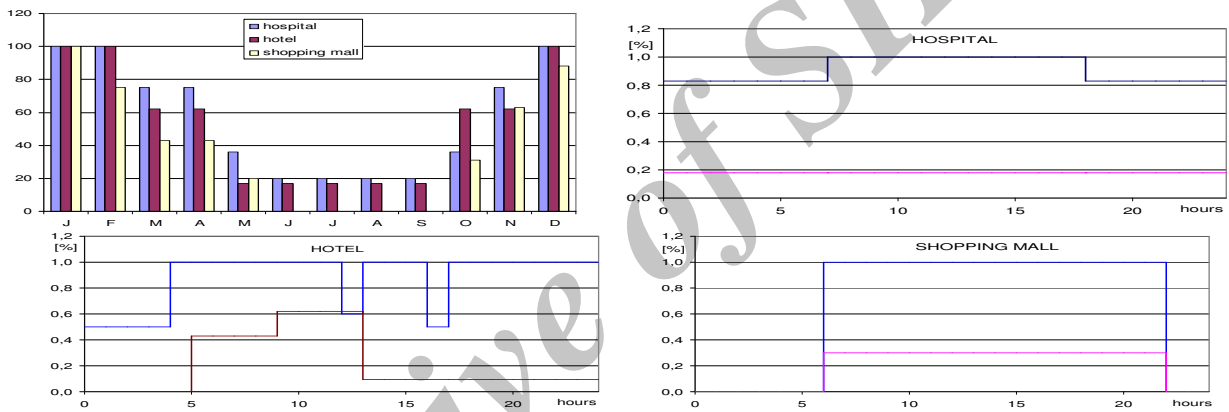

Fig. 9: Monthly and daily loads

Table 5: Size and energy production of PAFC

	Hospitals	Hotels	Shopping malls
Pnom [MW]	3,5/1,8/0,57	0,64 (each)	1 (each)
EE [MWh/y]	15841/7921/2560	25205	6732
ET [MWh/y]	15841/7921/2560	25205	6732
EE needs [MWh/y]	4547/2829/914	4600	17028
Syngas [t/y]	3391/1696/548	5395	1441

In the innovative scenario, urban transport is operated by means of hydrogen-fueled buses. These vehicles have a hydrogen consumption of 100 gH₂/km. Since the distance traveled is 2500•10³ km, the syngas consumption for public transport purposes is 870,5 t/y.

At this point it is possible to determine the size of the syngas-fueled electric power plant. The electric energy balance, in fact, must consider both the energy needs of the urban context and the energy required by the syngas production

been integrated so as to determine the daily thermal energy consumption. According to this value, the fuel cell nominal power is evaluated; it is used to satisfy the thermal energy needs all year long. The electric and thermal energy production is then evaluated for each month of the year, taking into account the ratio Pe/Pt previously introduced. Efficiency of PAFC fuel cells is constant down to a 40% load, and it is yet not significantly reduced at 30% load. Therefore, in all applications PAFC efficiency has been assumed constant with respect to the load; the syngas consumption has been evaluated on the basis of this constant level. According to the previous considerations the size of these facilities has been determined and reported in Table 5.

process; the electric energy produced by the distributed cogeneration plants must also be duly considered in the overall balance, which can be expressed as follows:

$$EE_{TOT} + EE_{aux} \cdot m_{syn_tot} - EE_{PAFC} = EE_{CC}$$

$$EE_{TOT} + EE_{aux} \cdot m_{syn_tot} - EE_{PAFC} = \bar{\eta} \cdot m_{syn_CC} \cdot H_{i_syn}$$

where:

EE_{TOT}: electric energy needs of the city;

EE_{aux}: electric energy required by the syngas

- production facility;
- EE_{PAFC} : electric energy production by the distributed cogeneration plants;
- EE_{CC} : electric energy production by the syngas-fueled combined cycle power plant;
- m_{syn_CC} : syngas annually consumed by the syngas-fueled power plant;
- m_{syn_tot} : total quantity of syngas annually consumed (by the power plant, microcogeneration facilities and public transport);
- $\bar{\eta}$: is the global efficiency of the syngas-fueled facility for the electricity production.

By means of the preceding expression, it is possible to calculate the annual consumption of syngas as 121275 t/y.

The thermal energy requirements are reduced

with respect to the present scenario because some of the facilities have been made self-sufficient, and also because it is possible to recover some of the heat flux from the syngas production facility. The thermal energy needs of the urban context amount to 2488 TJ/year, having deduced the energy needed by the facilities where distributed cogeneration plants have been installed. The syngas production facility allows to recover 828,7 TJ/year and from the hydrogen production facility 2,263 TJ/year can be recovered. Such heat fluxes, distributed through a district heating network, cover approximately 55% of total thermal residential energy consumption. The remaining 1658 TJ/year is considered to be supplied by natural gas boilers.

As far as private transport is concerned, the same remarks as in the present scenario hold true.

The new scenario is shown in Fig. 10.

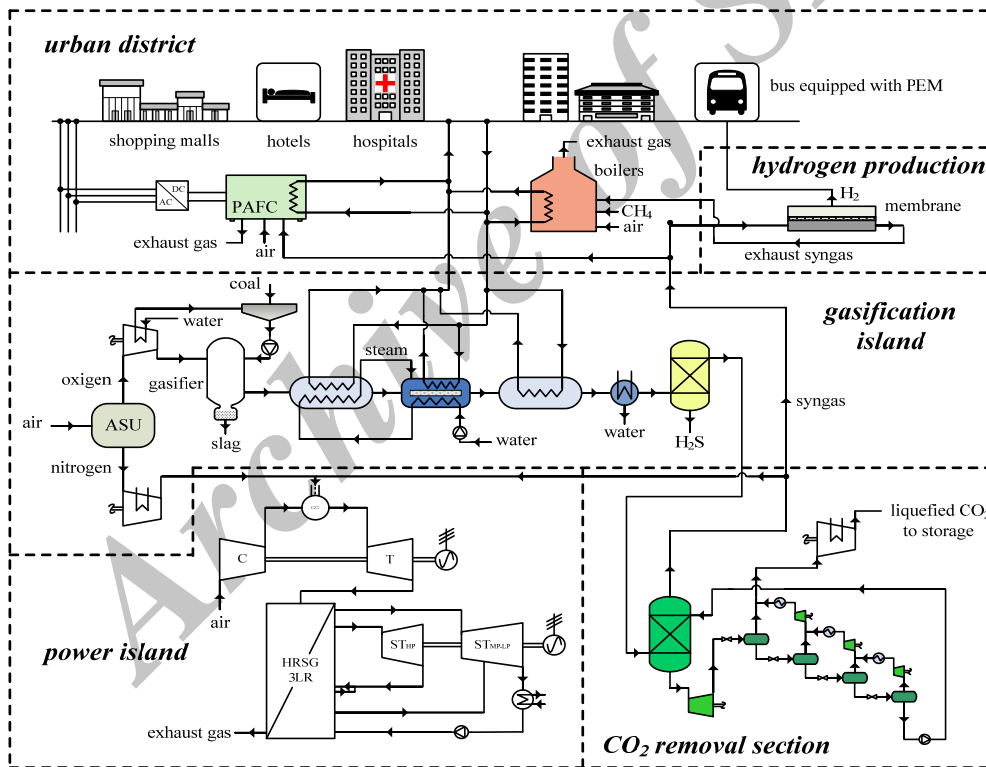

Fig. 10: Innovative scenario

15. Energy consumption assessment and emissions in the innovative scenario

At this point it is possible to quantify the main primary energy sources consumption and the relative importance of each source on the different

consumption sectors (Fig. 11-12). It is possible to observe that coal plays an even larger role in this case than in the present scenario (over 50% of total primary energy consumption), gasoline, nat-

ural gas and diesel oil represent respectively 21%, 15% and 13% of total energy consumption, and also in this case LPG plays a minor role. Electric energy production facilities, including the micro-cogeneration plants, require the most part of the primary energy sources (50% of total); the transport sector follows with a consumption of 35% of primary energy sources, and finally thermal energy needs (15% of primary energy sources) in this scenario are positively affected by the heat recover from the syngas and hydrogen production facilities.

In what follows the annual greenhouse gas emissions (CO₂, CO, CH₄, and N₂O), other air emissions (NO_x, NH₃, VOC and PM) and the GWP are presented.

Fig. 13 shows the total emissions in this second, innovative, scenario. Carbon dioxide is obviously still the most relevant emission, and for the other gases the same classification is valid.

The human activities that are responsible for greenhouse gas emissions are the same as in the previously considered scenario, but they are more interconnected. Distributed cogeneration, for instance, can be classified as both electric and thermal energy generation, and it is useful to remind that syngas production contributes to meet the city thermal energy requirements. Therefore, in this new scenario, emissions related to syngas production, electric energy generation by syngas-fueled power plants and distributed cogeneration plants are entirely ascribed to electric energy generation, while emissions related to hydrogen production facility are entirely ascribed to transport applications, although it also contributes, as it was earlier pointed out, to the thermal energy needs.

Fig. 13 indicates total emissions, classified based on electric or thermal energy generation or transport applications, and it also gives the percentage of total CO₂ emissions for the same three sectors. It is possible to notice that in this case transport applications have a very high impact on CO₂ emissions, for they alone are responsible for about 70% of the emissions; the contribution of electric and thermal generation is practically equivalent (13.6% and 16.4% respectively).

The comparison between the two scenarios considered (Fig. 14) shows that CO₂ emissions are the most (positively) affected by the modifications introduced in the second scenario, but also CH₄, which is mainly correlated with boiler operation, is significantly reduced. In the innovative scenario, by resorting to a great extent to cogeneration plants and district heating networks, this pollutant emission is much less important. NO_x emissions are also reduced since in the innovative scenario boiler utilization is greatly reduced, and electric energy is generated with higher efficiencies. Similar remarks are valid for N₂O and PM, as far as boiler operation is concerned. GWP is reduced by about 30% in all the timeframes considered, while other emissions are not significantly affected.

Analyzing more specifically each pollutant emission based on the relative emission activity, it is possible to observe (Fig. 15) that transport applications certainly have the lion's share on each pollutant, and this situation is not altered even in the innovative scenario, where only public transport is operated with hydrogen-fueled vehicles.

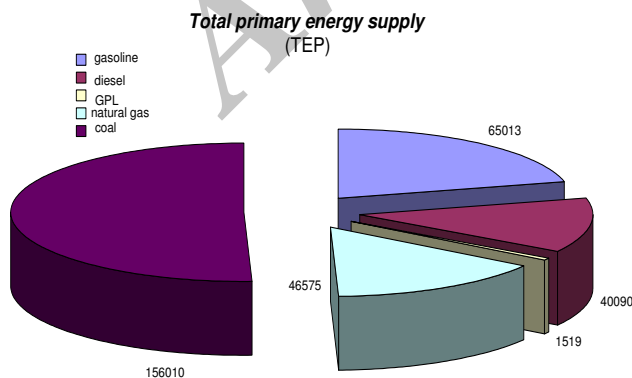

Fig. 11: Primary energy sources consumption

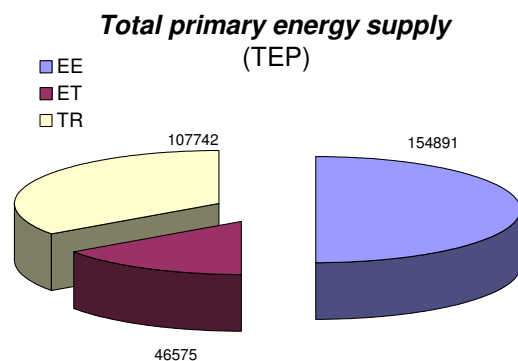

Fig. 12: Primary energy consumption of different sectors (innovative scenario)

Total		EE		ET		Transports	
Air emissions (t)	Present scenario	Air emissions (t)	Present scenario	Air emissions (t)	Present scenario	Air emissions (t)	Present scenario
CO2	561160	CO2	76332	CO2	91925	CO2	392903
CO	13968	CO	0	CO	214	CO	13754
CH4	5	CH4	0	CH4	5	CH4	0
N2O	55	N2O	0	N2O	5	N2O	50
PM	99	PM	0	PM	11	PM	88
NOx	924	NOx	0	NOx	65	NOx	856
VOC	1230	VOC	0	VOC	8	VOC	1222
NH3	53	NH3	0	NH3	0	NH3	53
GWP20	604795	GWP20	0	GWP20	94023	GWP20	434440
GWP100	606273	GWP100	0	GWP100	93998	GWP100	435943
GWP500	598490	GWP500	0	GWP500	93230	GWP500	428928

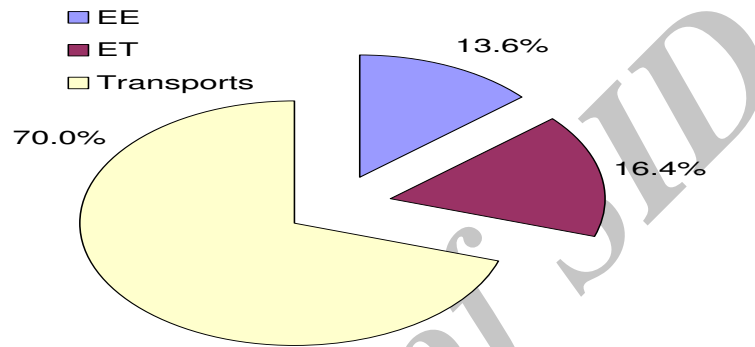

Fig. 13: Air emissions (innovative scenario) by sector and percentage of CO2 emission



Fig. 14: Final comparisons in terms of global emissions

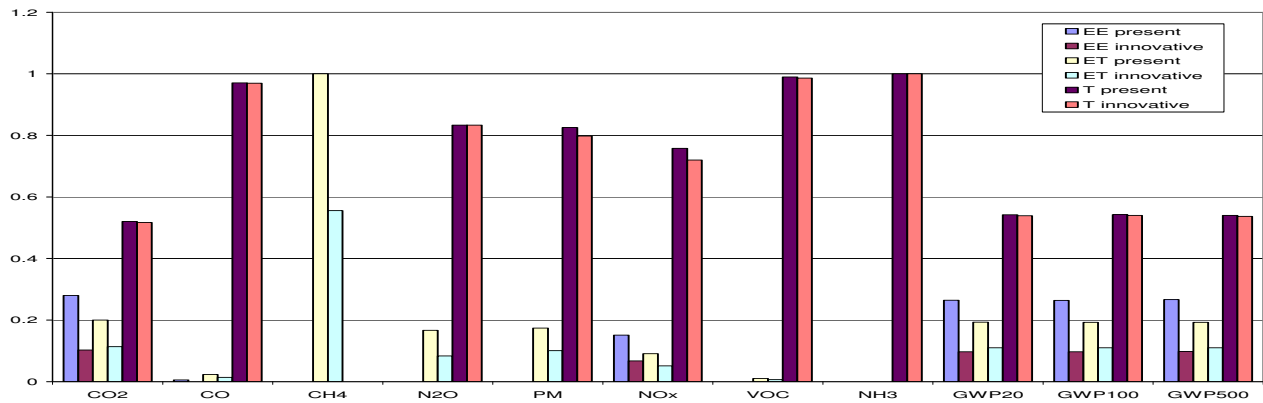

Fig. 15: Final comparisons in terms of global emissions by sector

The incidence of the corrective actions undertaken on transport sector is therefore marginal. CO, VOC, NH₃ and N₂O emissions are indeed practically the same as in the present scenario, since they are mainly generated by road traffic.

Carbon dioxide emissions, on the other hand, are reduced by approximately $256 \cdot 10^3$ t, but primary energy consumption is increased by 31398 toe. Considering the typical cost of coal (2,0 €/GJ), it is possible to quantify in monetary terms this primary energy surplus, which is required to reduce carbon dioxide emissions: the result is that in the innovative scenario CO₂ reduction cost 10 €/t (it is worth to remind that in the framework of the actual Emission Trading scheme, CO₂ prices are approximately quoted at 15-30 €/t for the second period, 2008-2012, [26]). Furthermore, it should be noted that in this preliminary economic assessment all costs related to the implementation of the new plants in the innovative scenario have been neglected. However, this result seems very encouraging. There is therefore a need of a more in-depth economic analysis so as to take into account many different issues that are to be considered in setting up a new energy scenario for small- and medium-size towns (such as, for instance, all fuel mining and transport operations, as well as building new plants or retrofitting old ones); however, it seems already manifest that, in order to cope with environmental issues in urban contexts in the medium and long term, it is of the utmost importance to undertake thorough actions in the transport sector, identifying global strategies and specific measures so as to meet the mobility needs while, on the same time, drastically

reducing pollutant emissions. Failing to introduce such actions, the emission reductions that are possible to achieve are somewhat limited.

16. Conclusion

In this work energy and environmental analysis of a typical central Italy urban context (approximately 90000 inhabitants) has been presented. The goal of this analysis was to define a possible alternative energy scenario to the present one, in order to achieve significant reductions of its environmental impact, which has been evaluated in terms of greenhouse gas emissions and even other, non-greenhouse pollutant emissions (NO_x, VOC, PM, NH₃).

The definition of an alternative scenario has been focused on a partial utilization of hydrogen, produced by coal gasification, with CO₂ sequestration and liquefaction. The obtained syngas is partly sent to a central combined cycle power-plant, partly to microgeneration systems based on PAFC fuel cells, and the remaining part to a facility for the production of pure hydrogen that is then used on public transport vehicles.

The results obtained indicate that significant reductions of CO₂ can be achieved, with a GWP that is reduced by 30% with respect to the present scenario.

Total carbon dioxide emissions is reduced by 31.3%, but overall primary energy consumption increases by approximately 11.3%, resulting in a cost of 10 € for each ton of carbon dioxide not emitted. The economic result is very interesting. As it was easily foreseen, the results show that transport applications are the main responsible for

pollutant emissions both in the present and in the innovative scenario, since private transport is the same (in the innovative scenario only public transport is hydrogen-fueled, hence the marginal impact of the modifications in this scenario on the overall transport sector).

There is therefore a need of a more in-depth economic analysis so as to take into account many different issues that are to be considered in setting up a new energy scenario for small- and medium-size towns; however, it seems already manifest that, in order to cope with environmental issues in urban contexts in the medium and long term, it is of the utmost importance to undertake thorough actions in the transport sector, identifying global strategies and specific measures so as to meet the mobility needs while, on the same time, drastically reducing pollutant emissions. Failing to introduce such actions, the emission reductions, which are possible to achieve by means of the modification to the energy scenario proposed in this work, are somewhat limited and highly onerous from the economic point of view.

References

- [1] Provincia di Pisa, "Programma energetico provinciale". Pianificazione energetica. (in italian)
- [2] Comune di Pisa – Assessorato all'Ambiente "Rapporto sullo stato dell'ambiente nel comune di Pisa" (in italian) http://www.comune.pisa.it/ambiente/pdf/RSA_2004.pdf
- [3] Comune di Pisa – Assessorato all'Ambiente "Rapporto sullo stato dell'ambiente nel comune di Pisa" (in italian) http://www.comune.pisa.it/ambiente/pdf/RSA_2006.pdf
- [4] <http://www.aci.it>
- [5] Relazione Finanziaria Annuale, Terna S.P.A. e Gruppo Terna, 2007, <http://www.terna.it/> (in italian)
- [6] <http://www.terna.it/> Sistema Elettrico, Dati Statistici (in italian)
- [7] E. Macchi, "Cicli combinati a gas naturale", Polipress – Politecnico di Milano, 2005.
- [8] G. Cau, D. Cocco, "L'impatto ambientale dei sistemi energetici", SGE, Padova, 2004.
- [9] C. Caputo, "L'impatto delle macchine sull'ambiente", Masson, Milano, 1998.
- [10] <http://www.sinanet.apat.it/it>
- [11] <http://www.cpt.pisa.it/info/autobus.htm>
- [12] Macchi, S. Campanari, P. Silva, "La microcogenerazione a gas naturale", Polipress – Politecnico di Milano, 2005.
- [13] Satoru Okamoto, "Saving energy in a hospital utilizing CCHP technology", International Journal of Energy and Environmental Engineering, Volume 2, Issue 2, 30 Jun 2011
- [14] Protezione Internazionale dell'Ambiente, "I meccanismi flessibili del Protocollo di Kyoto", Ministero dell'Ambiente e della Tutela del Territorio e del Mare.
- [15] IPCC, "Third Assessment Report: Climate Change 2001".
- [16] Gambini M., Vellini M; 2005, "Overall performance of advanced H₂/air cycle power plants based on coal decarbonization", Proceedings of ASME Power 2005, April 5-7, Chicago, Illinois, USA, ASME Paper PWR2005-50117
- [17] Gambini M., Vellini M; 2007, "Performance optimization of advanced power plants based on fossil fuel decarbonization technologies", Proceedings of ASME Power 2007, July 17-19, San Antonio, Texas, USA, ASME Paper PWR2007-22025
- [18] Chiesa P., Lozza G., 1998, "CO₂ emission abatement in IGCC power plants by semi-closed Cycles. Part B: with air-blown combustion and CO₂ physical absorption", Proceedings of ASME TURBO EXPO 1998, Stockholm, Sweden
- [19] Chiesa P., Consonni S., 1999, "Shift reactors and physical absorption for low-CO₂ emission in IGCCs", Journal of Engineering for Gas Turbine and Power, Vol.121, April 1999.
- [20] Chiesa P., Consonni S., Kreutz T., Williams R., 2005, "Co-production of hydrogen, electricity and CO₂ from coal with commercially ready technology. Part A: performance and emissions" International Journal of Hydrogen Energy, 30, pp. 747-767
- [21] Chiesa P., Consonni S., Kreutz T., Williams R., 2005, "Co-production of hydrogen, electricity and CO₂ from coal with commercially ready technology. Part B: Economic analysis"

International Journal of Hydrogen Energy, 30, pp. 769-784

- [22] Mohsen Rezasoltani , Roozbeh Zomorodian , Mohammad Bagher Ghofran, "A new approach to optimization of cogeneration systems using genetic algorithm", International Journal of Energy and Environmental Engineering, Volume 1, Issue 1, 23 Dec 2010
- [23] Roozbeh Zomorodian , Mohsen Rezasoltani , Mohammad Bagher Ghofrani, "Static and dynamic neural networks for simulation and optimization of cogeneration systems", International Journal of Energy and Environmental Engineering, Volume 2, Issue 1, 28 Mar 2011
- [24] U.S. Department of Energy, Office of Fossil Energy, National Energy Technology Laboratory, "Fuel Cell Handbook (Seventh Edition)", November 2004
- [25] <http://www.automobileidrogeno.com/mod09.htm>
- [26] E. Russo, Enel, April 2008, "Emission Trading: working logic of the market. Threats and opportunities" (in Italian)

Biographies



Marco Gambini Full Professor of "Energy Systems " at the University of Rome "Tor Vergata". His research is addressed to conventional steam and gas turbine based power plants, advanced power plants based on combined and mixed gas-steam cycles and diagnostic and monitoring systems for power plants and their components. Other key research areas are the repowering of existing thermoelectric and cogeneration power plants, optimisation of energy use in industrial processes and reduction of carbon dioxide emissions from fossil fuel power plants. In 2001 he received the Prime Movers Award from the Power Division of the ASME for the paper titled "CO₂ Emission Abatement from Fossil Fuel Power Plants by Exhaust Gas Treatment" presented at the 2000 International Joint Power Generation Conference



Michela Vellini Associate Professor of "Energy Systems " at the University of Rome "Tor Vergata". Her research is addressed to conventional steam and gas turbine based power plants, advanced power plants based on combined and mixed gas-steam cycles, cogeneration power plants, reduction of carbon dioxide emissions from fossil fuel power plants and optimisation of energy use in industrial processes. In 2001 she received the Prime Movers Award from the Power Division of the ASME for the paper titled "CO₂ Emission Abatement from Fossil Fuel Power Plants by Exhaust Gas Treatment" presented at the 2000 International Joint Power Generation Conference.