

Compressed air energy storage system based engine for running light vehicle

Bharat Raj Singh¹ and Onkar Singh²

¹Associate Director and Professor & Head of Department-Mechanical Engineering, School of Management Sciences, Technical Campus Lucknow-227125, Uttar Pradesh, India

²Professor and Head of Department-Mechanical Engineering, Harcourt Butler Technological Institute, Nawabganj, Kanpur-208002, Uttar Pradesh, India

Received: 26 July, 2011

Accepted: 31 Oct. 2011

ABSTRACT

Globally excessive consumption of hydrocarbon fuel in transport sector is a serious threat to the civilization due to the paucity of fuel in future. Also this growing use of vehicles for transport is contributing about 70% of total air pollution and causing environmental and ecological imbalances. Thus the worldwide fast depletion of conventional energy resources and impact of emissions on environment necessitates the search of alternative non-conventional energy sources, and other direct energy conversion systems. This paper deals with the study of sustainable renewable energy resources and their conversion system. Air has been considered as a sustainable renewable energy resource and an emission free compressed air driven engine has been analyzed for better and sustainable energy future in this paper. Here parametric study of a vane type novel air turbine is carried out for arriving at optimal turbine specifications and operating conditions. The optimum power output obtained ranges from: 1.0 kW, 4.0 kW and 9.0 kW at $D=50$ mm, 100 mm and 150 mm respectively, when rotor/ casing ratio (d/D) = 0.70, vane angle (θ) is kept 30° to 45° (vanes =12 to 8 nos.), and other parameters such as: injection angle (60°), injection pressure (6 bar) and speed of rotation (2500rpm) are kept constant throughout the study.

Keywords

fossil fuel, pollution, emission, depletion, energy source, energy conversion.

1. Introduction

Worldwide depletion of conventional energy resources [1, 2], necessitates the search of alternatives resources such as: non-conventional and renewable energy sources, for sustainable future energy sources. India is a developing country and average income per person is very low to meet out the minimum requirement of person. Maximum population of country is still living in villages where transport is either bicycle or motorbike. Current hike rate of fossil fuel prices up to 30-40 % every year has made the situation alarming. With this pace by 2010 prices may go double than what is today and by 2030-40, it may touch to Rs.1000 per litre. A time will come when common person would not be able to purchase

fuel to run the motorbike. It is not only due to rate of increase of vehicles in India, but it is a worldwide problem as 80 % of fossil fuel being consumed in transport with increasing mobility of persons and transportation of daily consumable materials through road transport. Thus, the need of the day is to explore possibility of alternatives for fossil fuel to make environment free from emission and make children healthy.

It is also seen that researches were carried out on multi vane expander for its various parameters such as: geometry, end friction, optimizing the efficiency [3-12] and pneumatic hybrid power system [13-16]. The work of pressure regulation of turbine, performance efficiency of Rankine

*Corresponding author: Bharat Raj Singh (e-mail brsinghko@yahoo.com)

cycle, multi-stage turbine compressor models, experimental investigation on rotary vane expander, three-stage expander into a CO₂ refrigeration system, endface friction of the revolving vane mechanism, and design and implementation of an air-powered motorcycle have also been studied [17-23]. This paper deals with study of renewable/non-conventional energy to maintain energy sustainability in 21st century and utilizing compressed air as an attractive alternative for the development of emission free engine, which can lead to better future both environmentally and ecologically. For this a compressed air driven novel air turbine has been considered and parametric evaluation done for arriving at optimal specifications of casing to rotor dimensions and operating conditions.

2. Literature Review

In general terminology, sustainability can be stated as; meeting the needs of current and future mankind/generations through simultaneous environmental, social and economic improvements [24], whereas sustainability of the energy resource is to preserve the oil and make brighter future of mankind by adding alternative energy sources such as: non-conventional and or renewable energy which is going to help current problem to some extent. Now worldwide researchers/inventors are paying full attention towards this issue. It is also learnt that there are two distinct reasons for search of alternative to fossil fuel and make sustainable energy source; the first one is depletion of oil resources which is causing civilization vulnerable, thereby many researchers, technologists and scientist have spoken [25, 26] as to why alternative to fossil fuel is required and other one is higher rate of emission due to rapid use of hydrocarbon fuel.

The study on efforts made for reducing the pollution have also been done related to dual fuel systems such as: effect of exhaust gas recirculation (EGR) on combustion and pollution of dual fuel engines [27], partial substitution of diesel fuel by natural gas [28], using for maldehyde as an additive on the performance of an homogeneous charge compression ignition (HCCI) engine fueled with natural gas [29].

2.1 Alternatives to Energy Resources

Many researches are being carried out to find the alternative to fossil fuel. Apart from them non-conventional energy such as windmill operated devices, bio-diesel and di-methyl ether, hydrogen cell, photovoltaic cell, battery operated vehicles are being used as an alternative to fossil fuel.

2.1.1 Use of Wind Energy: Windmills are being used very effectively for irrigation as well as power generation, where high velocity air is running in atmosphere, due to geological conditions. Wind power is the kinetic energy of wind, or the extraction of this energy by wind turbines. In 2004, wind farm power became the least expensive form of new power generation, dipping below the cost per kilowatt-hour of coal-fired plants. Wind power is growing faster than any other form of electrical generation, at about 37%, up from 25% growth in 2002. In the late-1990s, the cost of wind power was about five times than its cost in 2005. The downward trend is expected to continue due to mass production of multi-megawatt turbines.

2.2 Energy Conversion and Storage Systems

There are many energy conversion systems which are in practice for utilizing energy whenever there is a disruption in regular supply, which is listed [30] as follows:

2.2.1 Super Capacitor: Electrochemical capacitors (EC) store electrical energy in the two series capacitors of the electric double layer (EDL), which is formed between each of the electrodes and the electrolyte ions. The distance over which the charge separation occurs is just a few angstroms. The capacitance and energy density of these devices is thousands of times larger than electrolytic capacitors. The asymmetrical capacitors that use metal for one of the electrodes have a significantly larger energy density than the symmetric ones and have lower leakage current. The asymmetrical capacitors that use metal for one of the electrodes have a significantly larger energy density than the symmetric ones and have lower leakage current.

2.2.2 Flywheels: Most modern flywheel energy

storage systems consist of a massive rotating cylinder (comprised of a rim attached to a shaft) that is substantially supported on a stator by magnetically levitated bearings that eliminate bearing wear and increase system life. To maintain efficiency, the flywheel system is operated in a low vacuum environment to reduce drag. The flywheel is connected to a motor / generator mounted onto the stator that, through some power electronics interact with the utility grid. Some of the key features of flywheels are little maintenance, long life (20 years or 10s of thousands of deep cycles) and environmentally inert material. The stored energy can be approximated by:

$$E = (I\omega^2) / 2 = (mr^2\omega^2) / 2 = (mv^2) / 2$$

where ω is the rotational velocity (rad /sec), I is the moment of inertia for the thin rim cylinder, m is the cylinder mass and v is linear rim velocity.

2.2.3 Compressed Air Storage System: The air engine technology is very old and was in process of development parallel to combustion technology. It is on record that Sterling air engine was developed in 1790-1810, but due to some limitations much work was not carried out. The uses of such engines are limited such as in Coalmines where fire problem are predominant and other high flammable places where fossil fuel vehicles are not advisable to be utilized. The technology again took its rolling pace in 1979 when cost of petroleum product had gone very high, but from 1979 to 1998 much work did not take place. Since the last two decades lot of researches are being made to tap down air freely available in atmosphere and compressing it for storage in cylinders for its further use. This compressed air can be used to run combustion engine with mixture of gas and air getting fired at compression stroke at TDC. Compressed air helps for fire stroke when ignition takes place. Thus efficiency of IC engine gets improved and without running all four stroke cycle it runs on two stroke cycles. The air engines so far developed are basically running on hybrid such as compressed air and gases and are not 100% zero pollution.

3. Compressed air as an alternative to fossil fuel

Compressed air can be suitably used as working fluid for running air engines and has many advantages being emission free and environment friendly.

3.1 Availability of Air

Air is natural source and available freely in atmosphere, which can be stored after compressing it to desired pressure such as 90- 350 psi. This is the only source, which can be stored at very high pressure and can be retained without any loss after lapse or with passage of time. Compressed air can drive many domestic appliances such as vacuum cleaner, mixers, pumps, electric generator when electric power fails instead of using inverter to have clumsy arrangements of battery, etc.

3.2 Sustainability, Economics and Advantages

Compressed air is most sustainable. It has no volatility or temperature or much weather effect. Once compressed air is stored through compressor, it will be available at any time without any loss of pressure. Thus sustainability of compressed air is much better compared to other available alternate of fossil fuel. Battery needs constant maintenance even for charging and discharging cycle. Hydrogen Cell is very costly due to its storage problems. Wind Mills, Photo Cells also need some storage devices may be of high bank capacitors or batteries, which will need constant and recurring expenditures on its upkeep.

3.3 Influences on Environment and Ecology

Compressed air as an alternate for running light vehicles using air turbine will have no ill effect on ecology and reduce the health hazards due to the vehicles. Emissions at the power plants generating electricity required for running compressors to get compressed air can be suitably controlled. Thus overall pollution due to these compressed air vehicles will be less than existing fossil fuel-based systems.

3.4 Cost Comparison

In case the compressed air is being used in place of fossil fuel, the air is freely available in atmosphere and offers zero cost of basic working fluid and the cost involvement in its compression is also nominal. The costing analysis for the vaned air turbine based engine under study is as-detailed below;

- Cost of 10 to 15 HP electric motor coupled with 2-3 stage compressors: Rs. 25,000.00
- Cost of electricity for filling the compressed air cylinder once*: Rs. 5.00 to Rs. 7.00
- Consumption of electric power for running it for 5-10** min to fill the cylinder of 1.2 m long and 0.65 m dia at 15-20 bar (225 – 300 psi) may cost {(10 kwh X Rs 4.00# to 5.00#). (60 min / 8 min**average) = (Rs.5.00 to 7.00)} including depreciation, running and maintenance of compressor devices.

- Cost of electricity per unit in Rupees]

- Once cylinder is filled with compressed air, it can run vehicle up to 40 km.
- Cost of running vehicle per km using compressed air: Re. 0.12 to Rs. 0.17
- The present cost of running vehicle per km using hydrocarbon fuel : Re. 0.62 to Rs. 0.75

This shows that the motor bike may run 40 km in Rs.5.00 to Rs. 7.00, whereas cost of same travel distance with hydrocarbon fuel may be around Rs. 25.00 to Rs.30.00 and hence compressed air cost is almost one fifth of fossil fuel cost. On the other hand, in the absence of fossil fuel combustion, air as working fluid offers advantage of giving zero pollution engines. Thus the use of compressed air is economical too apart from being environmental friendly.

3.5 Advantages/Disadvantages of Air Engine Compared to the Electric Motors

Air engines are having much of advantages as compared to the electric motors such as: it can easily be used in volatile atmospheres, deliver more power that of same size of electric motor, operate without any type of auxiliary speed reducers, cause no harm on overloads, torque pro-

duced is controlled by simple flow control by means of valves by regulating the pressure, generate very less heat. The only drawback is noticed that the torque produced by the air engines suffers in a great way; when the flow of air or the pressure gets disturbed.

4. Development of compressed air engine

There is need of devising an efficient compressed air engine so that maximum specific power could be produced. Such compressed air engine will have requirement of compressors for producing compressed air as working fluid. Thus there are two issues, one for developing an efficient compressed air engine and other one to have efficient compressor and air storage system. In this area development of air engines are being made very fast. Some of the works developed so far are given as bellow:

- A French Scientist Guy Negre, in 1998 developed compressed air 4- cylinders engine run on air and gasoline, claims zero pollution cars and got 52 - patents registered since 1998 to 2004. The car was publically demonstrated in Oct.'2004 [31].
- A Canadian inventor G. Saint-Hilaire, developed zero pollution cars using Quasiturbine with a set of 14-engines parameters and disclosed on Sept' 2005 using gasoline [32].
- Indian duo Scientists studied the various aspects of efficiency improvements of wind turbine, tip speed ratio etc.[33-36] and developed an air turbine engine in 2010, which can be utilized as prime-mover to light vehicle or motor-bike efficiently[37-45] on the high pressure of compressed air as driving force at ambient temperature. The impulse and dynamic action of high pressure are responsible for the shaft work from air turbine.

4.1 Air Turbine and its Mathematical Model

A vaned type air turbine as shown in Figs. 1 and 2 has been considered. Air turbine is considered to work on the reverse of working principle of vane type compressor.

In this arrangement total shaft work is cumulative effect of isobaric admission of compressed air jet on vanes and the adiabatic expansion of

high pressure air. In an earlier study conducted by authors a prototype of air turbine was developed and its functionality was ensured. Vanes of novel air turbine were placed under spring loading to maintain their regular contact with the casing wall to minimize leakage. The present objective is to investigate the performance of an air turbine with the variation of rotor/casing dimensions. The air turbine considered has capability to yield output of 5.50 to 6.80 HP at 4-6 bar air pressure and for speed of 2000–2500 rpm, which is suitable for a motorbike. A cylinder for the storage of compressed air with a minimum capacity of storing air for the requirement of 30 min running at initial stage and maximum pressure of 20 bar is used as a source of compressed air.

The mathematical model shown here is already presented in author's earlier publication [46] which is now reproduced here for maintaining the continuity and benefits to the readers. The high pressure jet of air at ambient temperature drives the rotor in novel air turbine due to both isobaric admission and adiabatic expansion. The compressed air when enters through the inlet passage, pushes the vane for producing rotational movement and thereafter air so collected between two consecutive vanes of the rotor is gradually expanded up to exit passage, also contributes to the shaft out. This isobaric admission and adiabatic expansion of high pressure air both produces the total shaft power output from air turbine. Compressed air leaving the air turbine after expansion is sent out from the exit passage. Since scavenging of the rotor is perfect, thus the work involved in recompression of the residual air is absent.

From Figure 3, it is seen that work output is due to isobaric admission (E to 1), adiabatic expansion (1 to 4) and steady exit flow work (4 to 5). Thus, total work done due to thermodynamic process may be written as:

$$[\text{Area under (E145CE)}] = [\text{Area under (E1BOE)} + \text{Area under (14AB1)} - \text{Area under (4AOD4)} + \text{Steady Flow (45CD4)}]$$

$$\text{Total Work output} = [\text{Thermodynamic expansion work } (w_1)] + [\text{Exit steady flow work } (w_2)]$$

$$[(w_1)(w_2)] \quad (1)$$

From the above equation (1) thermodynamic expansion work can be written as:

$$w_1 = p_1 \cdot v_1 + \left(\frac{p_1 \cdot v_1 - p_4 \cdot v_4}{\gamma - 1} \right) - p_4 \cdot v_4 \quad \text{or}$$

$$w_1 = \left[\left(\frac{\gamma}{\gamma - 1} \right) \cdot (p_1 \cdot v_1 - p_4 \cdot v_4) \right] \quad (2)$$

From the above equation (1) steady flow work can be written as

$$w_2 = \int_4^5 v \cdot dp = (p \cdot v_4 - p_5 \cdot v_5) \quad (3)$$

After the expansion process during exit flow the pressure p_4 cannot fall below atmospheric pressure p_5 . Thus, from equation (1) the work output will be:

$$w = (w_1 + w_2) = \left(\frac{\gamma}{\gamma - 1} \right) \cdot p_1 \cdot v_1 \cdot \left\{ 1 - \left(\frac{p_4}{p_1} \right)^{\frac{\gamma - 1}{\gamma}} \right\} + (p_4 - p_5) \cdot v_4 \quad (4)$$

When air turbine is having n number of vanes, then shaft output [47] can be written as,

Applying values of v_1 and v_4 to equation (4), the total power output available W_{total} , can be written as:

$$W_{total} = n \cdot (N/60) \cdot \left(\frac{\gamma}{\gamma - 1} \right) \cdot \left\{ 1 - \left(\frac{p_4}{p_1} \right)^{\frac{\gamma - 1}{\gamma}} \right\} \cdot p_1 \cdot \left[L \cdot \left\{ \frac{(X_{1min} + X_{2min}) \cdot (2r + X_{1min})}{4} \right\} \cdot \sin \theta \right]$$

$$+ n \cdot (N/60) \cdot (p_4 - p_5) \cdot \left[L \cdot \left\{ \frac{(X_{1max} + X_{2max}) \cdot (2r + X_{1max})}{4} \right\} \cdot \sin \theta \right] \quad (5)$$

Where

$$X_{1min} = R \cdot \cos \left[\sin^{-1} \left\{ \left(\frac{R-r}{R} \right) \cdot \sin (180 - \theta - \phi) \right\} \right] + [(R-r) \cdot \cos (180 - \theta - \phi) - r]$$

$$X_{2min} = R \cdot \cos \left[\sin^{-1} \left\{ \left(\frac{R-r}{R} \right) \cdot \sin (180 - \phi) \right\} \right] + [(R-r) \cdot \cos (180 - \phi) - r]$$

$$X_{1max} = (D - d) = 2(R - r),$$

$$\text{and } X_{2max} = R \cdot \cos \left[\sin^{-1} \left\{ \left(\frac{R-r}{R} \right) \cdot \sin \theta \right\} \right] + \{(R-r) \cdot \cos \theta\} - r$$

4.2 Assumptions of Input Parameter

Detailed analysis of varying injection angles was carried out in earlier publications for expansion work, flow work, percentage contribution of expansion and flow work and total works at dif-

ferent injection pressure 2- 6 bar and different speed of rotation 500-2500 rpm. The contribution of total expansion work was found large when injection angle of air turbine is kept above 30° and found maximum when it is 60°, at constant: vane angle= 45° (i.e. 8 vanes), injection pressure= 6 bar and speed of rotation=2500 rpm.

In this study various input parameters are listed in Table 1 for investigation of for larger shaft output at different rotor to casing diameter ratios (d/D) with respect to different vane angles when casing diameter (D) is kept 50mm, 100 mm and 150mm, injection pressure= 6 bar (90 psi), injection angle=60° and speed of rotation=2500 rpm.

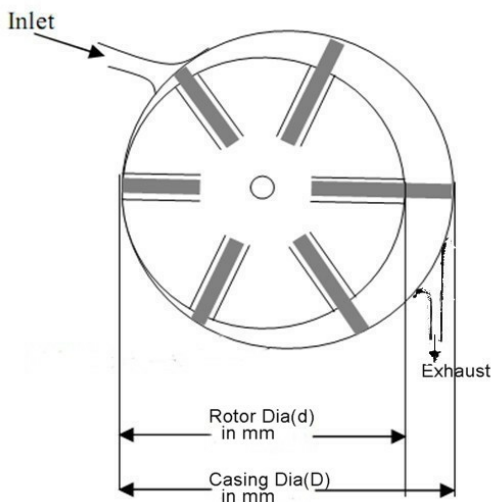

Fig.1 Air Turbine-Schematic Drawing

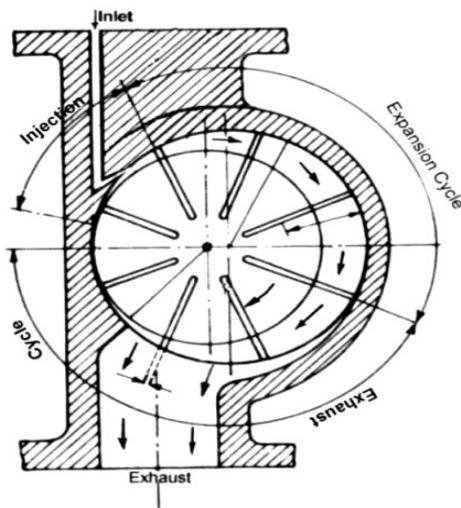

Fig.2 Air Turbine- Mode

4.3 Results and Discussion

Based on the various input parameters listed in Table 1 and using mathematical model, the effects of different rotor to casing diameters ratios with respect to different vane angles at speed of rotation 2500 rpm and injection pressure 6 bar, the total power outputs obtained from air turbine are studied and compared considering casing diameter as $D=50$ mm, 100 mm and 150 mm. Here the injection angle ϕ of the air turbine is considered to be constant at 60° as it was found to develop optimum shaft output in earlier studies. The results obtained have been plotted in Fig. 4, 5 and 6 for the rotor to casing diameter ratio (d/D)= 0.70 at different vane angles of 30°, 36°, 45°, 60°, 90° and at constant injection angle of 60° and injection pressures of 6 bar (90 psi) at the speed of rotation 2500 rpm. Fig. 7 shows the comparative results.

Case 1: Power output (W_t), when $D=50$ mm

Fig 4 shows that the total power from air turbine becomes large, for a particular vane angle and for different range of rotor/casing diameter ratio when injection pressure is 6 bar, speed of rotation is 2500 rpm, and it ranges from:

- 0.19 kW- 0.72 kW, when rotor to casing diameter ratios are of 0.95-0.80 and vane angle is kept 30° (vanes 12 nos.) and
- 0.87 kW- 1.0 kW, when rotor to casing diameter ratios are of 0.75-0.70 and vane angle is kept 36° (vanes nos. 10)

Case 2: Power output (W_t), when $D=100$ mm

Fig 5 shows that the total output power from

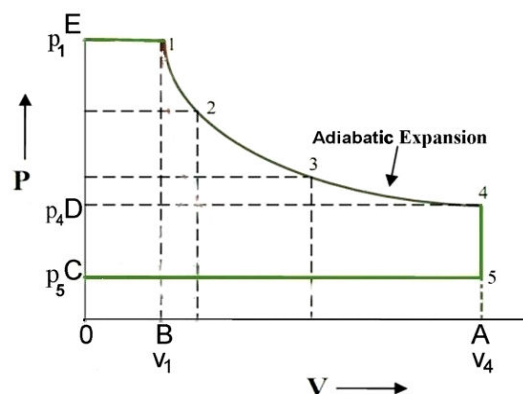

Fig. 3 Thermodynamic Processes (Isobaric, adiabatic and Isochoric Expansion)

the air turbine becomes maximum for a particular vane angle and for different range of rotor/casing diameter ratio when injection pressure is 6 bar, speed of rotation is 2500 rpm, and it ranges from 0.8 kW- 2.9 kW, when rotor to casing diameter ratios are of 0.95-0.80 and vane angle is kept 30° (vanes nos. 12).and 3.5 kW- 4.0 kW, when rotor to casing diameter ratios are of 0.75-0.70 and vane angle is kept 36° (vanes nos. 10)

Case 3: Power output (Wt), when D=150 mm

Fig 6 shows that the total output power from the air turbine becomes maximum for a particular vane angle and for different range of rotor/casing diameter ratio when injection pressure is 6 bar, speed of rotation is 2500 rpm, and it ranges from:

- 1.9 kW- 6.5 kW, when rotor to casing diameter ratios are of 0.95-0.80 and vane angle is kept 30° (vanes nos. 12). and
- 7.8 kW- 9.0 kW, when rotor to casing diameter ratios are of 0.75-0.70 and vane angle is kept 36° (vanes nos. 10)

Case 4: Comparison of Power output (Wt), when D=50 mm, 100mm and 150mm

Fig 7 shows that the total power output is seen maximum for a particular rotor / casing size and varies as: 1.0 kW, 4.0 kW and 9.0 kW at D= 50 mm, 100 mm and 150 mm respectively when (d/D) = 0.70, and vane angle (θ) is kept 30°-45° (vane numbers=12-8)

Table 1: Input Parameters

Symbols	Parameters
d/D ratio	0.70 when casing diameter is kept $D=50$ mm, 100 mm, and 150 mm
P_1	6 bar (=90 psi)
P_4	$(v_1 / v_4)^\gamma \cdot p_1 > p_5$ assuming adiabatic expansion
P_5	$(p_4 / 1.2) > 1.0132$ bar (atmospheric pressure)
θ	30°, 36°, 45°, 60°, 90° (i.e. rotor contains correspondingly 12, 10, 8, 6, 4 number of vanes)
N	2500 rpm (as total power is directly proportion to rpm)
L	45 mm length of rotor
γ	1.4 for air
n	Number of vanes = $(360 / \theta)$
ϕ	60° angle at which compressed air enters through nozzle into rotor

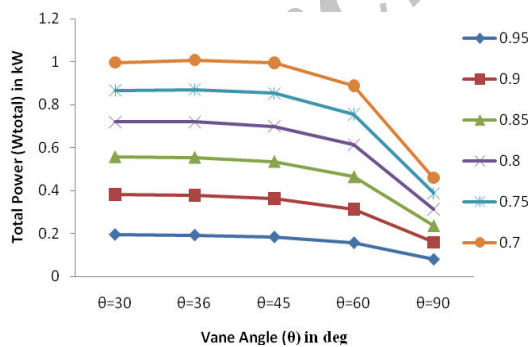

Fig.4: Total power output (Wt) versus different Rotor / Casing ratio at different vane angle when D=50 mm

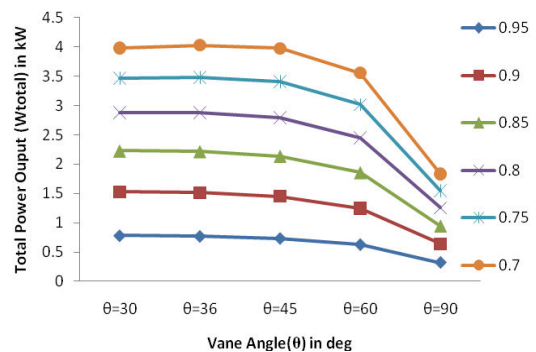

Fig.5: Total power output (Wt) versus different Rotor / Casing ratio at different vane angle when D=100 mm

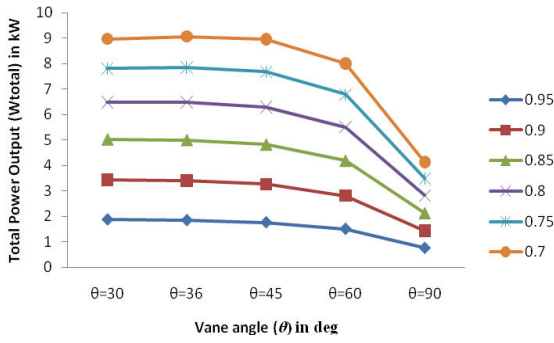

Fig.6: Total power output (Wt) versus different Rotor / Casing ratio at different vane angle when $D=150$ mm

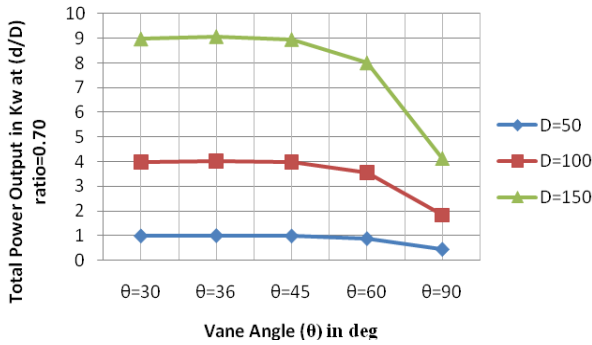

Fig.7: Total power output (Wt) versus vane angles when rotor / casing diameter (d/D) ratio is 0.70 when $D=50$ mm, 100 mm, and 150 mm

5. Conclusions

In view of fast depleting fossil fuel reserves and growing energy requirements, compressed air storage system has immense potential to be utilized as an alternative to fossil fuel. From the present study, the following conclusions are drawn:

- The atmospheric air having enormous reserves as working fluid could reduce the tail pipe emission and resolve the environmental and ecological problems to a large extent.
- Compressed air driven engines will offer an attractive alternative to meet the forthcoming fossil fuel crisis.
- The total output power from the novel air turbine under theoretical considerations is seen to be maximum for the higher injection air pressure and there exists an optimum value of rotor/casing diameter ratio for injection

pressure 6 bar, speed of rotation 2500 rpm and at particular vane angles and it ranges from: 1.0 kW, 4.0 kW and 9.0 kW at $(d/D) = 0.70$ at $D= 50$ mm, 100 mm and 150 mm respectively when vane angle (θ) is kept 36° (vane number 10).

Thus optimum shaft power output of a novel vanned type air turbine is obtained when the design parameters for rotor diameter to casing diameter (d/D) ratios is kept between 0.70 to 0.75 and vane angle is $30-45^\circ$ (i.e. rotor vane numbers 12 - 8), which develops desired shaft output for a particular size of vane turbine. Such air turbine is suitable for running light vehicle / motorbike and found cost effective, develops 75-97% performance efficiency of converted / stored energy and releases zero emission as compared to fossil fuel energy resources.

Nomenclature

d	diameter of rotor ($2r$) in meter
D	diameter of outer ($2R$) cylinder in meter
L	length of rotor having vanes in meter
n	no. of vanes= $(360/\theta)$
N	no. of revolution per minute
p_1, v_1	pressure (in bar) and volume (in m^3) respectively at which air strike the Turbine,
p_4, v_4	pressure (in bar) and volume (in m^3) respectively at maximum expansion of air
p_5	pressure (in bar) at which turbine releases the air to atmosphere.
v	volume in in m^3
w	theoretical work output in Nm
W	theoretical power output (Nm/s)
X_{li}	variable extended lengths of vane at point 1 in metre

X_{2i} variable extended lengths of vane at point 2 in metre

Subscripts

$1, 2, \dots, 4, 5$ subscripts – Indicates the positions of vanes in casing.

e, exp expansion

f, flow flow

min minimum

max maximum

t, total total

Greek symbols

α angle BOF

α_1 angle LOF (=180- ϕ)

α_2 angle KOF (=180- θ - ϕ)

β angle BAF

γ 1.4 for air

θ angle between 2-vanes(BOH)

ϕ angle at which compressed air enters into rotor through nozzle

Acknowledgments

The Authors would like to express thanks to the Management of School of Management Sciences, Technical Campus, Lucknow and Harcourt Butler Technological Institute, Kanpur for their support to avail facilities of Library and Laboratories.

References

- [1] Hubbert M.K., Nuclear energy and the fossil fuels; Amer. Petrol. Inst. Drilling and Production Practice, Proc. Spring Meeting, San Antonio, Texas. 1956, pp 7-25, web: www.hubbertpeak.com/de/lecture.html.
- [2] Aleklett K. and Campbell C.J., The Peak and Decline of World Oil and Gas Production- Minerals and Energy, Raw Materials Report, Volume 18, Number 1, 2003, pp. 5-20(16).
- [3] Badr O., O'Callaghan P. W., Hussein M., and Probert S. D., Multi-vane expanders as prime movers for low-grade energy organic Rankine-cycle engines, Applied Energy, 16 (2), 1984, pp. 129-46.
- [4] D., Multi-vane expander performance: breathing characteristics, Applied Energy, 19(4), 1985, pp. 241-71.
- [5] Badr O., Probert S. D., and O'Callaghan P. W., Multi-Vane Expanders: Vane Dynamics and Friction Losses, Applied Energy 20, 1985, pp. 253-285.
- [6] Badr O., O'Callaghan P. W., and Probert S. D., Multi-vane expanders: geometry and vane kinematics, Applied Energy, 19(3), 1985, pp. 159-82.
- [7] Badr O., Probert S. D., and O'Callaghan P. W., Multi-Vane Expanders: Internal-Leakage Losses, Applied Energy, 20, 1985, pp.1-46.
- [8] Badr O., Probert S. D., and O'Callaghan P.W., Performances of Multi-vane Expanders, Applied Energy, 20, 1985, pp.207- 234.
- [9] Badr O., Probert S. D., and O'Callaghan P. W., Influences of Vane Design and Lubricant on a Multi-Vane Expander's Performance, Applied Energy, 22, 1986, pp. 271-298.
- [10] Badr O., Probert S. D., and O'Callaghan P. W., Optimal Design and Operating Conditions for a Multi-vane Expander, Applied Energy, 24, 1986, pp. 1-27.
- [11] Badr O., Probert S. D. and O'Callaghan P. W., Selection of Operating Conditions and Optimisation of Design Parameters for Multi-Vane Expanders, Applied Energy, 23, 1986, pp. 1-46.
- [12] Yang B., Peng X., He Z., Guo B., and Xing Z., Experimental investigation on the internal working process of a CO2 rotary vane expander, Applied Thermal Engineering, 29, 2009, pp. 2289–2296.

- [13] David Huang K., and Sheng-Chung Tzeng, Development of a hybrid pneumatic-power vehicle, *Applied Energy*, 80, 2005, pp. 47–59.
- [14] David Huang K., Sheng-Chung Tzeng, Wei-Ping Ma, and Wei-Chuan Chang, Hybrid pneumatic-power system which recycles exhaust gas of an internal-combustion engine, *Applied Energy*, 82, 2005, pp. 117–132.
- [15] David Huang K., Khong Vu Quang, and Kuo-Tung Tseng, Study of recycling exhaust gas energy of hybrid pneumatic power system with CFD, *Energy Conversion and Management*, 50, 2009, pp. 1271–1278.
- [16] David Huang K., Khong Vu Quang, and Kuo-Tung Tseng, Study of the effect of contraction of cross-sectional area on flow energy merger in hybrid pneumatic power system, *Applied Energy*, 86, 2009, pp. 2171–2182.
- [17] H.J. van Antwerpen, G.P. Greyvenstein, Use of turbines for simultaneous pressure regulation and recovery in secondary cooling water systems in deep mines, *Energy Conversion and Management*, 46, 2005, pp.563–575.
- [18] Donghong Wei, Xuesheng Lu, Zhen Lu, Jianming Gu, Performance analysis and optimization of organic Rankine cycle
- [19] (ORC) for waste heat recovery, *Energy Conversion and Management*, 48, 2007, pp.1113–1119.
- [20] Jean-Michel Tournier, Mohamed S. El-Genk, Axial flow- multi-stage turbine and compressor models, *Energy Conversion and Management*, 51, 2010, pp.16–29.
- [21] B. Yang., X. Peng, Z. He, B. Guo, Z. Xing, Experimental investigation on the internal working process of a CO₂ rotary vane expander, *Applied Thermal Engineering*, 29, 2009, pp. 2289–2296.
- [22] J. Nickl, G. Will, H. Quack, W.E. Kraus, Integration of a three-stage expander into a CO₂ refrigeration system, *International Journal of Refrigeration*, 28, 2005, pp.1219–1224.
- [23] A. Subiantoro, K.T. Ooi, Analytical study of the endface friction of the revolving vane mechanism, *International journal of refrigeration*, 34, 2011, pp.1276-1285.
- [24] Shen Yu-Ta, and Hwang Yean-Ren, Design and implementation of an air-powered motorcycle, *Applied Energy*, 86, 2009, pp. 1105–1110..
- [25] THE PLANNING GROUP, Sustainable and Land Development Study, ENV. Australia, 2002.
- [26] Govt. of WA, Focus on the Future Sustainable and Land Development Study-The Western Australian State Sustainability Strategy- Consultation Draft, 2002, pp.8.
- [27] Jafarmadar, S.; Zehni, A., Modeling the Effect of EGR on Com-bustion and Pollution of Dual Fuel Engines With Flow Field Model, *International Journal of Energy and Environmental Engineering (IJEEE)*, 173, Sepahbod Gharani Ave., Tehran, Iran, ISSN: 2008-9163, Vol.1(1), 2010, pp. 19-26.
- [28] R. G. Papagiannakis, Comparative Evaluation of the Effect of Partial Substitution of Diesel Fuel by Natural Gas on Performance and Emissions of a Fumigated Dual Fuel Diesel Engine, *International Journal of Energy and Environmental Engineering(IJEEE)*, 173, Sepahbod Gharani Ave., Tehran, Iran, ISSN: 2008-9163, Vol.2(2), 2011, p.31-43.
- [29] O. Jahanian, S. A. Jazayeri, A Numerical Investigation on the Effects of Using for Maldehyde as an Additive on the Performance of an HCCI Engine Fueled With Natural Gas, *International Journal of Energy and Environmental Engineering(IJEEE)*, 173, Sepahbod Gharani Ave., Tehran, Iran, ISSN: 2008-9163, Vol.2 (3), 2011, pp.79-89.
- [30] Atcitty, S., Ranade, S., Gray-Fenner, Amber, Summary of State-of-the-Art Power

- Conversion Systems for Energy Storage Applications- Sandia National Laboratories - Report SAND98 – 2019, 1998.
- [31] Negre Guy and Negre Cyril, Compressed Air - The Most Sustainable Energy Carrier for Community Vehicles, Speech in front of assembly at Kultur gathered for Fuel Cells World, Tuesday 29th June '2004.
- [32] Saint Hilaire G., Saint Hilaire R. and Saint Hilaire, Y., Quasiturbine zero pollution car using gasoline. Festival at Le Lundi, Montreal Gazette, 26 September 2005.
- [33] Fuglsang P., Bak C. and Gunna M., Design and verification of the Ris0-B1 Airfoil-family for Wind Turbines, Journal of Solar Energy Engg., ASME- Nov'2004, Vol.126 pp 1002-1008.
- [34] Gorla R. and Reddy, S., Probabilistic Heat Transfer and Structural Analysis of Turbine Blade, IJTJE, Vol. 22, 2005, pp 1-11.
- [35] Selig Michel S. and Bryan D. McGranahan, Wind Tunnel Aerodynamics Tests of Six Airfoils for use on Small Wind Turbines, Journal of Solar Energy Engg., ASME-Nov' 2004, Vol.126, pp 986-1000,.
- [36] Schreck S. and Robinson M, Tip Speed Ratio Influences on Rationally Augmented Boundary Layer Topology and Aerodynamic Force Generation, Journal of Solar Energy Engg., ASME-Nov' 2004-Vol.12pp1025-1033, DOI:10.1115/1.1793209.
- [37] Singh B.R. and Singh Onkar, Development of Novel Air Turbine, International Conference at Honolulu, Hawaii-on 17th-22nd Feb, 2008; Paper No. ISROMAC 12-2008-20046.
- [38] Singh B.R. and Singh Onkar, A Study on Sustainable Energy Sources and its Conversion Systems towards Development of an Efficient Zero Pollution Novel Turbine to be used as Prime-mover to the Light Vehicle, 2008 ASME International Mechanical Engineering Congress and Exposition, held on October 31-November 6, 2008 at Boston, Massachusetts, USA- Paper No. IMECE -2008 -66803, Vol.8, 2008, pp371-378, DOI:10.1115/IMECE2008-66803.
- [39] Singh B.R. and Singh Onkar, Development of a vaned type novel Air Turbine, International Journal of Mechanical Engineering Science, Proc. IMechE Part: C JMES993, Vol. 222(12), 2008, pp 2419-2426, DOI:10.1243/09544062JMES993.
- [40] Singh B.R., and Singh Onkar, Analytical Study on a Vaned Type Novel Air Turbine for Different Conditions of Casing and Rotor Diameters, 2009 ASME International Conference on Energy Sustainability, held on July 17-23, at San Francisco, California, USA, Paper No. ES2009 -90207, Volume 1, 2009, pp. 699-706, DOI: 10.1115/ES2009-90207.
- [41] Singh B.R., and Singh Onkar, Effect of Different Vane Angle on Rotor - Casing Diameter Ratios to Optimize the Shaft Output of a Vaned Type Novel Air Turbine, International Journal of Engineering Science and Technology, Chennai, India, IJEST-ISSN-0975-5472, Vol. 2, Number 3 (2), 2010, pp 114-121.
- [42] Singh B.R. and Singh Onkar, Study of Effect of Injection Angle to Rotor-Casing Diameter Ratios on Performance of a Vaned Type Novel Air Turbine, International Journal of Engineering Science and Technology, Chennai, India, IJEST-ISSN-0975-5472, Vol. 2, Number 4 (10), 2010, pp 409-417.
- [43] Singh B.R. and Singh Onkar, Critical Effect of Rotor Vanes with Different Injection Angles on Performance of a Vaned Type Novel Air Turbine- International Journal of Engineering and Technology, Chennai, India, IJET-ISSN: 0975-4024, Vol. 2 Number 2(28), 2010, pp. 118-123
- [44] Singh B.R. and Singh Onkar, Study of Influence of Vane Angle on Shaft Output of a Multi Vane Air Turbine"- International Journal of Renewable and Sustainable Energy, AIP, New York, USA, ISSN:

1941-7012, Vol.2 Number 3, 2010, pp. 033101-16. DOI:10.1063/1.3424712.

- [45] Singh B.R. and Singh Onkar, Analytical Investigations on Different Air Injection Angles to Optimize Power Output of a Vaned Type Air Turbine, International Journal of Power and Energy, Westminster, London- SW1H 9JJ, UK, Proc. of IMechE, Part A: JPE-837, ISSN 0957-6509; Vol. 224, Number 3, 2010, pp. 305-312, DOI:10.1243/09576509JPE837.
- [46] Singh B.R. and Singh Onkar, Study of Effect of Rotor Vanes to Rotor-Casing Dimensions on Performance of a Zero Pollution Vane Type Novel Air Turbine, International Journal of the Physical Sciences, 5170-00200, Nairobi-73023 Victoria Island, Lagos, ISSN 1992-1950, Vol.5(5), 2010, pp. 547-556.
- [47] Singh Onkar, 2009, Reciprocating and Rotary Compressor, Applied Thermodynamics, New Age International (P) Ltd., Publishers, New Delhi, India, ISBN: 978-81-224-2583-3, Feb 2009, pp797-798.

Biographies



Prof. (Dr.) Bharat Raj Singh—was born in Sultanpur Distt., Uttar-Pradesh, India on 30th June' 1947. He received B.E.(Mechanical) degree from SVNIT, Surat, South Gujarat University in 1972, M.E.(Analysis & Design of Process Equipments) from MNNIT, Allahabad University in 1988 and Ph.D. from GB Technical University, Lucknow, India in 2011. Currently he is serving as Associate Director and Professor & Head of Department –Mechanical Engineering, School of Management Sciences, Technical Campus, Lucknow, India. He also served about 8 years at various positions in the Academic field such as: Professor Head of Department-Mechanical Engineering, Dean-Academics, Administrations and Deputy Director at Sagar Institute of Technology and Management, Barabanki, India and

many Industries and Government organizations about 32 years. He was recipient of many recognitions and awards. He attended National and International Symposium, Conferences. He published about 51 papers at his credits in the leading Journals of International, National reputes and Proceedings. He also authored 2-books (Design and Development of Novel Air Engine and The Impact of Air Pollution). Has a specialization in the field of Unconventional Manufacturing Processes, Industrial Engineering, Thermodynamics and Automobiles. His research field is in Sustainable Energy Resources, Environment and Development of zero pollution air engines. He is member of Editorial Boards and Reviewers of many leading Journals. The author became a Member (MIE) of The Institution of Engineers (India) in 1978, CE (I) in 1985, and a Fellow (FIE) in 1985. He is also member of International Association of Engineers (IAENG-105641) in 2010.



Prof. (Dr.) Onkar Singh—was born in Unnao Distt., Uttar-Pradesh, India on 8th Oct.'1968. He received B.Tech. (Mechanical) degree from HBTI, Kanpur in 1989, M.Tech and Ph. D. from MNNIT, Mechanical Engineering Department, Allahabad University in 1991 and 1999-2000 respectively. Currently he is serving as Professor, Head of Department of Mechanical Engineering. He is recipient of AICTE Young Teacher Career Award in year 2000. He has at his credit approximately 100 numbers of papers published in International and National Journals and authored 5- books on Engineering Thermodynamics, Applied Thermodynamics, and Introduction to Mechanical Engineering, Challenges and Strategies of Sustainable Energy. His specialization area is Thermodynamics, Mechanical Process Machines, Industrial Engineering and Automobiles. His research field is in cooling devices for Turbine vanes, Biodiesels, Hybrid Engines, Sustainable energy resource, and Development of zero pollution air engines. He guided 6-Ph.D. students and 6-M.Tech., and 11-B.Tech., student's dissertations. He is member of Editorial Boards and Reviewers of many leading Journals. The author became a Member (M) of The Institution of Engineers (India) in 1999, Life Member, Indian Society for Technical Education and Life Member, Oil Technologists Association of India.