

ACTIVE CONTROL OF WIND-INDUCED BUILDING VIBRATION USING A LINEAR COUPLING STRATEGY

*S. M. Hashemi¹, M. F. Golnaraghi²

1. Department of Aerospace Engineering,
Ryerson University, Toronto (ON), Canada M5B 2K3

2. Department of Mechanical Engineering,
University of Waterloo, Waterloo (ON), Canada N2L3G1

ABSTRACT

The active control of building vibration is addressed. The aeroelastic lumped mass model of a building is designed to be used as the test bed for the active control system. The five story lumped parameter model was modeled as a cantilever beam exhibiting planar vibration. A Linear Coupling Control (LCC) strategy was implemented to eliminate the vibrations. An active (moving) mass damper (AMD) was first designed and experimentally implemented to control the first mode vibration of the system. An alternative pendulum control system was then designed and implemented. The proposed pendulum, having three times smaller mass than the AMD, was found to be more effective in reducing the building vibrations.

Keywords: vibrations, active vibration control, aeroelastic model, linear coupling

1. INTRODUCTION

Continued urbanization and localization of people into massive city centers fuel the desire to reach for the sky. Taller buildings are required to satisfy space requirements in such a clustered environment. Wind loading can produce severe structural vibrations in such flexible structures. As buildings increase in height, flexibility will become critical in defining their structural integrity. The structural flexibility compromises human comfort levels in the building to a far greater degree than structural integrity. According to studies summarized by Simiu and Scalman [1], average human perception thresholds to translational vibration ranges from 0.6% of g at 0.1Hz to 0.3% of g at 0.25Hz. Test subjects found vibration levels above 1.2% of g annoying and had difficulty walking under vibration levels exceeding 4% of g . Also with increasing concerns for human comfort in the workplace, recent acceleration criteria have become such stricter so that building designers are finding it difficult to meet the regulations for tall structures.

There have been numerous investigations, both analytical/numerical and experimental, into the area of passive vibration control of tall buildings [2-21]. The basic concept for these devices is to increase the effective damping of the structure near a critical mode of vibration by

* E-mail address of the corresponding author: Smhashemi@ryerson.ca

dynamically coupling the structure to an absorber system.

The water in a vessel absorbs energy of vibration of a main structure as kinetic energy of sloshing motion, and dissipates it through the shear of the water, friction between water and wall, collision of floating particles and so on. The energy is converted into heat finally. Based on the principle of the dissipation of energy through sloshing liquid, another type of passive vibration absorbers, called Tuned Liquid Dampers (TLD) [6,8-11,13-17,20] have been developed. TLDs have performed successfully in passively mitigating undesirable structural motion under a variety of settings. Reporting full-scale measurements of the wind-induced responses of four buildings, Tamura *et al.* [2] proved the efficiency of TLDs and demonstrated that the TLDs could significantly improve the serviceability of the buildings. Modi *et al.* [3] briefly reviewed the developments in the area of vibration suppression through application of nutation dampers used as a useful concept in minimizing the effects of fluid-induced instabilities. The Reference [3] also provides a comprehensive literature survey of nutation dampers and its application to the ocean-based riser problems, reducing the response to seismic excitations, and numerous other engineering situations of practical importance where this type of dampers or their variations can be adapted to control vibrations. A study was carried out by Fediw *et al* [6] to investigate and evaluate the performance of a one-dimensional Tuned Sloshing Water Damper (TSWD).

An effective method was developed, and was experimentally verified, to increase the inherent damping and therefore the performance of the TSWD. Tamura *et al.* [8] studied the wind-induced responses of the Tokyo International Airport Tower to investigate the efficiency of the Tuned Liquid Dampers (TLD) [5]. A number of shallow circular vessels containing water and floating particles were used to evaluate the damping ratio and the natural frequency of the tower with and without TLD. The damping ratio of the main structure was increased by the TLD up to 8% during the strong winds, and the efficiency of this absorber system was confirmed to be satisfactory. Modi and Seto [9] addressed the control of flow induced oscillations, such as resonance and galloping type of wind-induced instabilities, using passive rectangular nutation dampers. A numerical approach, accounting for nonlinear effects including the effects of wave dispersion as well as boundary-layers at the walls, floating particle interactions at the free surface and wave-breaking, was proposed which is able to capture the system dynamics rather well. Investigating rectangular TLD through shaking table tests and numerical modeling for large amplitude excitation, Reed *et al.*[11] addressed the underlying physical phenomenon of the liquid sloshing motion that mitigates the structural vibration to present a better understanding of the problem and to provide insight into the behaviour of TLDs in controlling structural vibration. The Liquid Column Vibration absorber (LCVA) [13,14], which allows the column cross-section to be non-uniform, is a variation of the Tuned Liquid Column Dampers (TLCD) [10, 15, 16]. These vibration absorbers as passive control devices can suppress the structural vibration by the motion of liquid in a column container. They (both U-shaped and V-shaped) provide some advantages such as low cost, easy installation and adjustment of liquid frequency.

The application of TLCD for the suppression of structural pitching vibration was also investigated by Xue *et al.* [20]. Since the structural frequency and damper frequency are subject to change and a certain level of error in tuning frequency ratio and damping ratio is unavoidable, the use of Multiple Tuned Liquid Column Dampers (MTLCD) has been suggested which can enhance the efficiency of the system [14,17].

Vibration absorber systems such as Tuned Mass Dampers (TMD) have been widely used in mechanical systems. In recent years, TMD theory has been adopted to reduce vibrations of tall

buildings and also other civil engineering structures [4, 7, 17, 18, 19, 21]. Basically, a TMD is a device consisting of a mass attached to a building or structure such that it oscillates at the same frequency as the structure but with a phase shift. The mass is usually attached to the building via a spring-dashpot system and energy is dissipated as relative motion develops between the mass and the structure. TMDs have proven to be effective for certain applications but they are not perfect and are limited in the magnitude of motion reduction they can achieve. In addition, TMD must be tuned to the mode of the structure that is to be damped. A comprehensive literature survey on TMD systems has been presented in Reference [4].

Considering a one-DOF system fitted with a TMD, the paper presented the parametric studies and the theoretical assessment of the performance of TMD systems. It was also shown that the effectiveness of a TMD on the response of a single DOF system could be readily extended to continuous structures such as tall buildings by a modal approach [4]. Verification of the effectiveness of TMDs on the large torsional motions of a bridge, using wind tunnel section model tests, and with the aim of optimizing the TMD design was presented in [12]. The directional passive mass dampers for vibration attenuation of multi-winged buildings under wind or seismic loads were introduced by Ankireddi and Yang [7]. Varying many parameters of the TMD design, it was shown that the greatest improvement in bridge deck performance could be achieved by increasing the TMD mass moment of inertia ratio, either by increasing the distance from the TMDs to the bridge centreline or by increasing the moving mass of the TMD. The control performance of TMD, TLCD, and LCVA vibration absorbers on suppressing excessive building vibration was compared in [18]. It was shown that the performance of these mass dampers depends on a parameter termed as efficiency index of the system. As a single TMD cannot provide vibration control for more than one mode [19] therefore, investigations have been made regarding controlling multiple structural modes using Multi-Tuned Mass Dampers (MTMD). The multiple passive-damping systems would be another alternative to control more than one mode of vibration in a building. Illustrating the practical considerations and vibration control effectiveness of passive TMDs for irregular buildings, Lin *et al.* [21] used two mass dampers to achieve the largest seismic response reduction of buildings modelled as multi-storey torsionally coupled shear structures. Alternative passive, semi-active and active dampers have also been investigated [3, 22, 23, 24-36]. The limitations of the passive and semi-active vibration control devices have led to the development of active devices.

Research into active structural control has been ongoing since the early 70s, and different theories for active control have been extensively investigated and it has been found to be a superior method of vibration control. Active control has the advantage of being able to adapt to changes in building parameters. It is also possible to use active control over multiple modes of vibration with one actuator. Active controllers are typically lighter than passive controllers and the selection of an active alternative is the result of economical and performance considerations within the specified constraints. Although active control systems require extra support hardware, these devices can be removed from the top floor of the building and relocated to more appropriate floors. These devices use a control algorithm, which analyses the dynamic structural feedback to create a control force, which drives a mass. The active controller has attracted many researchers in the recent years [27-36]. A comprehensive literature survey of this subject can be found in Reference [34].

The development of a one-DOF Active Tuned Mass Damper (ATMD) installed in the top of a rectangular model building for vibration testing in a wind tunnel, together with the related control theory were presented by Facioni *et al.* [27]. It was demonstrated that the active vibration

control performance of the system could be improved by simply modifying some ATMD's parameters. A method for selecting design parameters of AMDs and estimating motion reduction of wind-excited tall buildings based on aeroelastic model tests of uncontrolled tall buildings was proposed by Xu [28]. Using acceleration sensors, it was shown that wind-induced response of the building could be substantially reduced if the parameters of the AMD are selected appropriately. Based on the theory of variable structure system (VSS) or sliding mode control (SMC), Yang *et al.* [29] proposed control methods for applications of active VSSs, interpreted based on the concept of the dissipation of hysteretic energies, to seismic-excited buildings. The active control of the first mode of vibration of slender wind-loaded buildings was studied by Mackriell *et al.* [30]. An algorithm using acceleration feedback from the top of the building was used, as was a range of empirical algorithms using some combination of feedback from the first mode of vibration of the building. The algorithm using pure acceleration feedback produced the best performance for the building. An experimental research program was also performed by Chang *et al.* [31] to investigate the Active Tuned Liquid Damper (ATLD), incorporating a simple control strategy. Cao *et al.* [32] emphasized the use of a single mode approach vs. the multi-modal approach, for the design evaluations of AMDs incorporating the nonlinear control strategies. It was demonstrated that neglecting any of issues related to the performance, the physical constraints and frictional effects, might result in an inadequate solution. The active control and reliability of a structure under wind excitation was addressed by Battaini *et al.* [33], where performance of fuzzy control schemes under random excitation and parameter uncertainties was investigated.

The present paper describes the development of a 1:250 scale aeroelastic model building and an Active Mass Damper (AMD) based on a Linear Coupling Control (LCC) strategy. An alternative Active Pendulum Damper (APD) system is also designed and implemented. The proposed APD, having one-third of mass of the AMD, was found to be more effective in reducing the building vibrations.

2. AEROELASTIC MODEL

The initial steps, was to design an aeroelastic lumped mass model of a building to be used as the test bed for the active control system. The main purpose of this model is to mimic the dynamic response of the original building on an appropriate scale for vibration tests and ultimately in wind tunnel. Hence, care was taken that the proper scaling procedure be implemented and that emphasis be placed on capturing relevant building dynamics in scaled model. The aeroelastic lumped mass model is easier to build than continuous models, and do not require the use of exotic materials. It was also decided that a minimum of five masses be used in the model.

The criteria for the aeroelastic model were chosen so as to minimize the error between the structural response of the model and that of the actual building. Non-dimensional data for bending mode shapes in-plane ($x-x$) and out-of-plane ($y-y$) deflections and torsional deflections for the first three modes of the building, and also the mass distribution within the building were known. Extra data with regard to the mode shapes of the structure were also available but only mode shapes that were relevant to the problem at hand were modeled aeroelastically. As the cross section of the building is non-circular and varies with height, considering the torsional modes of the structure will be theoretically daunting. The building in question is tall and slender which means that torsional moments imparted by winds will be less significant than normal

forces exerted by the wind. Therefore, if coupling between the torsional and translational modes is small, the torsional modes of the structure can be neglected. From the provided data [37], at modes 1 and 2 the torsional response of the building is 0.04% and 4.8% of the dominant translational response of the structure. This is negligible and therefore the torsion will be neglected in the analysis.

Study was also done to quantify coupling between the two translational modes of the structure. From observation of the response in x-x and y-y at modes 1 and 2, the non-dominant deflections are 16.7% and 19.6% of the dominant deflections. This shows relatively insignificant coupling between modes. Therefore it was assumed that the translational modes of the structure are uncoupled and matching each mode could be done separately.

The modal frequencies, total mass, and approximate modal damping of the actual building were also available and were scaled using scaling laws. The criteria for the aeroelastic model are to minimize error of the following characteristics between the actual building and the model:

- Mass distribution,
- Uncoupled mode shapes,
- Natural frequency
- Modal damping.

The constraints placed on the aeroelastic model are that the model must be

- Lumped-parameters model including five masses,
- Less than 2 m tall.

2.1 Scaling Procedure

Similarity of the aeroelastic mathematical model to the actual building was maintained during the scaling procedure. As the building in question is equipped with a pendulum passive-damper system, therefore the gravitational effects are critical in the use of such a damping system as gravitational forces define the natural frequency of this damper. In order to maintain an accurate representation of the gravitational influence on the passive damper, Froude number

$$F_r = \frac{U^2}{D \cdot g} \quad (1)$$

similarity was maintained [1,37], where U is a reference flow velocity, D is a reference length scale and g is the acceleration due to gravity. For Froude number similarity to be maintained, the Froude number of the aeroelastic model and actual building must be equal.

To accurately portray wind-structure interactions in the aeroelastic model, similarity of the Strouhal number [37]:

$$S = \frac{D \cdot n_s}{U} \quad (2)$$

leading to reference mechanical frequency, n_s , associated with the structure, was also maintained. This is the most critical number that must be kept equal for the aeroelastic model and the actual building, as it is necessary for dynamic similarity.

Ratios among any characteristic of the fluid or structure must be maintained during scaling. This implied that the model had to be geometrically scaled. Therefore the aeroelastic model out to have the same aspect ratios for linear dimensions as the actual building.

The ratio between the density of the air and the building should also be maintained. This relationship is shown in the following

$$\left(\frac{\rho_s}{\rho_f} \right)_m = \left(\frac{\rho_s}{\rho_f} \right)_p \quad (3)$$

where ρ_s and ρ_f are the density of the structure and the fluid respectively. Subscripts m and p denote the model and the actual structure properties, respectively. Since the density of air in both the wind tunnel and the actual building environment are equal, the density of the model and building must also be equal.

Reynolds number similarity was relaxed due to the nature of the building profile [1]. Other dimensionless numbers that were relaxed during the scaling procedure are Prandtl, Eckert and Richardson numbers. The structure had to be scaled with respect to some building or flow property. The height of the building was used for this purpose, and was the basis of the scaling procedure. The top floor actual building is approximately 447m high. A scaling factor of 1:250 is chosen to bring this height below 2m. The height relationship becomes

$$\left(\frac{\rho_p}{\rho_m} \right) = 250 \quad (3)$$

Fixing this scaling factor automatically fixes other scaling relationships. From Froude Number similarity

$$\left(\frac{U_p}{U_m} \right) = \sqrt{\frac{D_p}{D_m}} \quad (4)$$

Inserting this information into the Strouhal number gives

$$\left(\frac{n_p}{n_m} \right) = \sqrt{\frac{D_m}{D_p}} \quad (5)$$

Lastly, maintaining density similarity, forces the following relationship

$$\left(\frac{m_p}{m_m} \right) = \left(\frac{D_p}{D_m} \right)^3 \quad (6)$$

After enforcing the scaling laws mentioned above, the data appearing in Table 1 was produced.

Table1 Actual and aeroelastic model data

	Height [m]	Mass [kg]	Frequency [Hz]
Actual Building	447	249,000,000	0.1573
Aeroelastic Model	1.792	15.986	2.487

2.2 Synthesis

Once the general properties of the structure (i.e., the parameters in questions) were scaled, it was necessary to create a model that not only matches these properties, but also matches the available mode shape, and mass distribution data.

Tall buildings behave similar to beams. Therefore initial attempts at correlating a model to provided data involved generating a coupled set of non-dimensional partial differential equations for building deflections in x and y as a function of time. Non-dimensionalization of the equations was performed such that a function for the mass distribution of the building could be implemented directly into the model. The second moment of area is modified to force the mode shape of the distributed parameter problem to match the actual available mode shape. Although a solution to this problem is possible, it would require discretizing the distributed parameter system and solving for the mode shape using a finite element method.

Also, after obtaining an accurate representation of the building dynamics, a lumped-parameter model would still have to be created. Therefore, the focus of this part of the project was directed to a lumped-parameter model developed using a finite element package such as IDEASTM. Beam elements could be used to connect lumped masses in the approximated building. The second moment of area for each beam cross-section could be modified in an iterative procedure until available data is matched. Although this is a valid approach it would be extremely time consuming. In addition, request for design changes or modifications, would necessitate the entire iterative procedure to be repeated. After initial studies into the complexity of the problem to be solved, this approach was also abandoned.

To overcome the problems mentioned above, a procedure was developed based on the influence flexibility approach described by Inman [38]. The purpose of this approach was to solve a simultaneous set of equations for the required properties of the beams in the lumped-parameter system to match the available information. The approach is well defined by Toth [37] and is briefly explained here. First the mass matrix is generated. The lumped parameter model consists of n representative masses connected by n constant cross-section beams. Each mass is selected to represent a group of floors in the building. The combined weight of these floors is lumped into the mass. The height at which each mass is located is calculated from the first moment the floors that it represents. At this stage, the mass locations could be altered such that the masses are lumped at critical locations. The stiffness matrix is then generated using the influence flexibility method [38] where it is defined as the inverted symbolically evaluated

TMSDRC I-DEAS is a trademark of Structural Dynamics Research Corporation

flexibility matrix. Assuming small deflections, the beams were assumed to satisfy all Euler-Beroulli assumptions. It was also assumed that external loading might only be applied to lumped-masses. This assumption is valid given that all external geometry added to the model structure, completing shape of the aeroelastic model, will be built off of the lumped masses. Once both the mass and stiffness are defined, the equations of motion for lumped-parameter system can be written. Assuming the general solution is oscillatory in nature, and based on known first mode shape and frequency, the system eigenvalue problem is written. This formulation defines n non-linear equations in n unknowns (I_i). These can be solved for all I_i by an iterative method.

The above-mentioned technique for creating the lumped-parameter aeroelastic model of the building is validated using a finite element model of the structure. Finite element results indicate the first natural frequency of the lumped model to be $\approx 2.463\text{Hz}$. The desired principal frequency for the aeroelastic model is 2.487Hz . This gives an error of 0.965% which deemed negligible. The mode shape for the finite element model is found to match the actual building mode shape exactly. The details on this procedure (initial guess, approximating the damping matrix, procedure validation, etc.) are well explained in [37]. The lumped mass-beam model structure is shown in Figure 1.



Figure 1 Final structure of scaled model

3. ACTIVE CONTROL

The primary objective for this phase of the project was to accomplish active control of the scaled building's first mode of vibration in one direction, simulating the wind induced excitation. It was assumed that if this goal could be achieved, application of similar components and theory would allow control of both higher order modes as well as vibration in both planes of building motion. In order to achieve this goal, the first step involved selection of appropriate physical components that would compromise of the basic elements of an active control system.

3.1 Overview

In order to implement a successful active control system, it was necessary to outline the basic system elements such as sensors, the controller system, and the actuating system. The mechanical system has to be as light as possible in order to make the scaled model behave as close as the actual building. In order to quantify the vibrations that are to be suppressed, and to develop an appropriate control response, an accurate depiction of the building motion must be available. The controller system must be able to interface with the sensors and interpret the building motion. It must then develop an appropriate control response based on this input, and output a response signal to the actuator. The actuating system must be capable of producing an appropriate physical response based on the output of the controller system to suppress vibration. Wind induced vibration is planned to be simulated in a wind tunnel. The aeroelastic model of the building will then have to be completed in order to allow for the wind tunnel test in an ulterior phase of the project. The model will have an appropriate skin laid on the tubing structure to mimic the exterior surfaces of the actual building.

A simple yet effective method of simulating wind induced vibrations in one direction was developed to satisfy the excitation requirements for this purpose [39]. An eccentric rotating mass, provided by a small DC motor (see Figure 2), was mounted rigidly on the top of the fifth floor plate. By slowly increasing the voltage input, the rotational frequency of the motor varied from 0 to 10Hz. This allowed for the simulation of a frequency sweep of the building excitation. By observing the displacement of the building over the duration of the frequency sweep, it was possible to identify the first mode natural frequency of the structure. Then, it was possible to provide the corresponding motor voltage. The observed behaviour of the building under the influence of this excitation was much more appropriate, as it had the proper 1st mode form, and was of sufficient displacement to be subjected to active control.



Figure 2 Excitation motor with eccentric mass

Sensors are used to quantify the motion of the model building. It was decided that the most appropriate method of sensing the motion of the building was through the use of strain gauges. Measurements Group EA-Series strain gauges were of an appropriate size for mounting to the model structure (approximately 1/4" x 1/8"). A minimum of two strain gauges was necessary to facilitate measurement of motion in both directions. The gauges were mounted on either side of one of the structural tubes near the base of the structure, where strain would be a maximum.

Specifications for the strain gauges chosen to be used for this project indicated that the resistance produced under strain would be $350.0 \pm 0.2\% \Omega$. This became the only constraint for the selection of a signal conditioner for the sensors. A Dataforth SCM5B38 signal conditioner was used which is capable of conditioning strain gauge resistance ranging from 100 to 10k Ω , which was appropriate for our application.

3.2 AMD Design

Another fundamental component of an active control system is a method of actuating the signal produced by the controller. It was decided that actuation would be achieved through the use of a DC motor that would control vibration in the plane of motion. A rack system was developed to house the motors and facilitate their linear motion. The motor was mounted to an aluminium base, which had a rod passing through it to allow the base to slide back and forth. The speed of the motor would be reduced using a planetary gear train, also mounted to the base, and the motor would move along the rack attached to the suspending structure. The rack was to be suspended from the fifth floor plate of the model. In anticipation of the need for position feedback in the control system, a Bourns 3590 Precision Potentiometer was used which varies resistance between the reference terminals from 0 to 10k Ω . An input voltage of 5 volts was used to power the potentiometer.

In order to implement the motor into the controller system, it was necessary to be able to easily quantify the motor constants, i.e. back EMF constant (K_b), torque constant (K_m), resistance (R), inertia (J), inductance (L), and the stall torque. This became the only constraint on the selection of the motor. A RE-260RA motor produced by Mabuchi Motor Co., was chosen. A planetary gear reduction of 20:1 was used to reduce the speed of the motor. A spur gear was placed on the output shaft of the motor to mesh with the rack on the suspension structure, and the motor and gear train were mounted to the aluminium base. At this point, the actuator was ready to be mounted to the building. The completed and mounted actuator system is shown below in Figure 3. In order to amplify the signal from the controller system to the motor actuator system, a Model 12A8E Series 25 servo amplifier (Advanced Motion Controls) was used.

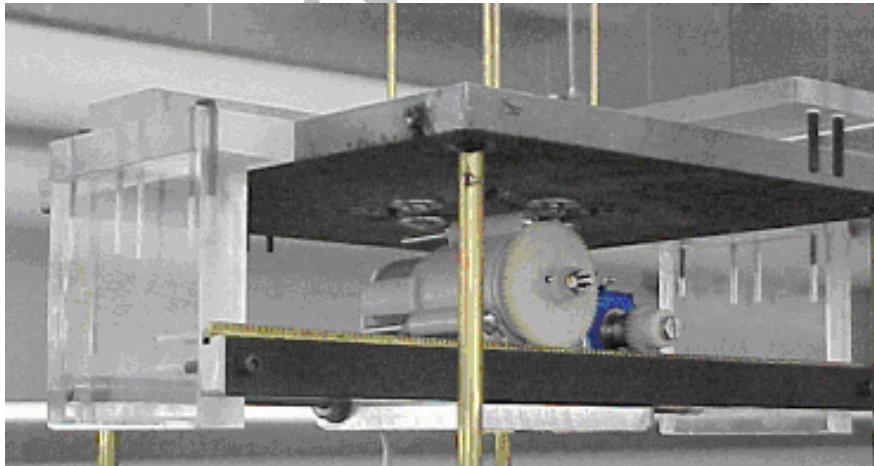

Figure 3 Final actuator system

3.3 Control Configuration

The five story lumped parameter model was modeled as a cantilever beam exhibiting planar vibration. In this work, the goal is to implement a Linear Coupling Control (LCC) strategy to eliminate the vibrations. This method was initially developed by Golnaraghi [40], and then generalized by Tuer [41] (see Figure 4). In this study the plant is a second-order system of the form

$$\ddot{u}_p + 2\zeta_p\omega_p\dot{u}_p + \omega_p u_p = V + F(t) \quad (7)$$

where ω_p is the plant natural frequency, u is a general function representing the control signal, and $F(t)$ is a forcing or a disturbance input. For a cantilever beam model such as that studied here, each mode of vibration can be represented by an ordinary differential equation (ODE) similar to (7) [42]. Using superposition, it is reasonable to assume that a control strategy can be implemented as a superposition of the control for each of the modes. Hence, the control method developed for a single mode of oscillation may be applied to other modes. A successful control strategy [40-42] incorporates a virtual system of the form

$$\ddot{u}_c + 2\zeta_c\omega_c\dot{u}_c + \omega_c u_c = \gamma_p M_p(u_p, \dot{u}_p, \ddot{u}_p, t) \quad (8)$$

where $u(t)$ is a time-dependent generalized controller co-ordinate, ζ_c is the controller damping ratio, ω_c is the controller natural frequency, and V is a generalized forcing input which is a linear function of plant states acceleration, velocity, or position and is proportional the parametric gain γ_p . In this method, the control input V in (1) is defined as

$$V = \gamma_c M_c(u_c, \dot{u}_c, \ddot{u}_c, t) \quad (9)$$

where $M_p(u_p, \dot{u}_p, \ddot{u}_p, t)$ is a linear function of the controller states and is proportional to the parametric gain γ_c . In the LCC technique, there are up to nine possible couplings [42]. Six of these are complementary pairs; for example, the coupling between controller velocity and plant position has similar characteristics to the coupling of controller position and plant velocity. By means of iterating, the optimum linear coupling combinations of the plant and the controller states, for the best energy exchange can be determined [43]. Based on the LCC approach, the following pair is found:

$$\begin{aligned} M_c(u_c, \dot{u}_c, \ddot{u}_c, t) &= \alpha u_c + \beta \dot{u}_c + \gamma \ddot{u}_c, \\ M_p(u_p, \dot{u}_p, \ddot{u}_p, t) &= \alpha u_p + \beta \dot{u}_p + \gamma \ddot{u}_p. \end{aligned} \quad (10)$$

where α , β , and γ are determined from the coupling terms in the governing equations of motion and the added control. The principal frequency of the building model, ω_p , and the damping ratio, ζ_p , determine the nature of the system response. The natural frequency of the system, including the controller device, was experimentally found to be 13.95 rad/s (2.22 Hz). The damping ratio, ζ_p , is calculated using the logarithmic decrement of the structure. This allowed for a displacement response to be implemented in order to determine the damping ratio. The decrement was calculated to be $\delta=0.04368$ and the damping ratio, ζ_p was determined to be

0.00695.

Once the values for these parameters were obtained, the second step was to determine the controller first natural frequency and the damping ratio, ω_C and ζ_C , respectively. First, it was assumed that

$$\omega_C \cong \omega_P \tag{11}$$

Then, based on the similarity between the controller system in hand and the vibration absorber (see Inman (1994) [38]), and also monitoring the rate of exchange of energy between the plant and the controller [43], the controller damping ratio, ζ_P was determined. It was found to be almost the same as that of the building model ($\zeta_P=0.00695$). For this particular system, the motor constants K_m and K_b , were calculated using the motor specifications. The motor constant K_m was calculated to be almost equal (as expected in SI units) 1.91×10^{-3} N-m/A and the back EMF constant, K_b , was determined to be equal 2.27×10^{-3} V/rad/s. The resistance of the motor was measured across its terminals and was found to be 2.8Ω . The motor inductance was also measured and was found to be 0.332 mH (which was considered small enough to be neglected). The motor inertia, J , was determined to be 3.612×10^{-5} kg-m². The required controller values were then evaluated using (5).

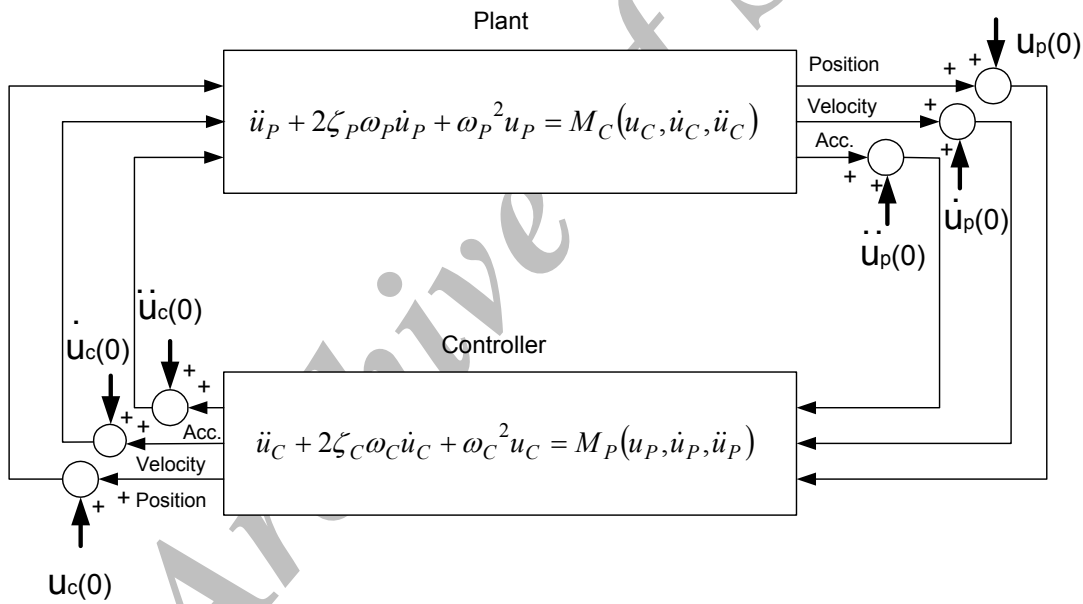

Figure 4 Diagrammatic/schematic illustration of the Linear Coupling Control (LCC) strategy used in the present work

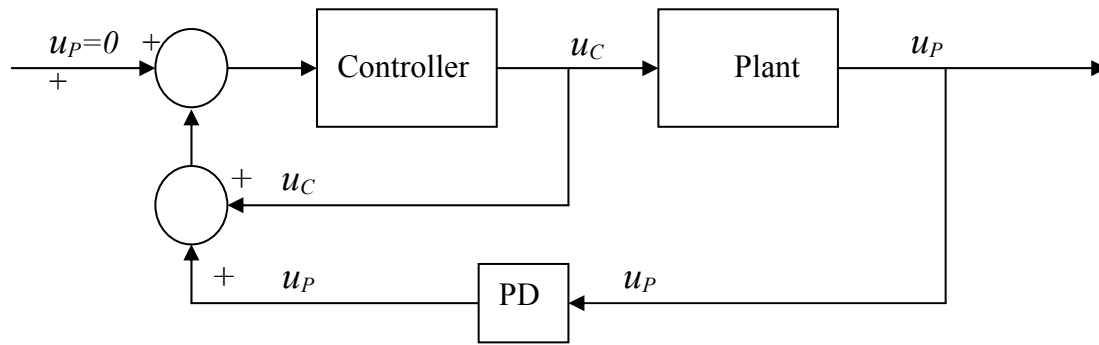

Figure 5 Simplified block diagram of the Linear Coupling Control (LCC) strategy used in the present paper

4. ACTIVE PENDULUM DAMPER (APD) DESIGN

An alternative active pendulum damper (APD) was also designed and implemented experimentally. The main purpose of this part was to verify if it was possible to develop a more effective control system to suppress the building's 1st mode vibrations by decreasing the total weight of the actuator system, the weight of the pendulum, and improving the vibration attenuation.

The idea was based on a coupled two-pendulum system where the building is modeled as a long pendulum and the absorber as a second pendulum. The building has higher inertia but a very small angle of vibration (maximum of 0.73° , 25mm displacement each side). Since the pendulum actuator has very small mass and short length compared to the building, the pendulum has to oscillate with a large angle (up to 90°) to control the vibration effectively. The vibration was assumed to be sinusoidal.

The controller design in this case is identical to the previous case and is not discussed in detail (see equations 10 and 11). The same type of motor, as in the previous design, was used and the armature resistance (R) was measured across the motor contacts and was found to be 1.5Ω . The controller constants, K_p and K_b , were then calculated following the same approach as previously used for the AMD controller. The remaining parameters were determined experimentally. The results are shown in Table 2.

As in the AMD controller, a potentiometer was coupled to the pendulum system to centre the pendulum when the building does not vibrate. The output signal from this controller was added to the output signal from the first PD controller and these two signals were combined and sent to the actuator. Therefore, the signal of the potentiometer should be very small compared to the building signal but high enough to centre the pendulum when building does not vibrate. The completed and mounted actuator system is shown in Figure 7.

5. EXPERIMENTAL RESULTS

5.1 AMD Control

A 3600-degree range potentiometer was installed on the actuator such that the actuator position with respect to the building centre could be detected. The output signal from this controller was added to the output signal from a PD controller and these two signals were combined and sent to the actuator (see Eqs. 10 and Figure 5). By combining these signals, the actuator could now absorb the building vibration by oscillating about the building centre.

With the controller turned off, the building was next excited at its first mode until displacement amplitude deemed sufficient to warrant vibration control. At this point the controller was activated, and the motor immediately responded to the motion of the building. It began with a large displacement in the direction opposite to the building at that particular moment, and the amplitude of the building displacement was immediately reduced by a considerable amount. Building displacement versus time is shown in Figure 6 during a system test. The figure includes the motion of the building before and after activation of the control system. This graph demonstrates the successful reduction of the building displacement by approximately 67%.

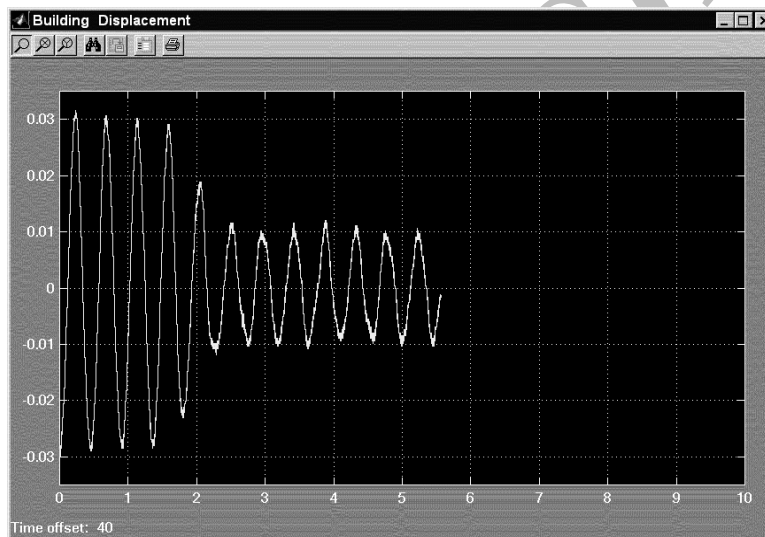

Figure 6 Building Displacement with AMD Control

5.2 APD Results

Two different control systems based on the PD and delay control, as mentioned before, were tested and results are shown in Figure 8. The two systems show the same results and could reduce 90% of the maximum building displacement in 12 cycles. It took about 6 cycles to reduce 60% of the maximum displacement. Comparing the APD and AMD controllers, the pendulum system takes more time to reach the same (60%) reduction than the moving mass. It can be attributed to the pendulum weight, which is only a half of the AMD. It can be concluded that since the pendulum system has smaller inertia, therefore it takes more time to attenuate the building vibration. The Results of all three systems are shown in Table 3. Since the maximum theoretical displacement that the model building can have is assumed to be equal to 0.025m, this

value was used to calculate the percentage reduction.

Table 2 Characteristics of the pendulum system

Parameter.	Value	Unit	Description
K_b	0.0392	Nm/A	Back EMF constant
K_m	0.0392	Nm/A	Torque constant
B	0.004957	[-]	Damping coefficient
R	1.5	Ω	Resistance
J	0.001363	kg/m ⁴	Inertia

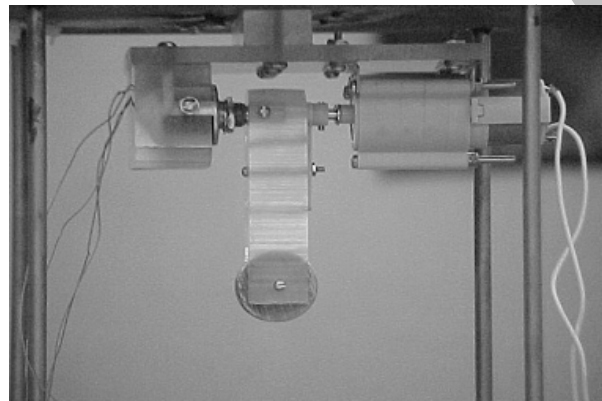

Figure 7 APD Control System

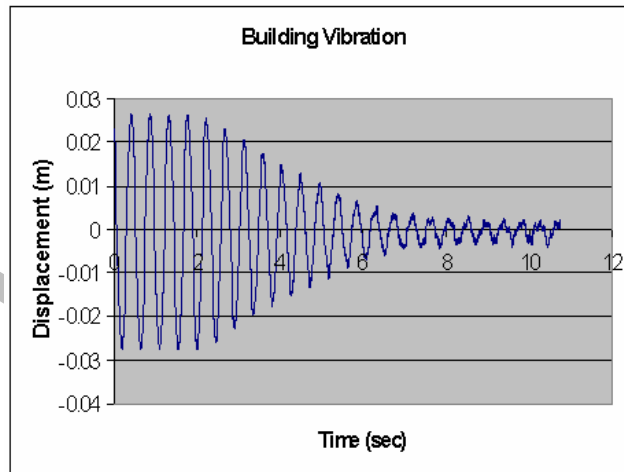

Figure 8 Damped Building Vibration Using APD and a PD Control

Table 3 Comparison between AMD and APD controllers

Parameter	Control System	
	AMD	APD
Max. Amplitude (allowed)	0.025	0.0253
Maximum Amplitude	0.03	0.0253
Minimum Amplitude	0.01	0.002404
Reduction	60%	90.38%
Number of cycle	2	12

6. CONCLNSIONS

The active control of wind-induced building vibration was addressed. A five-story aeroelastic lumped mass scaled model of a tall building was designed and was used as the test bed for the active control system. Simulating the wind forces as sinusoidal external forces, an active mass damper (AMD) was first designed and experimentally implemented to investigate the controlling the first mode vibration of the system. The preliminary design of an active pendulum damper (APD) system was then studied. The two systems were then experimentally compared and it was found that the AMD, being heavier and providing more inertia, could reduce 60% of the maximum building displacements in two cycles. The APD, incorporating smaller mass and inertia effect, could reduce 90% of the building displacement but in longer time (12 cycles). Improving the pendulum design and increasing its inertia, it will be possible to further increase the system effectiveness. It was also observed that activating different controllers, the building vibration could not reach zero steady state (zero displacement). This fact can be attributed to the small backlashes in the gearbox system used for speed reduction.

Acknowledgment: The authors wish to acknowledge Mr. Brian Breukelman, Dr. Peter Irwin and Mr. Scott Gamble from Rowan Williams Davies & Irwin (RWDI) Inc, for their advice and kind support. The authors also wish to thank Landy Toth, Gregory Bourne, Corey Kinart and Peter Won, mechanical engineering students for their assistance. This research was supported in part by NSERC and the MMO connections program.

REFERENCES

1. Simiu, E., and Scalman R.H., “*Wind effects on structures: Fundamentals and applications to design*”, 3rd edition (John Wiley and Sons Inc.) Toronto, 1996.
2. Tamura, Y., Fujii, K., Ohtsuki, T., Wakahara, T., and Kohsaka, R., Effectiveness of

- Tuned Liquid Dampers Under Wind Excitation, *Engineering Structures*, 17(9)(1995) 609-621.
3. Modi, V. J., Welt, F., and Seto, M. L., Control of Wind-induced Instabilities Through Application of Nutation Dampers: A Brief Overview, *Engineering Structures*, 17(9)(1995) 626-638.
 4. Kwok K. C. S., and Samali, B., Performance of Tuned Mass Dampers Under Wind Loads, *Engineering Structures*, 17(9)(1995) 655-667.
 5. Kareem, A., and Sun, W. J., Stochastic Response of Structures with Fluid-containing Appendages, *Journal of Sound and Vibration*, 19(3)(1987) 345-354.
 6. Fediw, A. A., Isyumov, N., and Vickery, B. J., Performance of a Tuned Sloshing Water Damper, *Journal of Wind Engineering and Industrial Aerodynamics*, 57(1995) 237-247.
 7. Livesey, F. and Sendergaard, T., Verification of the Effectiveness of TMDs Using Wind Tunnel Section Model, *Journal of Wind Engineering and Industrial Aerodynamics*, 64(1996) 161-170.
 8. Tamura, Y., Kohaska, R., Nakamura, O., Miyashita, K., and Modi, V. J., Wind-induced Response of an Airport Tower-Efficiency of Tuned Liquid Damper, *Journal of Wind Engineering and Industrial Aerodynamics*, 65(1996) 121-131.
 9. Modi, V. J., and Seto, M. L., Suppression of Flow-induced Oscillations Using Sloshing Dampers: Analysis and Experiments, *Journal of Wind Engineering and Industrial Aerodynamics*, 67& 68(1996) 611-625.
 10. Balendra, T., Wang, C. M., and Cheong, H. F., Effectiveness of Tuned Liquid Dampers for Vibration Control of Towers, *Engineering Structures*, 17(9)(1995) 668-675.
 11. Reed, D., Yeh, Harry, Yu, J., and Gardarsson, S., Tuned Liquid Dampers Under Large Amplitude Excitation, *Journal of Wind Engineering and Industrial Aerodynamics*, 74&76(1998) 923-930.
 12. Ankireddi, S. and Yang, H. T. Y., Directional Mass Dampers for Buildings Under Wind or Seismic Loads, *Journal of Wind Engineering and Industrial Aerodynamics*, 65(2000) 119-144.
 13. Chang, C. C., and Hsu, C. T., 1998, Control Performance of Liquid Column Vibration Absorbers, *Engineering Structures*, 20(7)(1998) 580-586.
 14. Hitchcock, P. A., Glanville, M. J., Kwok, K.C.S., Watkins, R. D., and Samali, B., Damping Properties and Wind-induced Response of a Steel Frame Tower Fitted with Liquid Column Vibration Absorbers, *Journal of Wind Engineering and Industrial Aerodynamics*, 83(1999) 183-196.
 15. Balendra, T., Wang, C. M. and Rakesh, G., Vibration Control of Various Types of Buildings Using TLCD, *Journal of Wind Engineering and Industrial Aerodynamics*, 83(1999) 197-208.
 16. Balendra, T., Wang, C. M. and Rakesh, G., Effectiveness of TLCD on Various Structural Systems, *Engineering Structures*, 21(1999) 291-305.
 17. Gao, H. Kwok, K. S. C. and Samali, B., Characteristics of Multiple Tuned Liquid Column Dampers in Suppressing Structural Vibration, *Engineering Structures*,

- 21(1999) 316-331.
18. Chang, C. C., "Mass dampers and their optimal design for building vibration control", *Engineering Structures*, 21(1999) 454-463.
 19. Rena, R., and Soong, T. T., "Parametric study and simplified design of tuned mass dampers", *Engineering Structures*, 20(3)(1998) 193-204.
 20. Xue, S. D., Ko, J. M. and Xu, Y. L., "Tuned Liquid Column Damper for Suppressing Pitching Motion of Structures", *Engineering Structures*, 23(2000) 1538-1551.
 21. Lin, C-C, Uneg, J-M and Huang, T-C, "Seismic response reduction of irregular buildings using passive tuned mass dampers", *Engineering Structures*, 22(1999) 513-524.
 22. Koss, L. L., and Melbourne, W. H., "Chain dampers for control of wind-induced vibration of tower and mast Structures, *Engineering Structures*, 17(9)(1995) 622-625.
 23. Samali, B., and Kwok, K. C. S., 1995, Use of Viscoelastic Dampers in Reducing Wind- and earthquake-induced Motion of Building Structures, *Engineering Structures*, 17(9)(1995) 639-654.
 24. Ogawa, K., Ide, T. and Satiou, T., Application of Impact Mass Damper to a Cable-stayed Bridge Pylon, *Journal of Wind Engineering and Industrial Aerodynamics*, 72(1997) 301-312.
 25. Kubo, Y., Modi, V. J., Kotsubo, C., Hayashida, K., and Kato, K., Suppression of Wind-induced Vibrations of Tall Structures Through Moving Surface Boundary-layer Control, *Journal of Wind Engineering and Industrial Aerodynamics*, 61(1996) 181-194.
 26. Ricciardelli, F., Occhiuzzi, A. and Clemente, P., Semi-active Tuned Mass Damper Control Strategy for Wind-excited Structures, *Journal of Wind Engineering and Industrial Aerodynamics*, 88(2000) 57-74.
 27. Facioni, R. J., Kwok, K.S.C. and Samali, B., Wind Tunnel Investigation of Active Vibration Control of Tall Buildings, *Journal of Wind Engineering and Industrial Aerodynamics*, 54/55(1995) 397-412.
 28. Xu, Y. L., Parametric Study of Active Mass Dampers for Wind-excited Tall Buildings, *Engineering Structures*, 18(1)(1996) 64-76.
 29. Yang, J. N., Wu, J. C. and Li, Z., Control of Seismic-excited Buildings Using Active Variable Stiffness System, *Engineering Structures*, 18(8)(1997) 589-596.
 30. Mackriell, L. E., Kwok, K. S. C. and Samali, B., Critical Modes Control of a Wind-Loaded Tall Building Using an Active Tuned Mass Damper, *Engineering Structures*, 19(10)(1997). 834-842.
 31. Chang, P-M, Lou, J. K. and Lutes, L. D., Model Identification and Control of a Tuned Liquid Damper, *Engineering Structures*, 20(3) (1998) 155-163.
 32. Cao, H., Reinhorn, A. M. and Soong, T. T., Design of an Active Mass Damper for a Tall TV Tower in Nanjing, China, *Engineering Structures*, 20(3)(1998) 134-143.
 33. Battaini, M., Breitung, K., Casciati, F. and Faravelli, L., Active Control and Reliability of a Structure Under Wind Excitation, *Journal of Wind Engineering and*

- Industrial Aerodynamics*, 74-76(1998) 1047-1055.
34. Tamura, Y., Application of Damping Devices to Suppress Wind-induced responses of Buildings, *Journal of Wind Engineering and Industrial Aerodynamics*, 74-76(1998) 49-72.
 35. Gupta, H., Soong, T. T. and Dargush, G. F., Active Aerodynamic Bidirectional Control of Structures I: Modeling and Experiments, *Engineering Structures*, 22(2000), 379-388.
 36. Gupta, H., Soong, T. T. and Dargush, G. F., Active Aerodynamic Bidirectional Control of Structures II: Tall Buildings, *Engineering Structures*, 22(2000) 389-399, 2000.
 37. Toth, L., *Active Control of Building Vibration Due to Wind and Seismic Loading, Phase I: Design of an Aeroelastic Model for Wind Tunnel Testing*, Internal Report, Dept of Mech. Eng. (University of Waterloo) Waterloo, Canada, 2000.
 38. Inman D. J., *Engineering Vibration* (Prentice Hall Inc) 1994.
 39. Bourne G. and Kinart C., *Active Control of Building Vibration Due to Wind and Seismic Loading, Phase II: Design and Implementation of an Active Control System*, Internal Report, Dept of Mech. Eng., (University of Waterloo) Waterloo, Canada, 2000.
 40. Tuer, K. L., *Towards the Formulation of Generalized Vibration Suppression Law Using Linear and Nonlinear Coupling Paradigms*, PhD Thesis (University of Waterloo) Canada, 1994.
 41. Golnaraghi M. F., Regulation of Flexible Structure Via Nonlinear Coupling, *J. Dyn. Control*, 1(1991) 405-428.
 42. Young H. L., *Beating Vibrations to Death*, Master's Thesis (University of Waterloo) Canada, 1996.
 43. Fariborzi, F., Golnaraghi, M. F. and Heppler, G. R., Experimental Control of Free and Forced Structural Vibration Using a Linear Coupling Strategy, *Smart Mater. Struct.*, 6(1997) 540-548.