

EFFECT OF OPENING DIMENSIONS ON THE RELATIVE FLEXURAL OPERATION OF COUPLED SHEAR WALLS

M.E. Torki Harcheganiu^a, B. Talaei Taba^b and F. Farahbod^{*c}

^aDepartment of Civil Engineering, Sharif University of Technology, Tehran, Iran

^bDepartment of Civil Engineering, Isfahan University of Technology, Isfahan, Iran

^cDepartment of Structural Engineering, Building and Housing Research Center, Tehran, Iran

Received: 10 January 2011; **Accepted:** 5 September 2011

ABSTRACT

Effect of openings' dimensions on the relative flexural behavior of adjacent piers (independent or conjugate) in perforated shear walls is addressed. 384 designed models were made and exposed to lateral loads. For middle openings, in addition to the alpha parameter in the literature, the relative flexural behavior of piers in medium-rise buildings can be predicted as function of thickness-to-length ratio of the coupling beam and the ratio of the coupling beam length to the pier length; but in high-rise buildings, it is always conjugate. For corner openings, the alpha parameter must be modified with respect to the number of stories.

Keywords: Perforated/coupled shear walls; relative flexural behavior; piers; story drift

1. INTRODUCTION

In many buildings, especially the ones fortified with large shear walls and those having central cores, engineers are persuaded to provide shear walls with openings. These openings induce different flexural and shear behaviors in the piers in comparison to the way single walls act under lateral loads. That is, the adjacent piers can behave flexurally independent or conjugate. The two behaviors are displayed in Figure 1.

Although researchers have developed various methods for analyzing (and designing) systems of coupled shear walls, quite a few have put forward relations between the dimensions of openings and the way the piers behave together, independent or conjugate. The difference between the two manners entails different ways of modeling the shear wall continuum. Namely, the two adjacent piers are modeled as two independent media in case of having flexurally independent behaviors and they are modeled, together with the connecting beam, as one single medium when the two piers act conjugate. This deeply influences the amount and array of reinforcement bars, especially around the openings [1]. While most of the time, the system is idealized so that the walls supposedly act independently, the true

* E-mail address of the corresponding author: f.farahbod@bhrc.ac.ir (F. Farahbod)

behavior is not always as assumed to be. This research deals with how the dimensions of openings affect the true relative behavior of the piers against flexure.

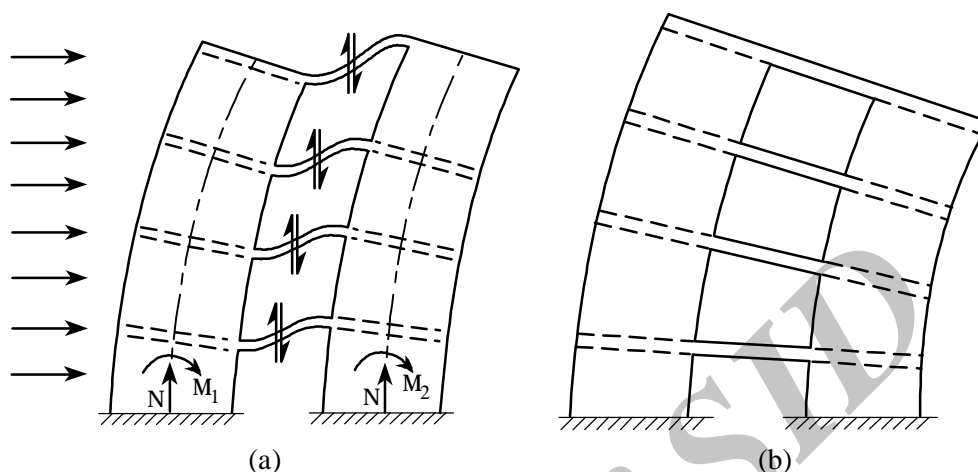

Figure 1. (a) Independent behavior of piers (b) Conjugate behavior of piers

If the shear rigidity of the walls or the height-to-width ratio of the piers is very large, then the relative flexural behavior of the walls is conjugate, and vice versa. In this case, the normal stress distribution in the piers is linear in the whole section, while in the other case the stress distribution deviates from this case, and two separate stress distributions will exist in the adjacent piers [2]. The relative flexural behavior of the walls is directly influenced by the number of stories, such that, in very low-rise or, as will be observed, very high-rise buildings, this relative behavior is always conjugate [3].

Many researchers have developed analytical or numerical methods to analyze (and mostly to design) coupled shear walls, most of which pertain to the independent manner of behavior in the two walls. For instance, of the first and foremost methods in analyzing coupled walls is the “*Continuous Medium*” method, primarily proposed by Timoshenko and followed up by others as Chitty, Mayer, Minnelli, etc. Among other old methods are the “*Equivalent Frame*” method, in which the piers and connecting beams are replaced with two-dimensional frame elements, and the finite-element method. The latter was primarily put forward by researchers such as Hrenikoff, McCormick, Turner et al., and Argyris [4]. More recently, multiple methods have been developed to analyze coupled shear walls in the elastic and elastoplastic forms, most of which correspond to the independent flexural behavior. Among the most popular works in this field are the methods proposed by Pisanty and Traum [5], Tso and Biswas [6], and Elsied et al. [7] for the elastic region, and the elastoplastic method developed by Pekau and Gocevski [8]. Also, a number of methods have been produced capable of analyzing coupled shear walls in both cases, i.e. in general case, such as those recommended by Capuani et al. [3], Koo and Cheung [2], and Lu and Chen [9]. Kwan developed a formula as function of geometric parameters of the coupled shear wall to calculate the error in estimating the effective stiffness of the connecting beam. When this error becomes large, the relative flexural behavior approaches the independent case [10]. Another geometric parameter to predict the relative flexural behavior of piers is expressed in Refs. [4-5].

The flexural behavior of perforated shear walls plays a substantial role in modeling these structural elements optimally, and distinguishing the hypertension places to fortify with stiffeners if necessary. Optimum design of single-cored shear walls subjected to combined effects of axial forces, bending, and torsional moments was developed by Al-Mosawi and Saka by considering the limit-state plastic analysis of the shear panel, using the total cross section area of reinforcement bars and that of the thin-walled structure of shear walls [11]. Hidalgo et al. developed an analytical model to predict the inelastic seismic response of coupled shear walls. Based on numerous experiments, the shear failure model was used to implement a computer program to evaluate the response of a building under severe ground motions [12]. Tarján and Kollár presented an approximate analysis to predict the earthquake responses of multistory building frames with lateral resisting subsystems such as coupled shear walls, frames, trusses, and cores. They introduced stories with equivalent stiffnesses and masses and considered coupled shear walls as equivalent continuous media plus coupling beams [13]. An efficient 2D finite-element model for the analysis of high-rise building with perforated shear walls was proposed by Kim and Lee. They used super elements consisting of plane elements and connecting beam elements to satisfy interface boundary conditions. They deduced that when the opening size becomes larger, this method will not have sufficient exactitude [14]. The same researchers put forward a 3D finite-element model for the analysis of high-rise building with perforated shear walls. They introduced super elements including 3D brick elements and fictitious link beams to satisfy interface boundary conditions. They asserted that this method significantly reduces the calculation work and gives most accurate results [15]. Due to the sensitivity of coupled shear walls towards lateral deformations, damage analysis of structures including coupled shear walls has received growing concern in recent years. Meftah and Tounsi presented a method by using mixed finite elements to evaluate the dynamic response of buildings containing coupled shear walls with damaged segments fortified with FRP sheets. They considered the effects of the damage extent as well as that of FRP sheets on the dynamic behavior of coupled shear walls [16].

As explored in the above literature review, to the best of the authors' knowledge, meager work has been dedicated to the estimation of relative flexural behavior of coupled walls, i.e. when they act flexurally independent or conjugate. In this paper, geometric parameters are introduced to predict the true relative behavior of the adjacent piers in two cases of openings placed at the middle and at the corner. The same parameters will prove efficacious for the case that the cross section of any of the two walls abruptly changes in elevation.

2. METHODOLOGY

2.1 Geometric Criteria

As stated in the introduction, there are few geometric properties to determine the relative flexural behavior of coupled shear walls. One of the geometric parameters stated in the literature is Kwan's formula to calculate the error in estimating the effective stiffness of the connecting beam [10]:

$$error = \frac{(b/Gth)}{(b^3/12EI) + (b/GA') + (b/Gth)} \quad (1)$$

where E , G , A , A' , t , and I are the pier Young's modulus, shear modulus, cross sectional area, equivalent shear cross sectional area, thickness, moment of inertia, respectively; b is the net span length of the connecting beam, and h is the story height. He proved that in the case the relative flexural behavior of the piers approaches the independent manner, i.e. in the case of having large openings, this error gets larger, even more than 40%, and when the opening is relatively small, it becomes smaller. This can be used as a criterion to predict the relative flexural behavior of the walls.

The most well-known equation to predict the relative flexural behavior of the walls is the geometric parameter α , as indicated in Eq. (2) Refs. ([4, 5]):

$$\alpha = \sqrt{\frac{12I_b}{hb^3} \left(\frac{\mathbf{l}^2}{I_{c1} + I_{c2}} + \frac{A_{c1} + A_{c2}}{A_{c1}A_{c2}} \right)} \quad (2)$$

where H is the total height of the building, I_b is the moment of inertia of the connecting beam, h is the story height, b is the net span length of the connecting beam, \mathbf{l} is the distance between the centroidal axes of piers, I_{c1} and I_{c2} are area moments of inertia of the two piers, and A_{c1} and A_{c2} are cross section areas of the two piers. In cases where αH is a large amount, e.g. greater than 8, the two walls act conjugate, and when it is very low, e.g. lower than 4, they act independently [4].

In the present research, the relative flexural behavior of the two piers is identified using four key points A , B , C , and D , as demonstrated in Figure 2. Since the system of coupled shear walls is in fact flexible, in the case that the relative behavior of piers is independent, a contraflexure point occurs almost at the middle of the connecting beam (this is the basis of most approximate methods) [17]. In this case, the vertical displacements of points A and C are not far different in amount, and therefore the final locations of these two points are almost at the same elevation. All the same, in the case that the relative behavior is conjugate, the four points stand on a (somehow) straight inclined line. The schematic behavior of the displacements of the four key-points is shown in Figure 2. In the present research, points C and D will coincide in the case the opening is placed at the corner.

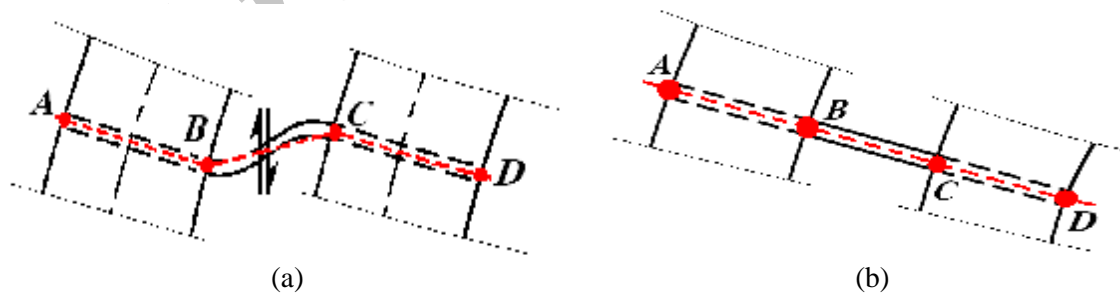

Figure 2. The schematic behavior of the displacements of the four key-points, (a) In the case of independent behavior, (b) In the case of conjugate behavior

If each pier is considered to be a deep beam, it can easily be observed that the displacement of the four key points A , B , C , and D can be best evaluated in the story with the *maximum drift*. In most buildings, there is one turning point of lateral story displacements,

and therefore one extremum point of story drifts along the elevation axis, as demonstrated in Figure 3.

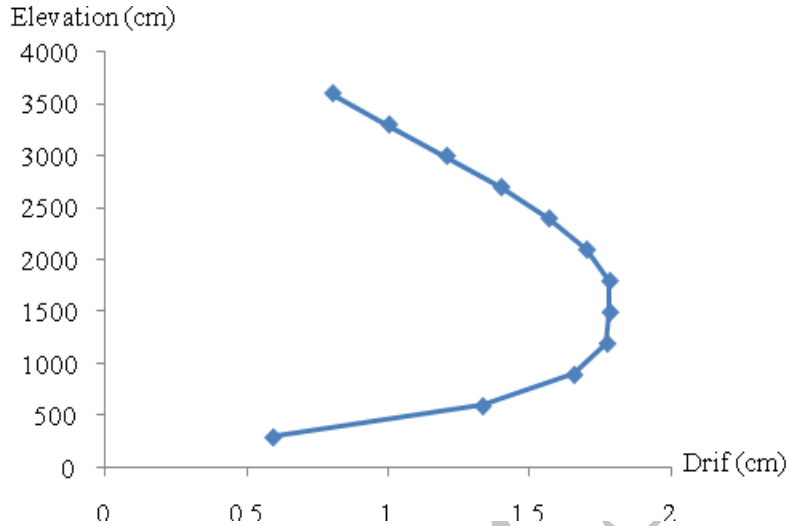

Figure 3. An example of story drifts of a building along the elevation axis

As far as geometry is concerned, many parameters can be used to evaluate the effect of the dimensions of the opening on the flexural relative behavior of walls. In this research, all possible *logical* parameters were examined, including I_1/I_w , I_1/h_1 , and $b = h_2/h_1$. The first two ratios did not prove able to evaluate the relative behavior of the walls in the extreme cases, i.e. when the ratios are rather great or small, whereas the last ratio, β is quite proper for this purpose. The corresponding dimensions are shown in Figure 4.

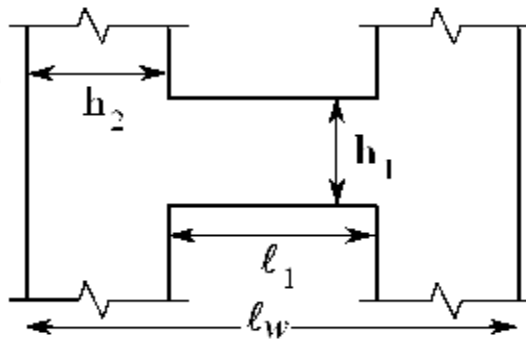

Figure 4. The corresponding dimensions of the geometric ratios used to evaluate the relative behavior of walls

On the other hand, β does not suffice since one other dimension or ratio must be to be introduced to completely determine the outline of the system. Thus, in addition to β , h_1 was also used as an independent variable, and the relative behavior of the adjacent walls was assessed using both β and h_1 as variables.

2.2 Modeling procedure

In order to evaluate the relative flexural operation of the coupled shear walls, the models were made with the following properties:

1. The models were 8, 12, 15, 20, 25, and 30-story buildings.
2. All structures were symmetric in plan and homogeneous in height.
3. The plans had 5 spans in both directions. The spans without shear walls were 6 m, and those with shear walls varied from 6 to 11 m.
4. The shear walls were placed at the second and fourth spans and in the two end axes of the plan, in both directions.
5. Since story heights are often constant throughout the elevation, the heights of all stories were considered to be 3.2 m.
6. The openings were considered to have two different formations: they were placed either at the middle or at the corner of the span. For the sake of simplicity in the latter case, there was supposed to be no distance between the opening end and the column. The two formations are depicted in Figure 5.

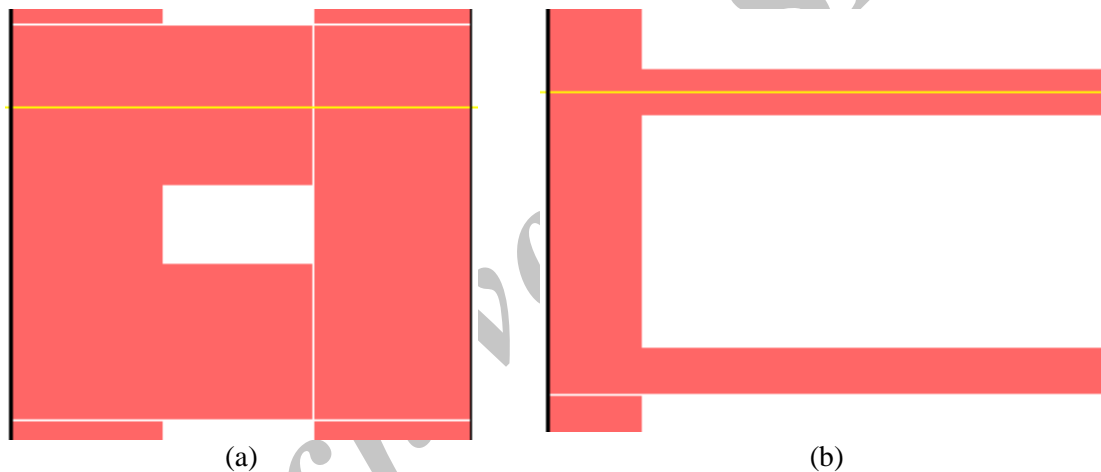

Figure 5. Placement of the opening: (a) At the middle of the span, (b) At the corner of the span (with no distance between the opening end and the column)

1. In each model, one amount for h_l and one amount for β were considered. Altogether, the amounts assumed for h_l were $h_l = \{35, 50, 80, 100\} (cm)$, and the amounts assumed for β were $b = \{0.1, 0.15, 0.2, 0.25, 0.3, 0.4, 0.5, 0.7\}$. The models were made with permutations of N (number of stories), h_l , and β . Thus, the total number of models was:

$$\text{Total number of models} = 6 \text{ (6 series of story numbers)} \times 2 \text{ (2 manners of placing the openings)} \\ \times 4 \text{ (4 different amounts for } h_l) \times 8 \text{ (8 different amounts for } b) = 384$$

2. In each model, two shear walls were placed at each direction of the plan, and all spans were identical for the two directions. The thicknesses of the walls were taken to be constant throughout the elevation of the building.

3. The models were firstly analyzed and designed as far as the structural elements' reinforcements and story drifts were concerned, in conformity with ACI 318-05, using ETABS.
4. After analyzing and designing each model, the displacements of the four key points *A*, *B*, *C*, and *D* under lateral loads (caused by earthquake) along *Z* direction (denoting the elevations) were read from ETABS. If the displacements of *A* and *C*, and *B* and *D* were close in amount, the two piers were considered flexurally independent; otherwise, they were taken to be conjugate. Also, the story drifts were taken out, the elevation-drift diagrams were plotted, and the stories corresponding to the maximum drift were identified (there are mostly three consecutive stories which have almost the same drift equaling the maximum drift). An example of the story drifts and the key-points' displacement diagrams are shown in Figure 6.

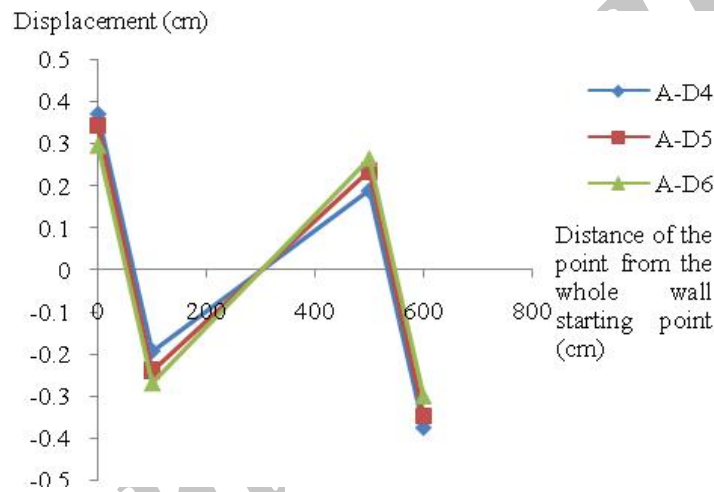

(a)

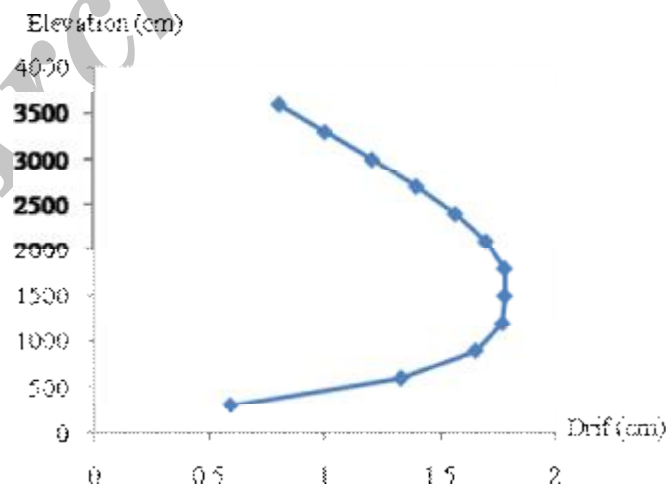

Figure 6. (a) Displacements of the key points under lateral loads in the stories with maximum drifts (signifying the independent relative behavior); (b) Story drifts along the elevation (*Z*) axis

3. RESULTS AND DISCUSSIONS

After the models were made and the corresponding diagrams were produced, the physical properties of the system, together with the derived relative flexural behaviors, were gathered in a spreadsheet. These properties include β and h_2 as independent variables, $h_1 = h_2/b$, α , I_2/I_w , and b/I_w . Then the relative flexural behavior of the piers was related to the proper quantity. The results obtained are as follows:

In the case of central openings, αH ([4-5]) does not predict the relative flexural behavior of the walls realistically for higher-than-8 story buildings. On the other hand, for lower-than-12 story buildings, the range put forward in Ref. [4] for αH (greater than 8 for acting conjugate and lower than 4 for acting independently) is conservative in relation to the *independent* flexural behavior of piers. Namely, some cases exist in which the walls act independently in reality while this relation estimates the relative behavior to be conjugate. An example of such a case is when β is 0.5. Data processing reveals that, in this case, the relative behavior of the walls can be to a better extent predicted using $h = b/I_w$, as follows:

For $N < 15$, only if β is around 0.3 and 0.5 (in fact $0.27 \leq b \leq 0.5$ or $0.47 \leq b \leq 0.53$), the relative behavior can be independent, and if β is out of this range, which takes up most of the cases, the relative behavior is conjugate. If β is around either 0.3 or 0.5, for $h > 0.6$, the relative behavior is independent (for the elevations equal to or greater than the elevation(s) with the maximum drift), and for $h \leq 0.6$ it is conjugate. Calculations performed on the relation in Ref. [4] demonstrate that if β is greater than 0.3, the relative behavior of the walls is conjugate in all circumstances. Thus, this relation does not predict the relative behavior of the walls realistically.

For $N \geq 15$, the relative behavior is always conjugate. Therefore, in case of having central openings, the relative behavior of the walls is conjugate in most cases.

In the case of corner openings, while $h = b/I_w$ cannot predict the relative flexural behavior of the walls realistically, α can better account for that.

If $b = h_1/h_2 \leq 0.3$, αH can well evaluate the relative behavior of the walls, such that:

For $N \leq 12$, if $\alpha H/h = \alpha N \leq 2 \times 10^{-2} \text{ cm}^{-1}$, the relative behavior of the walls is independent (for the elevations equal to or greater than the elevation(s) with the maximum drift), and if $\alpha N > 2 \times 10^{-2} \text{ cm}^{-1}$, the relative behavior is conjugate.

For $N > 12$, if $\alpha N \leq 3 \times 10^{-2} \text{ cm}^{-1}$, the relative behavior of the walls is independent (for the elevations equal to or greater than the elevation(s) with the maximum drift), and if $\alpha N > 3 \times 10^{-2} \text{ cm}^{-1}$, the relative behavior is conjugate.

If $b = h_1/h_2 > 0.3$, αH cannot well evaluate the relative behavior of the walls because calculations on αH show that if $b = h_1/h_2 > 0.3$, under no circumstances can the two walls act independently. Thus, αH can no more be valid. Data processing on the models reveals that, in this case, instead of αH , α/H is more rational, such that:

For $N < 30$, if $\alpha h/H = \alpha/N < 2 \times 10^{-4} \text{ cm}^{-1}$, the relative behavior of the walls is independent (for the elevations equal to or greater than the elevation(s) with the maximum drift), and if $\alpha/N \geq 2 \times 10^{-4} \text{ cm}^{-1}$, the relative behavior is conjugate.

For $N > 30$, in all cases the relative behavior of the walls is conjugate.

Consequently, the number of stories, N , has a greater effect on the relative behavior of the walls in the case of having central openings, than in the case the openings are placed at the corner.

Comparison among the story-drift diagrams for high-rise buildings, i.e. with more than 12 stories, demonstrates that, when h_l increases, with a constant β , the turning point of lateral story displacements, i.e. the extremum of story drifts, occurs in a higher elevation. This is due to the direct effect of the connecting beam on the lateral stiffness of the system, which induces a cantilever behavior on the coupled system, causing the turning point to shift upward. However, this effect decreases when N gets increased. Namely, with increasing N , the amount of h_l to shift the turning point upward gets inclined. A comparison of the extrema of story drifts for a 20-story building for the case of lateral openings is shown in Figure 7.

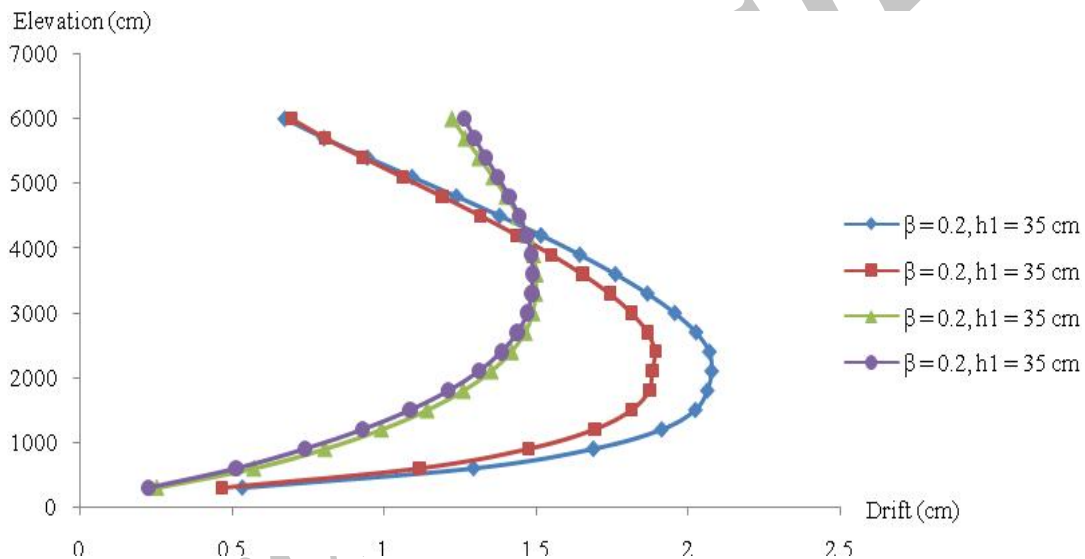

Figure 7. A comparison of the extrema of story drifts for a 20-story building for the case of lateral openings

4. CONCLUSIONS

In the present research, the effects of different geometric parameters on the relative flexural behavior of coupled shear walls were examined in order to predict the flexurally independent and conjugate behaviors precisely. To do so, 384 models were made, analyzed, and designed in ETABS, and each parameter was varied in a number of models. From each model, story drifts and the lateral displacements of the four key points on the shear wall in the stories with highest drifts were extracted. The results obtained are as follows:

- The relative flexural behavior of coupled shear walls significantly depends on the number of stories (N), the ratio of the connecting beam height to the pier width (β), and the connecting beam height itself (h_l).

- To evaluate the relative flexural behavior of the adjacent piers, depending on the circumstances of β and N , the relative flexural behavior can be related to one of the quantities including $h = b/l_w$, aH/h , and ah/H .
- If the openings are placed at the middle, aH relation predicts the relative flexural behavior of the walls erroneously for higher-than-8 story buildings. Moreover, for lower-than-12 story buildings, the range put forward in Ref. (MacLeod 1970) for aH is conservative as far as the *independent* flexural behavior of piers is concerned, such that in some cases where the walls actually conduct independently, Ref. [4] estimates the relative behavior to be conjugate. Data processing revealed that $h = b/l_w$ can better estimate the relative flexural behavior of the walls in this case.
- If the openings are placed at the corner, a relation can be better applicable to evaluate the relative behavior of the walls, such that, for $b = h_1/h_2$ up to 0.3, aH and for β greater than 0.3, a/H is more accountable to determine the relative behavior of the walls.
- In both types of opening placing, when N , the number of stories gets increased, the relative flexural behavior of the walls approaches the conjugate manner, such that, in the case of middle openings, for $N \geq 15$, and in the case of corner openings, for $N > 30$, the relative flexural behavior of the walls is conjugate in all cases.
- In high-rise buildings, when h_1 increases and β is constant, the story with the maximum drift shifts upward due to the fact that thick connecting beams make the system more laterally stiff and causes the overall behavior of the system to approach that of a cantilever.

Acknowledgments: This is to certify and appreciate that all achievements in the present research were financially supported by “Faratarh Ariana” consulting and supervising corporation in Isfahan.

REFERENCES

1. Vecchio FJ, Chan CCL. Reinforced concrete membrane elements with perforations, *Journal of Structural Engineering*, No. 9, **116**(1990) 2344-60.
2. Koo KK, Cheung YK. The static analysis of multi-bay coupled shear walls, *Building and Environment*, No. 2, **19**(1984) 93-9.
3. Capuani D, Merli M, Savoia M. An equivalent continuum approach for coupled shear walls, *Journal of Engineering Structure*, No. 1, **16**(1994) 63-73.
4. MacLeod IA. Shear Wall-Frame Interaction, *Portland Cement Association*, 1970.
5. Pisanty A, Traum EE. Simplified analysis of coupled shear walls of variable cross-section, *Journal of Building and Science*, **5**(1970) 11-20.
6. Tso, W. K. and Biswas, J. K. An approximate seismic analysis of coupled shear walls, *Journal of Building and Science*, **7**(1972) 249-56.
7. Elsieid, A., Ragab, A., and Emam, H. M. Dynamic behavior of coupled shear wall through analytical models, *Journal of Computers and Structures*, No. 2, **35** (1990) 183-7.

8. Pekau, O. A. and Gocevski, V. Elasto-plastic analysis of coupled shear walls, *Journal of Engineering Structures*, **3**(1981) 87-95.
9. Lu, X. and Chen, Y. 2005. Modeling of Coupled Shear Walls and Its Experimental Verification, *Journal of Structural Engineering*, No.1, **131**(2005) 75-84.
10. Aksogan, O., Arslan, H. M., and Choo, B. S. Forced Vibration Analysis of Stiffened Coupled Shear Walls Using Continuous Connection Method, *Journal of Engineering Structures*, **25** (2003) 499–506.
11. Al-Mosawi, S. S. and Saka, M. P. Optimum Design of Single-Core Shear Walls, *Journal of Computers and Structures*, **71**(1999) 143-62.
12. Hidalgo, P. A., Jordan, R. M., and Martinez, M. P. An Analytical Model to Predict the Inelastic Seismic Behavior of Shear Wall Reinforced Concrete Structures, *Journal of Engineering Structures*, **24** (2002) 85-98.
13. Tarján, G. and Kollár, L. P. Approximate Analysis of Building Structures with Identical Stories Subjected to Earthquakes, *International Journal of Solids and Structures*, **41**(2004) 1411–33.
14. Kim, H. S. and Lee, D. G. Analysis of Shear Walls with Openings using Super Elements, *Journal of Engineering Structures*, **25** (2003) 981-91.
15. Kim, H. S., Lee, D. G., and Kim, C. K. Efficient Three-Dimensional Analysis of a High-Rise Building Structure with Shear Walls, *Journal of Engineering Structures*, **27**(2005) 963-76.
16. Meftah, S. A. and Tounsi, A. Lateral Stiffness and Vibration Characteristics of Damaged RC Coupled Shear Walls Strengthened with Thin Composite Plates, *Journal of Building and Environment*, **42** (2007) 3596–605.
17. Choudhury, J. R. *Analysis of Plane and Special Systems of Interconnected Shear Walls*, A Thesis Presented for the Degree of Doctor of Philosophy, Faculty of Engineering and Applied Science, University of Southampton, 1968.