



Technical Note

**FINITE ELEMENT ANALYSIS OF FRP STRENGTHENED RC
BEAMS USING ANSYS**

P. Jayajothi,* R. Kumutha and K. Vijai

Department of Civil Engineering (PG), Sona College of Technology, Salem, India

Received: 10 October 2012; **Accepted:** 8 February 2013

ABSTRACT

This paper presents the nonlinear Finite Element Analysis (FEA) that has been carried out to simulate the behaviour of failure modes of Reinforced Concrete (RC) beams strengthened in flexure and shear by Fibre Reinforced Polymer (FRP) laminates. Four beams were modelled in FEM software using ANSYS. In those four beams, two beams were control beams without FRP and other two beams were Carbon Fibre Reinforced Polymer (CFRP) strengthened beams. A quarter of the full beam was used for modelling by taking advantage of the symmetry of the beam, loading and boundary conditions. From the analyses the load deflection relationships until failure, and crack patterns were obtained and compared with the experimental results available in the Literatures. The load deflection plots obtained from numerical studies show good agreement with the experimental plots reported by Balamuralikrishnan & Antony Jeyasehar, and Amer M. Ibrahim & Mohammed Sh. Mahmood. There was a difference in behaviour between the RC beams strengthened with and without CFRP layers. The crack patterns obtained in FEA in the beams were also presented. The use of computer software to model these elements is much faster, and extremely cost-effective. Therefore, modelling of experimental beams can be adoptable in ANSYS. Validation of experimental results can also be done using ANSYS.

Keywords: Fibre Reinforced Polymer; finite element Analysis; ANSYS; CFRP; modelling; crack patterns

1. INTRODUCTION

The application of fibre reinforced polymers as external reinforcement has received much attention from structural engineering. FRP laminates have gained popularity as external

* E-mail address of the corresponding author: jayajothi21civil@gmail.com (P. Jayajothi)

reinforcement for the strengthening or rehabilitation of reinforced concrete structures and they are preferred over steel plate due to their high tensile strength, high strength–weight ratio and corrosion resistance. Externally bonded FRP laminates and fabrics can be used to increase the shear as well as flexural strength of reinforced concrete beams and columns. It can be seen that the shear strength of columns can be easily improved by wrapping with a continuous sheet of FRP to form a complete ring around the member. Shear strengthening of beams, however, is likely to be more problematic when they are cast monolithically with slabs. Nevertheless, bonding FRP on either the side faces, or the side faces and soffit, will provide some shear strengthening for such members. FRP composites applied to the reinforced concrete members provide efficiency, reliability and cost effectiveness in rehabilitation.

Non-linear analysis of reinforced concrete beams strengthened with bonding steel or carbon-fibre reinforcement plates using ANSYS has been carried out by Ali [1]. Three-dimensional finite element analysis was conducted to obtain the response of the strengthened beams with steel and CFRP plates in terms of applied load-deflection, tension force distribution in the strengthening plates along the reinforced concrete beams, and bond force distribution in the beam with CFRP plate and beam with steel plate [1].

Analytical modelling has been presented by Amer M.Ibrahim and Mohammed Sh. Mahmood for reinforced concrete beams externally reinforced with fibre reinforced polymer (FRP) laminates using finite element method adopted by ANSYS. The accuracy of the finite element models is assessed by comparison with the experimental results, which are to be in good agreement. The load-deflection curves from the finite element analysis agree well with the experimental results [2].

Flexural behavior of reinforced and prestressed concrete beams has been studied by Anthony J. Wolanski using finite element analysis. This simulation work contains areas of study such as behavior at first cracking, behavior at initial cracking, behavior beyond first cracking, behavior of reinforcement yielding and beyond, strength limit state, load-deformation response of control beam and application of effective prestress, self-weight, zero deflection, decompression, initial cracking, secondary linear region, behavior of steel yielding and beyond, flexural limit state of prestressed concrete beam [3].

An experimental study on flexural behaviour of RC beams strengthened with Carbon Fibre Reinforced Polymer (CFRP) fabrics has been performed by Balamuralikrishnan and Antony Jeyasehar [4]. Eight beams were strengthened with bonded CFRP fabric in single layer and two layers which are parallel to beam axis at the bottom and tested until failure; the remaining two beams were used as control specimens. Static and cyclic responses of all the beams were evaluated in terms of strength, stiffness, ductility ratio, energy absorption capacity factor, compositeness between CFRP fabric and concrete, and the associated failure mode [4].

Damian Kachlakev and Thomas Miller have done finite element modeling of reinforced concrete structures strengthened with FRP Laminates with ANSYS and the objectives of this simulation was to examine the structural behavior of Horsetail Creek Bridge (This historic Bridge, built in 1914, is in use on the Historic Columbia River Highway east of Portland, Oregon, U.S.A), with and without FRP laminates; and establish a methodology for applying computer modeling to reinforced concrete beams and bridges strengthened with FRP

laminates [5].

Meisam Safari Gorji used finite element software ANSYS to predict the deflection of rectangular reinforced concrete beams strengthened by FRP composites applied at the bottom of the beams. To achieve the aim, potential energy model is formed and varied. The validity of the proposed model has been verified by comparing with the results of the finite element model. Results obtained from the energy variation method show very good agreement with results obtained from the finite element method [6].

This paper presents the numerical study to simulate the behaviour of control R.C beams and FRP strengthened reinforced concrete beams using ANSYS through nonlinear response and load up to failure. The results of load-deflection plots at midspan; loads at failure; and crack patterns at failure were compared. Comparison has been made also for the results of finite element analysis from ANSYS with the results of experimental studies available in literatures.

2. MODELLING & ANALYSIS

In this paper, four beams were modelled and analysed using ANSYS software. In four beams, two beams were control beams and two beams were FRP Strengthened beams. The control beam1 (CB1) and FRP beam1 (FRP1) is of size 1500 x 62.5 x 250 mm, then the control beam2 (CB2) and FRP beam2 (FRP2) is of size 1820 x 75 x 250 mm. Solid 45 element was used for CFRP in FRP beam1 and Solid 46 element was used for CFRP in FRP beam2.

2.1 Reinforced concrete

An eight-node solid element, Solid 65, was used to model the concrete. The solid element has eight nodes with three degrees of freedom at each node – translations in the nodal x, y, and z directions. The element is capable of plastic deformation, cracking in three orthogonal directions, and crushing. The geometry and node locations for this element type are shown in Figure 1.

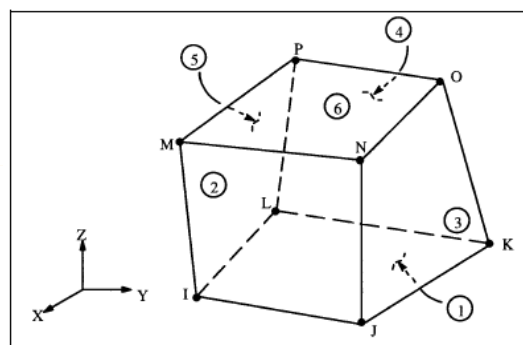

Figure 1. Solid 65- 3D reinforced concrete solid

2.2 Reinforcing Steel

A Link 8 element was used to model the steel reinforcement. Two nodes are required for this

element. Each node has three degrees of freedom, – translations in the nodal x , y , and z directions. The element is also capable of plastic deformation. The geometry and node locations for this element type are shown in Figure 2.

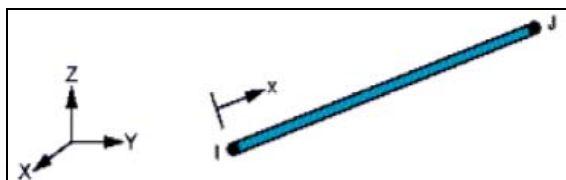

Figure 2. Link 8 element

2.3 FRP Composites

The Solid 45 and Solid 46 were the two elements that used to model the FRP composites. A layered solid element, Solid 46, was used to model the FRP composites. The element allows for up to 100 different material layers with different orientations and orthotropic material properties in each layer. The element has three degrees of freedom at each node and translations in the nodal x , y , and z directions.

An eight-node solid element, Solid 45, was used to model the FRP composites in the beam models. The element is defined with eight nodes having three degrees of freedom at each node – 8 translations in the nodal x , y , and z directions. The geometry and node locations for this element type are shown in Figure 3.

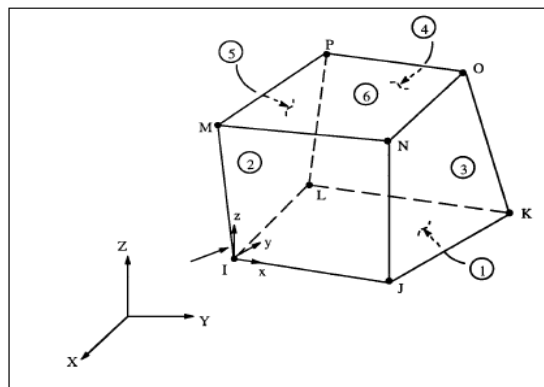

Figure 3. Solid 45- 3D solid

The analysis for the reinforced concrete beam included: non-linear concrete properties, bilinear steel properties, and the influence of progressive cracking of the concrete. The transverse loading was incrementally applied and ranged in magnitude from zero to a load well above that which initiated cracking. The finite element model produced very good results and that are compared well with experimental results. Due to the symmetry in cross-section of the concrete beam and loading, symmetry was utilized in the finite elements analysis; only one quarter of the beam was modeled. This approach reduced computational time and computer disk space requirements significantly. Also, concrete crack/crush plots were created at different load levels to examine the different types of cracking that occurred

within the concrete. The different types of concrete failure that can occur are flexural cracks, compression failure (crushing), and diagonal tension cracks.

3. NUMERICAL ANALYSIS

The experimental investigation of Balamuralikrishnan and Antony Jeyasehar [4] has been taken to simulate the model in ANSYS. The beams were modelled as volumes. The model is 3200 mm long, with a cross-section of 125mm x 250mm. Since a quarter of the beam is being modelled, the dimension of beam is 1500 mm x 62.5 mm x 250 mm and the beam without FRP is called as control beam1. The reinforcement at the bottom of beam is 2-12 mm dia and the reinforcement at top of beam is 2-10 mm dia, 6 mm dia stirrups @ 150 mm c/c as shown in Figure 4 [4]. The real constants for control beam 1 is given in Table 1.

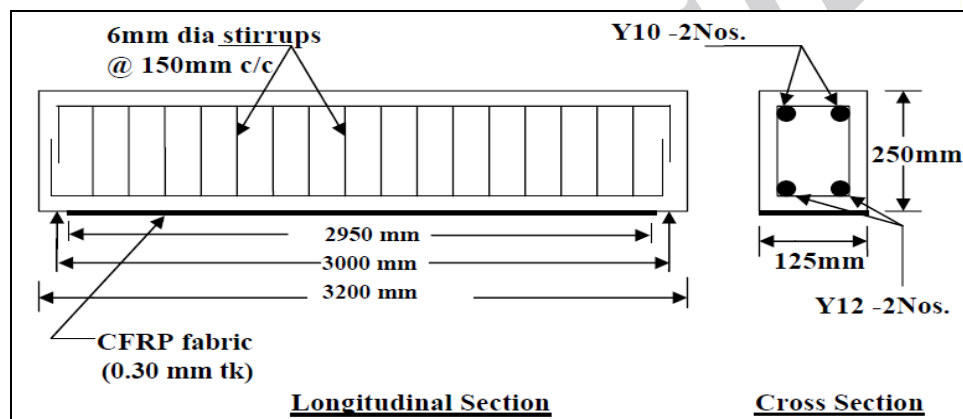

Figure 4. Longitudinal and cross section of beam1

Table 1: Real constants for control beam 1

Real constant set	Element type	Constants	Real constants		
			for rebar 1	for rebar 2	for rebar 3
1	Solid 65	Material number	0	0	0
		Volume ratio	0	0	0
		Orientation angle	0	0	0
		Orientation angle	0	0	0
2	Link 8	Cross sectional area(mm ²)	113.04		
3	Link 8	Cross sectional area(mm ²)	78.5		

4	Link 8	Cross sectional area (mm ²)	28.26
---	--------	---	-------

The experimental investigation of Ibrahim and Mahmood [2] has been taken to simulate the model in ANSYS. The control beam2 were modelled as volumes. The model is 3620 mm long, with a cross-section of 150 mm x 250 mm. Since a quarter of the beam is being modelled, the dimension of beam is 1820 mm x 75 mm x 250 mm and this is the control beam2. The reinforcement at the bottom of beam is 2-12 mm dia and the reinforcement at top of beam is 2-10 mm dia, 10mm dia stirrups @ 600 mm c/c as shown in Figure 5 [2]. The summary of inputs are given in Table 2 . In case of FRP beam U wrap is provided under the load which is near to the support.

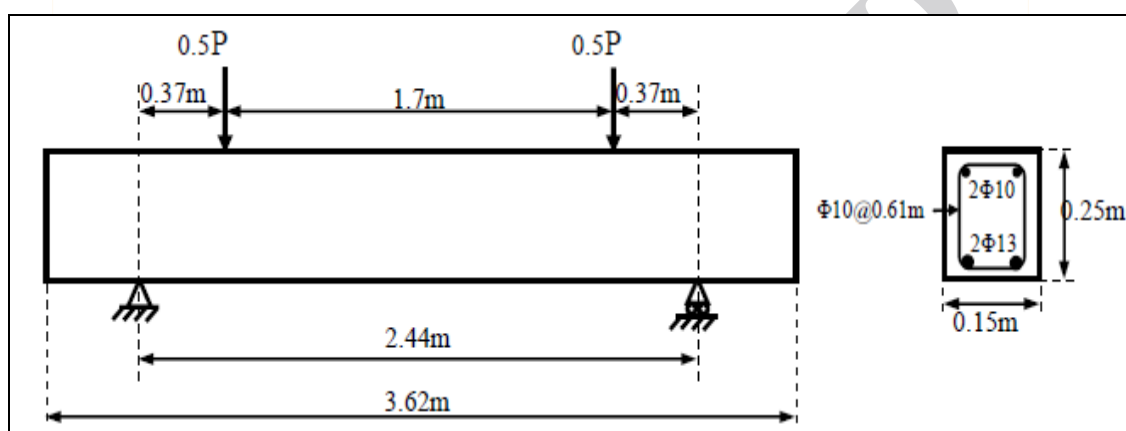

Figure 5. Longitudinal and cross section of beam2

Table 2: Summary of inputs

S.No	Materials	Material model	Element type	Real constants
1	Concrete	Linear isotropic Multilinear isotropic Concrete	Solid 65	Set 1
2	Steel	Linear isotropic Bilinear isotropic	Link 8	Set 2 Set 3

A finite element analysis requires meshing of the model. In other words, the model is divided into a number of small elements, and after loading, stress and strain are calculated at integration points of these small elements. This properly sets the width and length of elements in the plates to be consistent with the elements and nodes in the concrete portions of the model. The bond strength between the concrete and steel reinforcement should be considered. To provide the perfect bond, the link element for the steel reinforcing was connected between nodes of each adjacent concrete solid element, so the two materials shared the same nodes. The same approach was adopted for FRP composites. The numbering control command is used to merge all the items to make it as a single entity.

Meshing of FRP beam1 and FRP beam2 are shown in Figure 6 and Figure 7 respectively.

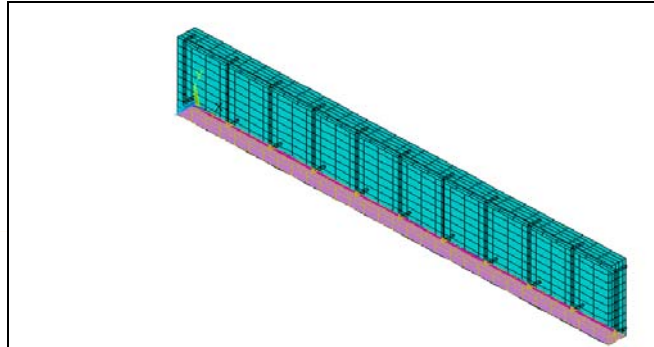

Figure 6. Meshing of concrete, reinforcement, CFRP plate

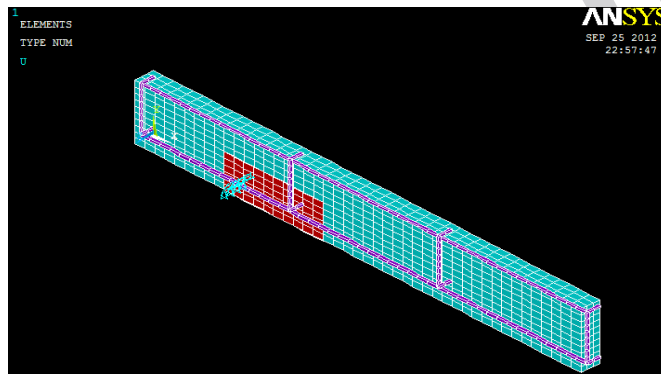

Figure 7. Meshing of concrete, reinforcement and CFRP layer

Nodes defining a vertical plane through the beam cross-section centroid define a plane of symmetry. To model the symmetry, nodes on this plane must be constrained in the perpendicular direction. These nodes, therefore have a degree of freedom constraint $UX = 0$. Second, all nodes selected at $Z = 0$ define another plane of symmetry. These nodes were given the constraint $UZ = 0$. A single line of nodes on the beams were given constraint in the UY , and UZ directions, applied as constant values of 0. The loads and boundary conditions of both FRP beam1 and FRP beam2 are shown in Figure 8 and Figure 9 respectively.

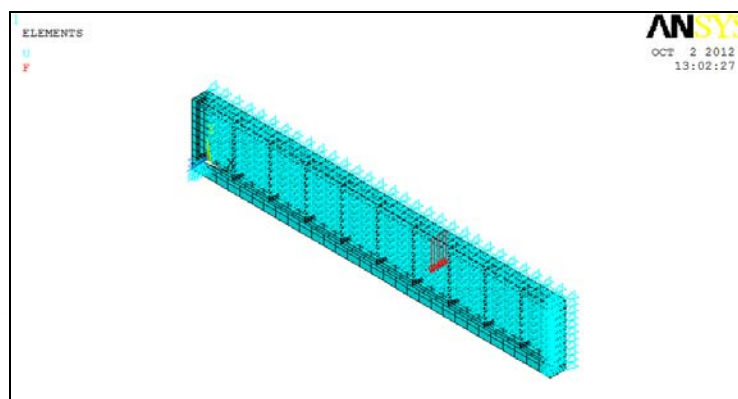

Figure 8. FRP beam1 with loads and boundary conditions

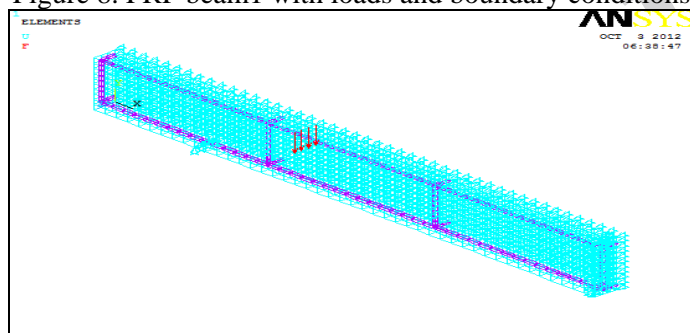

Figure 9. FRP Beam2 with loads and boundary conditions

The FE analysis of the model was set up to examine three different behaviours: initial cracking of the beam, yielding of the steel reinforcement, and the strength limit state of the beam. The Sol'n Controls command dictates the use of a linear or non-linear solution for the finite element model. Once the beam was analysed evolution of crack patterns can be obtained at the ultimate load.

The tolerance value of 0.1 is used for both force and displacement during the nonlinear solution for convergence. A small criterion must be used to capture correct response. This criteria was used for the remainder of the analysis. Flexural cracks were appeared between the loads exactly at mid span, diagonal tension cracks near supports and compressive cracks under the applied load. The Ultimate loads obtained are given in Table 3.

Table 3: Comparison of ultimate loads for model 1

S.No	Beam Id.	Ultimate loads in kN		Percentage increase in flexural capacity	
		Experimental	Numerical (ANSYS)	Experimental	Numerical (ANSYS)
1.	CB1	41.25	41.75	-	-
2.	FRP1	49.50	49.00	20	18

The experimental and numerical (ANSYS) ultimate loads are compared for both CB1 and FRP1. It reveals that percentage increase in flexural capacity has been increased up to 18%

for strengthened beam. The different components that were analyzed for comparison: the linear region, initial cracking, the nonlinear region, the yielding of steel, and failure.

Table 4: Comparison of ultimate loads for model 2

S.No	Beam Id.	Ultimate loads in kN		Percentage difference in ultimate load	Percentage increase in flexural capacity	
		Experimental	Numerical (ANSYS)		Experimental	Numerical (ANSYS)
1.	CB2	69	68	1.45	-	-
2.	FRP2	125	120	4	82	76

It is observed that 120 kN is the ultimate load for this FRP beam2 (FRP2) and the deflection is about 87.85 mm. The experimental and numerical (ANSYS) Ultimate Loads are compared for both CB2 and FRP2 and the values are given in Table 4. It reveals that percentage increase in flexural capacity has been increased up to 76% for strengthened beam.

4. RESULTS AND DISCUSSION

4.1 Load Deflection Curves

It clearly shows that up to the Point A graph is linear and it is called as linear region. In between the Points A to B it is Nonlinear which is named as nonlinear region and at the Point C it reaches its ultimate load. First cracking occurs at the Point A, Yielding of steel takes place at Point B and Failure at the Point C. Load-deflection curve for all the four beams are shown in Figure 10 to Figure 13.

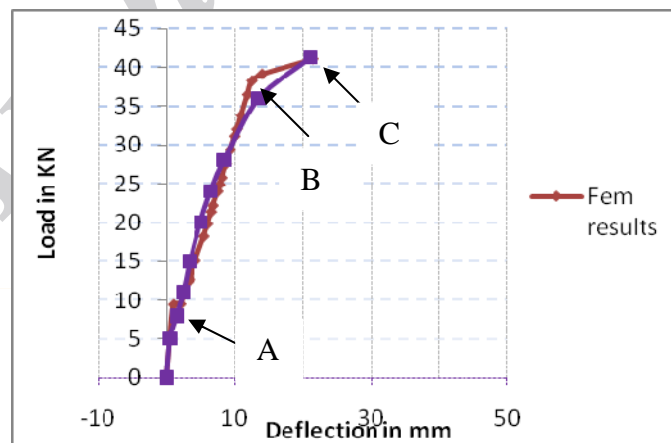

Figure 10. Load-deflection curve for control beam1

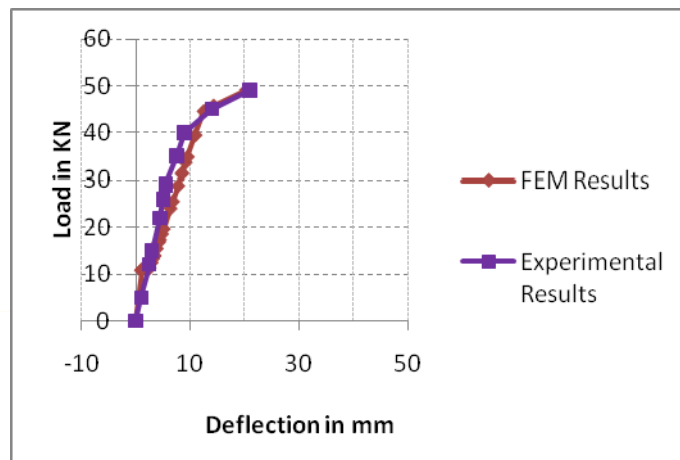

Figure 11. Load-deflection curve for FRP beam 1

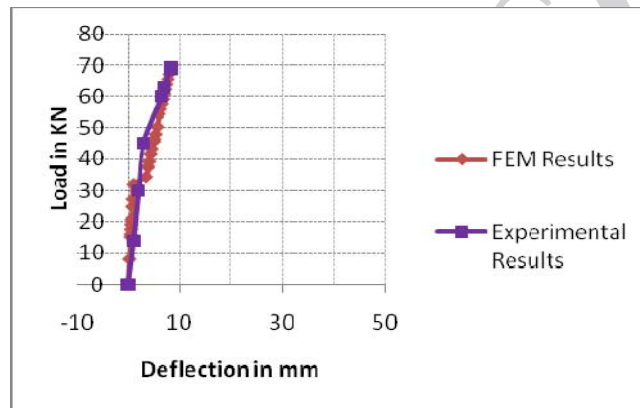

Figure 12. Load-deflection curve for control beam 2

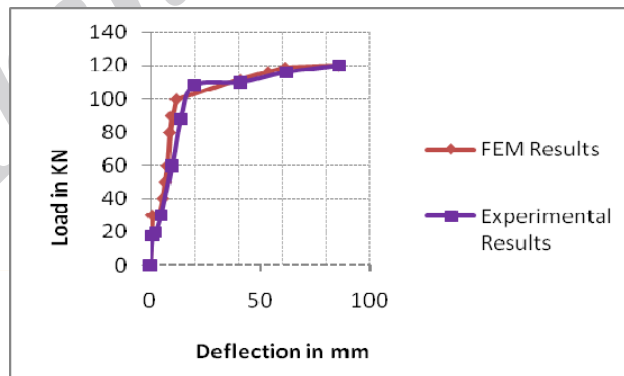

Figure 13. Load-deflection curve for FRP beam 2

4.2 Crack Patterns

The ANSYS program records a crack pattern at each applied load step. A cracking sign represented by a circle appears when a principal tensile stress exceeds the ultimate tensile

strength of the concrete. The cracking sign appears perpendicular to the direction of the principal stress. ANSYS program displays circles at locations of cracking or crushing in concrete elements. Cracking is shown with a circle outline in the plane of the crack, and crushing is shown with an octahedron outline. The first crack at an integration point is shown with a red circle outline, the second crack with a green outline, and the third crack with a blue outline.

The cracking pattern in the beam can be obtained using the Crack/Crushing plot option in ANSYS. Vector Mode plots must be turned on to view the cracking in the model. Flexural cracks form vertically up the beam. Compression failures are shown as circles under the load. Diagonal tension cracks form diagonally up the beam towards the loading that is applied. In general, flexural cracks occur early at midspan. When applied loads increase, vertical flexural cracks spread horizontally from the midspan to the support. At a higher applied load, diagonal tensile cracks appear. Increasing applied loads induces additional diagonal and flexural cracks. Finally, compressive cracks appear at nearly the last applied load steps. The crack patterns of all the beams are shown in Figure 14 to Figure 17. The ultimate loads and deflection at mid span obtained in Numerical (ANSYS) are compared with Experimental results for all the beams. The values are given in Table 5.

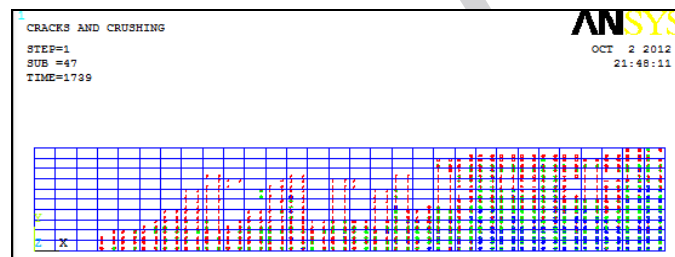

Figure 14. Integration of all cracks at 41kN for CB1

Diagonal tension cracks Flexural cracks Compressive Cracks

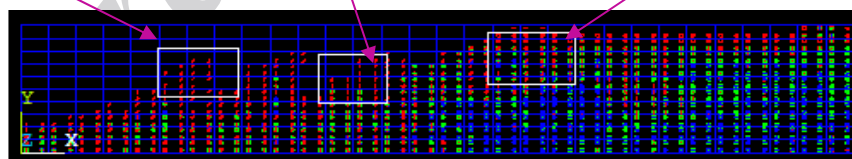

Figure 15. Integration of all cracks at 49.00kN for FRP Beam 1

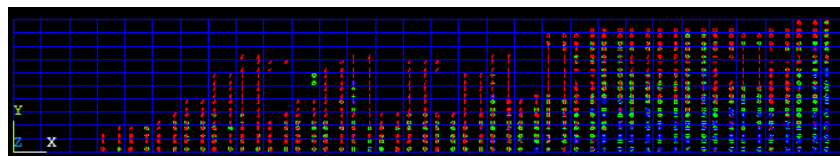

Figure 16. Integration of cracks at ultimate load 68kN for CB2

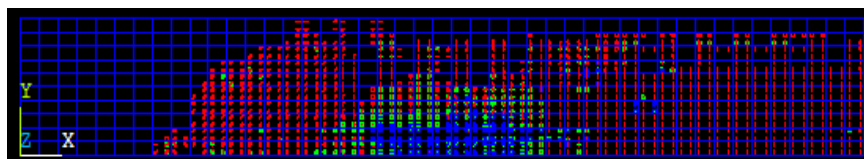

Figure 17. Integration of all cracks at 120kN for FRP beam2

Table 5: Comparison of Experimental & Numerical results

Beam Id.	Ultimate load kN		Deflection at mid span,mm	
	Experimental	Numerical (ANSYS)	Experimental	Numerical (ANSYS)
CB1	41.25	41.00	21.13	21.75
CB2	69	68	8.35	8.263
FRP1	49.5	49	20.13	20.83
FRP2	125	120	86.25	87.85

4. CONCLUSIONS

Based on the results obtained from theoretical analyses, the following conclusions are drawn:

- The ultimate load carrying capacity of all the strengthened beams is higher when compared to the control beams.
- CFRP fabric properly bonded to the tension face of RC beams can enhance the flexural strength substantially. The strengthened beam FRP1 exhibit an increase in flexural strength of 18 to 20 percent for single layer.
- The load carrying capacity of the strengthened beam FRP2 which was strengthened using a single layer U-wrap CFRP was found to be higher when compared to FRP1 beam which was strengthened using a CFRP plate at the tension face of beam.
- The load carrying capacity of the strengthened beam FRP2 which was strengthened using a single layer U-wrap CFRP was found to be higher when compared to control beam2. The strengthened beam FRP2 exhibit an increase in flexural strength of 76 to 82 percent for single layer.
- The numerical solution was adopted to evaluate the ultimate strength of the reinforced concrete beams reinforced with FRP laminates in simple, cheap and rapid way compared with experimental full scale test.
- The general behaviors of the finite element models show good agreement with observations and data from the experimental full-scale beam tests. Therefore, the simulation of FRP beams can be done using ANSYS.

REFERENCES

1. Ali L Abbas. Non-linear analysis of reinforced concrete beams strengthened with steel and CFRP plates, *Diyala Journal of Engineering Sciences*, Special Issue, December

- (2010) 249-56.
2. Ibrahim AM, Mahmood MS. Finite element modeling of reinforced concrete beams strengthened with FRP laminates, *European Journal of Scientific Research*, No. 4, **30** (2009)526-41.
 3. Anthony J Wolanski. *Flexural Behavior of Reinforced and Prestressed Beams Using Finite Element Analysis*, MS Thesis, Marquette University, 2004.
 4. Balamuralikrishnan R, Antony Jeyasehar C. Flexural Behavior of RC Beams Strengthened with Carbon Fiber Reinforced Polymer (CFRP) Fabrics, *The Open Civil Engineering Journal*, **3**(2009) 102-9.
 5. Damian Kachlakev, Thomas Miller. *Finite element modeling of reinforced concrete structures strengthened with FRP laminates*, Research Report, SPR 316, Oregon Department of Transportation Research Group, 2001.
 6. Safari Gorji M. Analysis of FRP Strengthened Reinforced Concrete Beams Using Energy Variation Method, *World Applied Sciences Journal*, **6**(2009)105-11.

Archive of SID