

# Wave Propagation at the Boundary Surface of Inviscid Fluid Half-Space and Thermoelastic Diffusion Solid Half-Space with Dual-Phase-Lag Models

R. Kumar<sup>1</sup>, V. Gupta<sup>2,\*</sup>

<sup>1</sup>Department of Mathematics, Kurukshetra University Kurukshetra-136119, Haryana, India

<sup>2</sup>Indira Gandhi National College, Ladwa(Dhanora), Haryana, India

Received 20 June 2015; accepted 17 August 2015

## ABSTRACT

The present investigation deals with the reflection and transmission phenomenon due to incident plane longitudinal wave at a plane interface between inviscid fluid half-space and a thermoelastic diffusion solid half-space with dual-phase-lag heat transfer (DPLT) and dual-phase-lag diffusion (DPLD) models. The theory of thermoelasticity with dual-phase-lag heat transfer developed by Roychoudhary [10] has been employed to develop the equation for thermoelastic diffusion with dual-phase-lag heat transfer and dual-phase-lag diffusion model. Amplitude ratios and energy ratios of various reflected and transmitted waves are obtained. It is found that these are the functions of angle of incidence, frequency of incident wave and are influenced by thermoelastic diffusion properties of media. The nature of dependence of amplitude ratios and energy ratios with the angle of incidence have been computed numerically for a particular model. The variations of energy ratios with angle of incidence are also shown graphically. The conservation of energy at the interface is verified. Some special cases are also deduced from the present investigation.

© 2015 IAU, Arak Branch. All rights reserved.

**Keywords** : Thermoelasticity; Fluid; Elastic; Reflection; Transmission; Amplitude; Energy.

## 1 INTRODUCTION

B IOT [1] formulated the coupled thermoelasticity theory to eliminate the paradox inherent in the classical uncoupled theory that elastic deformation has no effect on the temperature.

The generalized theories of thermoelasticity have been developed in order to remove the paradox of physical impossible phenomena of infinite velocity of thermal signals in the classical coupled thermoelasticity. Hetnarski and Ignaczak [2] examined five theories of the coupled theory of thermoelasticity.

Lord and Shulman [3] formulated the thermoelasticity theory involving one thermal relaxation time. This theory is referred to as LS theory or extended thermoelasticity theory (ETE) in which the Maxwell-Cattaneo law replaces the Fourier law of heat conduction by introducing a single parameter that acts as a relaxation time.

Green and Lindsay [4], developed a temperature rate-dependent thermoelasticity that includes two thermal relaxation times. This theory is called as the GL theory or temperature rate dependent theory (TRDTE).

\* Corresponding author.

E-mail address: vandana223394@gmail.com (V.Gupta).

The third coupled theory of thermoelasticity was developed by Hetnarski and Ignaczak [5] and was known as low temperature thermoelasticity. The fourth coupled theory of thermoelasticity was introduced by Green and Nagdhi [6]. They posulated a new concept of thermoelasticity which is called the thermoelasticity without energy dissipation. In this theory, the classical Fourier law is replaced by a heat flux rate-temperature gradient relation. The general idea is posulated by Green and Nagdhi [7] in making use of the general entropy balance. Three types of the constitutive response functions are suggested. Type I, after linearization of the theory, is the same as the classical heat conduction theory (based on Fourier's law), while the types II and III permit propagation of thermoelastic disturbances with a finite speed, only type II without energy dissipation. Also GN model III of thermoelasticity theory involves a heat conduction law and one that involves the thermal displacement gradient among the constitutive variables. One can refer to Hetnarski and Ignaczak [5] for a review and presentation of generalized theories of thermoelasticity.

The fifth coupled theory of thermoelasticity is developed by Tzou [8] and Chandrasekhariah [9] and is referred to dual phase-lag thermoelasticity. Tzou [8] proposed a generalized heat conduction law, referred as heat conduction law with dual-phase-lags, in which microstructural effects in the heat transfer mechanism have been considered in the macroscopic formulation by taking into account that photon-electron interactions on the macroscopic level causes a delay in the increase of the lattice temperature. A corresponding thermoelastic model with two phase lag was reported by Chandrasekhariah [9]. In the models [8, 9] two different phase lags i.e., one for the heat flux vector and other for the temperature gradient have been introduced in the Fourier's law. The phase-lag of heat flux vector is interpreted as the relaxation time due to fast transient effects of thermal inertia and the phase-lag of temperature gradient is interpreted as the delay time caused due to the microstructural interactions, a small scale effect of heat transport in space, such as photon-electron interaction or photon scattering. Roychoudhary [10] formulated a three-phase-lag model of the linearized theory of coupled thermoelasticity by considering the heat conduction law that includes temperature gradient and the thermal displacement gradient among the constitutive variables.

Sinha and Elsibai [11] discussed the reflection and refraction of thermoelastic waves at an interface of two semi-infinite media with two relaxation times. Kumar and Sharma [12] obtained the amplitude ratios from the stress free boundary in a micropolar thermoelastic half space without energy dissipation. Kumar and Sarthi [13] discussed the reflection and transmission of thermoelastic plane waves at an interface of thermoelastic media without energy dissipation. Kumar and Singh [14] studied the propagation of plane waves in thermoelastic cubic material. Kumar and Kansal [15] discussed the reflection of plane waves of a transversely isotropic thermoelastic diffusive half-space. Kumar and Kansal [16] discussed the reflection of plane waves of an elastic and thermoelastic solid half-space with diffusion.

Podstrigach [17] considered the problem of thermodiffusion in classical elastic material and investigated the fundamental corollaries and differential equations. Podstrigach and Pavlina [18] constructed the differential equations of thermodynamic processes in an n-component solid solution. Podstrigach [19] presented the diffusion theory of strain of an isotropic solid medium. Podstrigach [20] examined the diffusion theory of inelasticity of metals. Podstrigach and Pavlina [21, 22] investigated diffusion processes in a viscoelastic deformable body and layer respectively. Podstrigach, Shavets and Pavlina [23] studied a quasi-stationary coupled spatial and plane problems of thermodiffusion and the physic-mechanical state of a circular cylinder under the action of cyclic forces. Nowacki [24, 25, 26, 27] developed the theory of thermoelastic diffusion by using coupled thermoelastic model. Dudziak and Kowalski [28] and Olesiak and Pyryev [29], respectively, discussed the theory of thermodiffusion and coupled quasi-stationary problems of thermal diffusion for an elastic layer. They studied the influence of cross effects arising from the coupling of the fields of temperature, mass diffusion and strain due to which the thermal excitation results in additional mass concentration and that generates additional fields of temperature. Gawinecki and Szymaniec [30] proved a theorem about global existence of the solution for a non-linear parabolic thermoelastic diffusion problem. Wu and Zhu [31] studied the propagation of Lamb waves in a plate bordered with inviscid liquid layer on both sides. Propagation of Rayleigh surface waves in microstretch thermoelastic continua under inviscid fluid loading have been investigated by Sharma et al. [32]. The propagation of free vibrations in microstretch thermoelastic homogeneous, isotropic, thermally conducting plate bordered with layers of inviscid liquid on both sides subjected to stress free thermally insulated and isothermal conditions have been investigated by Kumar and Pratap [33]. Reflection and transmission at the interface of solid and fluid half-spaces in a general anisotropic poroelastic medium was studied by Sharma [34].

In the present paper, the reflection and refraction at a plane interface between an inviscid fluid half-space and a thermoelastic diffusion solid half-space has been analyzed. Dual-phase-lag heat transfer (DPLT) and Dual-phase-lag diffusion (DPLD) models are considered in the thermoelastic diffusion medium. Also in this medium potential functions are introduced to represent three longitudinal waves and one transverse wave. The amplitude ratios of various reflected and refracted waves to that of incident wave are derived. The amplitude ratios are further used to

find the expressions of energy ratios of various reflected and refracted waves to that of incident wave. The graphical representation is given for these energy ratios for different direction of propagation. The law of conservation of energy at the interface is verified.

## 2 DUAL-PHASE-LAG DIFFUSION MODEL

Analogous to Fourier's law of heat conduction, the Fick's law for mass flux is of the form [Sherief et al. [35]]

$$\eta_i = -DP_{,i}, \quad (1)$$

The mass concentration law is

$$-\eta_{i,i} = \dot{C}, \quad (2)$$

where  $D$  is the diffusivity,  $P$  is the chemical potential per unit mass,  $C$  is the concentration and  $\eta_i$  is the flow of diffusing mass vector.

Introducing phase-lag of diffusing mass vector  $\eta$  and chemical potential  $P$  in Eq. (1), we arrive at

$$\eta_i(R, t + \tau_\eta) = -DP_{,i}(R, t + \tau_p), \quad (3)$$

The potential gradient at a point  $R(r)$  at time  $t + \tau_p$  results in a mass flux at the same point at time  $t + \tau_\eta$ . The phase-lag of diffusing mass flux vector  $\tau_\eta$ , represents the delayed time required for the diffusion of the mass flux and the phase-lag of chemical potential  $\tau_p$ , represents the delayed time required for the establishment of the potential gradient. Eq. (3) indicates that for the case of  $\tau_\eta > \tau_p$  the potential gradient established across a material volume located at the point  $R$  at time  $t + \tau_p$  results in a mass flux to diffuse at a different instant of time  $t + \tau_\eta$ . In the cases where  $\tau_\eta > \tau_p$ , a mass flux diffused in a material volume at  $t + \tau_\eta$  would estimate a potential gradient at  $t + \tau_p$ . Like the property  $D$ , the two lag times should depend upon environmental temperature as well as other process conditions and are treated as intrinsic properties characterizing the transient process of mass transport. For the special case of  $\tau_\eta = \tau_p = \tau$  (though not necessarily equal to zero), Eq. (3) simplifies to Fick's law. This implies that an instantaneous response between the mass flux vector and the chemical potential is the assumption behind the classical Fick's diffusion theory. The other special condition of  $\tau_p = 0$  and  $\tau_\eta \neq 0$  leads to a wave model with a mass transport speed of  $(D/\tau_\eta)^{1/2}$  and a diffusion damping effect.

The Taylor series expansion of (3) upto the first order terms in  $\tau_\eta, \tau_p$  leads to the following generalized Fick's law valid at point  $R$  and time  $t$  as:

$$\eta_i(1 + \tau_\eta(\partial/\partial t)) = -DP_{,i}(1 + \tau_p(\partial/\partial t)), \quad (4)$$

By taking the gradient of both sides of (4) and using Eq. (2), we arrive at

$$(1 + \tau_\eta(\partial/\partial t))\dot{C} = D(1 + \tau_p(\partial/\partial t))P_{,ii}, \quad (5)$$

The relation between chemical potential  $P$  and mass concentration  $C$  is

$$P = -\beta_2 e_{kk} - aT + bC, \quad (6)$$

Using Eq. (6) in (5), we arrive at the mass diffusion equation in this case, namely

$$(1 + \tau_p (\partial / \partial t)) (D\beta_2 e_{kk,ii} + DaT_{,ii} - DbC_{,ii}) + (\partial / \partial t) (1 + \tau_\eta (\partial / \partial t)) C = 0, \quad (7)$$

### 2.1 Hyperbolic dual-phase-lag diffusion model

Retaining terms of the order  $\tau_\eta^2$  in the Taylor's expansion of the generalized diffusion law (7), we have

$$(1 + \tau_p (\partial / \partial t)) (D\beta_2 e_{kk,ii} + DaT_{,ii} - DbC_{,ii}) + (\partial / \partial t) (1 + \tau_\eta (\partial / \partial t) + (\tau_\eta^2 / 2) (\partial / \partial t)^2) C = 0, \quad (8)$$

## 3 GOVERNING EQUATIONS

Following Roy Choudhuri [10], Kumar and Kansal [16], the basic equations in a homogeneous isotropic generalized thermoelastic diffusion medium with DPLT and DPLD models in the absence of body forces, heat sources and mass diffusion sources are

The constitutive relations

$$\sigma_{ij} = 2\mu e_{ij} + \delta_{ij} [\lambda e_{kk} - \beta_1 T - \beta_2 C], \quad (9)$$

$$\rho T_0 S = \rho C_E T + \beta_1 T_0 e_{kk} + a T_0 C, \quad (10)$$

The equations of motion

$$(\lambda + \mu) u_{j,ij} + \mu u_{i,jj} - \beta_1 T_{,i} - \beta_2 C_{,i} = \rho \ddot{u}_i, \quad (11)$$

The heat conduction equations

$$(1 + \tau_t (\partial / \partial t)) K T_{,ii} = (1 + \tau_q (\partial / \partial t) + (\tau_q^2 / 2) (\partial / \partial t)^2) [\rho C_E \dot{T} + \beta_1 T_0 \dot{e}_{kk} + a T_0 \dot{C}], \quad (12)$$

Eqs. (9)-(12) together with Eq. (8) constitutes the basic equations for homogeneous isotropic generalized thermoelastic diffusion with DPLT and DPLD models.

where  $\lambda, \mu$  are the Lamé's constants,  $\rho$  is the density assumed to be independent of time,  $u_i$  are the components of displacement vector  $u$ ,  $K$  is the coefficient of thermal conductivity,  $C_E$  is the specific heat at constant strain,  $\tau_t, \tau_q$  are the phase-lag of the temperature gradient and heat flux respectively,  $T = \Theta - T_0$  is small temperature increment,  $\Theta$  is the absolute temperature of the medium;  $T_0$  is the reference temperature of the body chose such that  $|(T / T_0)| \ll 1$ ,  $a$  and  $b$  are respectively, the coefficients describing the measure of thermodiffusion and mass diffusion effects respectively,  $\sigma_{ij}, e_{ij}$  are the components of the stress and strain respectively,  $e_{kk}$  is the dilatation,  $S$  is the entropy per unit mass,  $\beta_1 = (3\lambda + 2\mu)\alpha_t$  and  $\beta_2 = (3\lambda + 2\mu)\alpha_c$ ,  $\alpha_t$  is the coefficient of thermal linear expansion,  $\alpha_c$  is the coefficient of linear diffusion expansion. In the above equations, a comma followed by a suffix denotes spatial derivative and a superposed dot denotes the derivative with respect to time.

## 4 FORMULATION OF THE PROBLEM

We consider an inviscid fluid half-space lying over a homogeneous isotropic, generalized thermoelastic diffusion solid half-space with dual-phase-lag models (DPLT and DPLD). The origin of the Cartesian coordinate system  $(x_1, x_2, x_3)$  is taken at any point on the plane surface (interface) and  $x_3$ -axis points vertically downwards into the

thermoelastic diffusion solid half-space. The fluid half-space occupies the region  $x_3 \leq 0$  (Medium I) and the region  $x_3 \geq 0$  is occupied by the dissipative thermoelastic diffusion solid half-space (Medium II) with dual-phase-lag models (DPLT and DPLD) as shown in Fig.1. We consider plane waves in  $x_1 - x_3$  plane with wavefront parallel to the  $x_2$ -axis.

For two dimensional problem, the displacement vector  $u$  in Medium II is taken as:

$$u = (u_1, 0, u_3) \quad (13)$$

We define the dimensionless quantities

$$\begin{aligned} x'_1 &= (\omega_1^* x_1 / c_1), x'_3 = (\omega_1^* x_3 / c_1), u'_1 = (\omega_1^* u_1 / c_1), u'_3 = (\omega_1^* u_3 / c_1), \\ u'^{f'}_1 &= (u^f_1 / c_1), u'^{f'}_3 = (u^f_3 / c_1), t' = \omega_1^* t, T' = (\beta_1 T / \rho c_1^2), C' = (\beta_2 C / \rho c_1^2), \\ \tau'_q &= \omega_1^* \tau_q, \tau'_t = \omega_1^* \tau_t, \tau'_p = \omega_1^* \tau_p, \tau'_\eta = \omega_1^* \tau_\eta, \phi^{f'} = (\omega_1^* \phi^f / c_1^2), p^{f'} = (p^f / \beta_1 T_0), \\ \sigma^{f'}_{ij} &= (\sigma^f_{ij} / \beta_1 T_0), \sigma'_{ij} = (\sigma_{ij} / \beta_1 T_0), P^{*f'} = (P^{*f} / \beta_1 T_0 c_1), P_{ij}^{*'} = (P_{ij}^* / \beta_1 T_0 c_1), \\ \omega_1^* &= (\rho C_E c_1^2 / K), c_1^2 = ((\lambda + 2\mu) / \rho). \end{aligned} \quad (14)$$

The displacement components  $u_1$  and  $u_3$  are related to the potential functions  $\phi$  and  $\psi$  as:

$$u_1 = (\partial\phi / \partial x_1) - (\partial\psi / \partial x_3), u_3 = (\partial\phi / \partial x_3) + (\partial\psi / \partial x_1), \quad (15)$$

Eqs. (8), (11) and (12) with the aid of (13)-(15), after suppressing the primes yield

$$\nabla^2 \phi - T - C = \ddot{\phi}, \quad (16)$$

$$\nabla^2 \psi - (\ddot{\psi} / \delta^2) = 0, \quad (17)$$

$$\tau_t^1 \nabla^2 T = \tau_q^1 (\dot{T} + \zeta_1 \nabla^2 \dot{\phi} + \zeta_2 \dot{C}), \quad (18)$$

$$\tau_p^1 (q_1^* \nabla^4 \phi + q_2^* \nabla^2 T + q_3^* \nabla^2 C) + \tau_\eta^1 q_4^* \dot{C} = 0, \quad (19)$$

where

$$\begin{aligned} c_2 &= \sqrt{(\mu / \rho)}, \delta^2 = (c_2^2 / c_1^2), \zeta_1 = (\beta_1^2 T_0 / K \rho \omega_1^*), \zeta_2 = (a T_0 c_1^2 \beta_1 / K \omega_1^* \beta_2), \\ q_1^* &= D \beta_2, q_2^* = (D a \rho c_1^2 / \beta_1), q_3^* = (D b \rho c_1^2 / \beta_2), q_4^* = (\rho c_1^4 / \omega_1^* \beta_2), \\ \tau_t^1 &= 1 + \tau_t (\partial / \partial t), \tau_q^1 = 1 + \tau_q (\partial / \partial t) + (\tau_q^2 / 2) (\partial^2 / \partial t^2), \\ \tau_p^1 &= 1 + \tau_p (\partial / \partial t), \tau_\eta^1 = 1 + \tau_\eta (\partial / \partial t) + (\tau_\eta^2 / 2) (\partial^2 / \partial t^2), \\ e_{kk} &= (\partial u_1 / \partial x_1) + (\partial u_3 / \partial x_3), \nabla^2 \equiv (\partial^2 / \partial x_1^2) + (\partial^2 / \partial x_3^2). \end{aligned}$$

For the propagation of Harmonic waves in  $x_1, x_3$  - plane, we assume

$$\{\phi, \psi, T, C\}(x_1, x_3, t) = \{\bar{\phi}, \bar{\psi}, \bar{T}, \bar{C}\} e^{-i\omega t}, \quad (20)$$

where  $\omega$  is the angular frequency of vibrations of material particles.

Eqs. (16)-(19) with the aid of (20), after simplification, we obtain

$$[G_1 \nabla^6 + G_2 \nabla^4 + G_3 \nabla^2 + G_4] \bar{\phi} = 0, \tag{21}$$

$$[\nabla^2 + (\omega^2 / \delta^2)] \bar{\psi} = 0, \tag{22}$$

where

$$G_1 = IH + JEI, G_2 = GI + HB + \omega^2 IH + AH + J(EB - AF - E - F),$$

$$G_3 = BG + \omega^2 (GI + HB - JF) + AH, G_4 = \omega^2 BG, A = -i\omega \tau_i^{11} \zeta_1,$$

$$B = -i\omega \tau_q^{11}, I = -i\tau_i^{11}, J = -i\omega \tau_q^{11} \zeta_2, E = q_1^* \tau_p^{11}, F = q_2^* \tau_p^{11},$$

$$G = -i\omega \tau_\eta^{11} q_4^*, H = -q_3^* \tau_p^{11}.$$

$$\tau_i^{11} = (1 - i\omega \tau_i), \tau_q^{11} = (1 - i\omega \tau_i + (-i\omega)^2 (\tau_q^2 / 2)),$$

$$\tau_p^{11} = (1 - i\omega \tau_p), \tau_\eta^{11} = (1 - i\omega \tau_\eta + (-i\omega)^2 (\tau_\eta^2 / 2)).$$

The general solution of Eq. (21) can be written as:

$$\bar{\phi} = \bar{\phi}_1 + \bar{\phi}_2 + \bar{\phi}_3, \tag{23}$$

where the potentials  $\bar{\phi}_i, i=1,2,3$  are solutions of wave equations, given by

$$[\nabla^2 + (\omega^2 / V_i^2)] \bar{\phi}_i = 0, i = 1,2,3. \tag{24}$$

Here  $V_1, V_2, V_3$  are the velocities of three longitudinal waves, that is,  $P$ , MD (Mass Diffusive) and  $T$  (Thermal) waves and derived from the roots of cubic equations in  $V^2$ , given by

$$G_4 V^6 - G_3 \omega^2 V^4 + G_2 \omega^4 V^2 - G_1 \omega^6 = 0. \tag{25}$$

From Eq. (22), we obtain

$$[\nabla^2 + (\omega^2 / V_4^2)] \bar{\psi} = 0, \tag{26}$$

where  $V_4 = \delta$  is the velocity of transverse waves.

Making use of Eq. (23) in the Eqs. (18) and (19) with the aid of Eqs. (20) and (24), we obtain

$$\{\phi, T, C\} = \sum_{i=1}^3 \{1, n_i, k_i\} \phi_i, \tag{27}$$

where  $n_i, k_i, (i=1,2,3)$  are given in Appendix A.

Following Achenbach [36], the field equations can be expressed in terms of velocity potential for inviscid fluid as:

$$p^f = -\rho^f \dot{\phi}^f \tag{28}$$

$$\left( \nabla^2 - \frac{1}{\alpha_p^2} \frac{\partial^2}{\partial t^2} \right) \phi^f = 0 \tag{29}$$

$$\mathbf{u}^f = \nabla\phi^f, \quad (30)$$

For two dimensional problem,  $\mathbf{u}^f = (u_1^f, 0, u_3^f)$  can be written in terms of velocity potential as:

$$u_1^f = (\partial\phi^f / \partial x_1), u_3^f = (\partial\phi^f / \partial x_3), \quad (31)$$

Applying the dimensionless quantities (14) in Eqs. (28) and (29) and after suppressing the primes, we obtain

$$p^f = -\zeta\dot{\phi}^f \quad (32)$$

$$\left( \nabla^2 - \frac{1}{v_p^{f^2}} \frac{\partial^2}{\partial t^2} \right) \phi^f = 0 \quad (33)$$

where  $\zeta = \rho^f c_1^2 / \beta_1 T_0$ ,  $v_p^f = \alpha_p^f / c_1$ ,  $\alpha_p^{f^2} = \lambda^f / \rho^f$  and  $\lambda^f$  is the bulk modulus,  $\rho^f$  is the density of the liquid,  $\mathbf{u}^f$  is the velocity vector and  $p^f$  is the acoustic pressure of the inviscid fluid.

## 5 REFLECTION AND TRANSMISSION

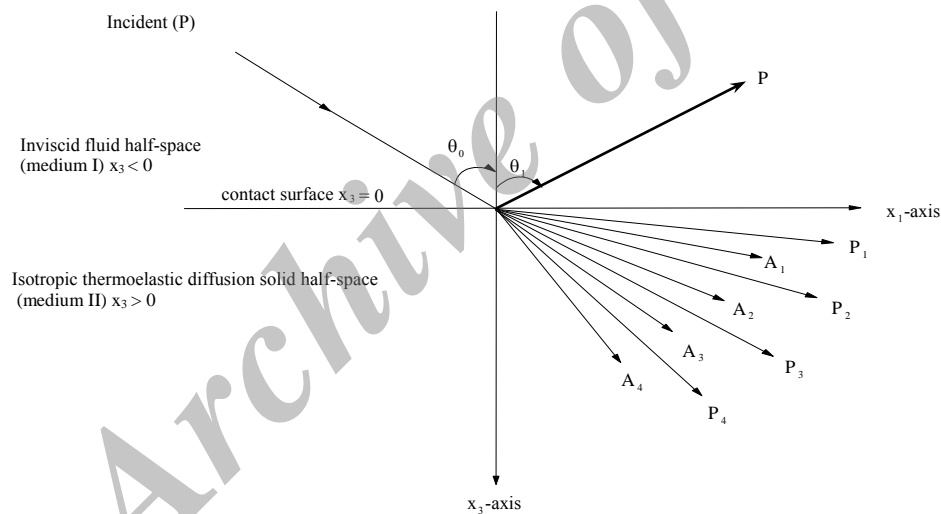

**Fig.1**  
Geometry of the problem.

We consider a plane harmonic wave (P) propagating through the inviscid fluid half-space and is incident at the interface  $x_3 = 0$ . Corresponding to incident wave, one homogeneous wave (P) is reflected in inviscid fluid half-space and four inhomogeneous waves (P, T, MD and SV) are refracted in isotropic thermoelastic diffusion solid half-space with DPLT and DPLD models.

In inviscid fluid half-space, the potential functions satisfying Eq. (33) can be written as:

$$\phi^f = A_0^f \exp[i\omega\{(x_1 \sin\theta_0 + x_3 \cos\theta_0)/v_p^f\} - t] + A_1^f \exp[i\omega\{(x_1 \sin\theta_1 - x_3 \cos\theta_1)/v_p^f\} - t], \quad (34)$$

The coefficients  $A_0^f$  and  $A_1^f$  are amplitudes of the incident P and reflected P waves, respectively.

Following Borchardt [37], the potential functions in isotropic thermoelastic diffusion half-space with DPLT and DPLD models, satisfying Eqs. (24) and (26) can be written as:

$$\{\phi, T, C\} = \sum_{i=1}^3 \{1, n_i, k_i\} B_i \exp(A_i \cdot r) \exp\{i(P_i \cdot r - \omega t)\}, \tag{35}$$

$$\psi = B_4 \exp(A_3 \cdot r) \exp\{i(P_3 \cdot r - \omega t)\}. \tag{36}$$

The coefficients  $B_i, i = 1, 2, 3, 4$  are the amplitudes of refracted P, T, MD and SV waves, respectively. The propagation vector  $P_i, i = 1, 2, 3, 4$  and attenuation factor  $A_i, i = 1, 2, 3, 4$  are given by

$$P_i = \xi_R \hat{x}_1 + dV_{iR} \hat{x}_3, A_i = -\xi_I \hat{x}_1 - dV_{iI} \hat{x}_3, i = 1, 2, 3, 4. \tag{37}$$

where

$$dV_i = dV_{iR} + idV_{iI} = p.v.((\omega^2 / V_i^2) - \xi^2), i = 1, 2, 3, 4. \tag{38}$$

And  $\xi = \xi_R + i\xi_I$  is the complex wave number. The subscripts  $R$  and  $I$  denote the real and imaginary parts of the corresponding complex number and p.v. stands for the principal value of the complex quantity derived from square root.  $\xi_R \geq 0$  ensures propagation in positive  $x_1$ -direction. The complex wave number  $\xi$  in the isotropic thermoelastic medium with DPLT and DPLD models is given by

$$\xi = |P_i| \sin \theta'_i - i|A_i| \sin(\theta'_i - \gamma_i), i = 1, 2, 3. \tag{39}$$

where  $\gamma_i, i = 1, 2, 3, 4$  is the angle between the propagation and attenuation vector and  $\theta'_i, i = 1, 2, 3, 4$  is the angle of transmission in Medium II.

## 6 BOUNDARY CONDITIONS

The boundary conditions considered are the continuity of stress and displacement components with insulated and impermeable boundary at the interface  $x_3 = 0$

Mathematically these can be written as:

$$\sigma_{33} = -p^f, \sigma_{31} = 0, u_3 = u_3^f, \partial T / \partial x_3 = 0, \partial C / \partial x_3 = 0, \tag{40}$$

Making use of potentials given by Eqs. (34)-(36), we find that the boundary conditions are satisfied if and only if

$$\xi_R = \omega \sin \theta_0 / v_p^f = \omega \sin \theta_1 / v_p^f, \tag{41}$$

and  $\xi_I = 0$

It means that waves are attenuating only in  $x_3$ -direction. From Eq. (39), it implies that if  $|A_i| \neq 0$ , then  $\gamma_i = \theta'_i, i = 1, 2, 3$ , that is, attenuated vectors for the four refracted waves are directed along the  $x_3$ -axis.

Using Eqs. (34)-(36) in the boundary conditions with the aid of a Eqs. (15), (32), (41), we get a system of five non-homogeneous equations which can be written as:

$$\sum_{j=1}^5 d_{ij} Z_j = g_i, \tag{42}$$



where  $Z_j$ , ( $j=1, 2, 3, 4, 5$ ) are the ratios of amplitudes of reflected P-, refracted P-, refracted T-, refracted MD- and refracted SV-waves to that of incident wave.

where  $d_{ij}$ , ( $i,j=1,2,3,4$ ) are given in Appendix B.

Here  $p.v.$  is calculated with restriction  $dV_{jl} \geq 0$  to satisfy decay condition in thermoelastic diffusion medium. The coefficients  $g_i$ ,  $i = 1, 2, 3, 4, 5, 6$  on the right side of the Eq. (42) are given by

$$g_1 = -d_{11}, g_2 = d_{21}, g_3 = -d_{31}, g_4 = d_{41}, g_5 = 0. \quad (43)$$

Now we consider a surface element of unit area at the interface between two media. The reason for this consideration is to calculate the partition of energy of the incident wave among the reflected and refracted waves on both sides of the surface. Following Achenbach[36], the energy flux across the surface element, that is, rate at which the energy is communicated per unit area of the surface is represented as:

$$P^* = \sigma_{lm} l_m \dot{u}_l, \quad (44)$$

where  $\sigma_{lm}$  is the stress tensor,  $l_m$  are the direction cosines of the unit normal  $\hat{l}$  outward to the surface element and  $\dot{u}_l$  are the components of the particle velocity.

The time average of  $P^*$  over a period, denoted by  $\langle P^* \rangle$ , represents the average energy transmission per unit surface area per unit time. Thus, on the surface with normal along  $x_3$ -direction, the average energy intensities of the waves in the fluid medium are given by

$$\langle P^{*f} \rangle = \text{Re} \langle p \rangle^f \cdot \text{Re} \langle u_3^f \rangle. \quad (45)$$

Following Achenbach [36], for any two complex functions  $f$  and  $g$ , we have

$$\langle \text{Re}(f) \cdot \text{Re}(g) \rangle = \text{Re}(f \cdot \bar{g}) / 2. \quad (46)$$

The expression for energy ratio  $E_1$  for the reflected  $P$  wave is given by

$$E_1 = -\langle P^{*f} \rangle / \langle P_0^{*f} \rangle, \quad (47)$$

where

$$\langle P^{*f} \rangle = -(\zeta \omega^2 / 2\nu_p^f) |Z_1|^2 \text{Re}(\cos\theta_1), \quad (48)$$

and for incident  $P$ -wave

$$\langle P_0^{*f} \rangle = -(\zeta \omega^2 / 2\nu_p^f) \cos\theta_0, \quad (49)$$

Are the average energy intensities of the reflected  $P$ - and incident  $P$ -, respectively. In Eq. (47), negative sign is taken because the direction of reflected waves is opposite to that of incident wave.

For thermoelastic diffusion solid with DPLT and DPLD models, the average intensities of the waves on the surface with normal along  $x_3$ -direction, are given by

$$\langle P^* \rangle = \text{Re} \langle \sigma_{13}^{(i)} \rangle \cdot \text{Re} \langle \dot{u}_1^{(i)} \rangle + \text{Re} \langle \sigma_{33}^{(i)} \rangle \cdot \text{Re} \langle \dot{u}_3^{(i)} \rangle. \quad (50)$$

The expressions for energy ratios for the refracted P-, refracted T-, refracted MD- and refracted SV- waves are given by

$$E_{ij} = \langle P_{ij}^* \rangle / \langle P_0^{*f} \rangle, i, j = 1, 2, 3, 4 \tag{51}$$

where  $\langle P_{ij}^* \rangle$ ;  $i, j = 1, 2, 3$  are given in Appendix C.

The diagonal entries of energy matrix  $E_{ij}$  in Eq. (51) represents the energy ratios of P, T, MD- SV- waves respectively, whereas sum of the non diagonal entries of  $E_{ij}$  give the share of interaction energy among all refracted waves in the medium and is given by

$$E_{RR} = \sum_{i=1}^3 \left( \sum_{j=1}^3 E_{ij} - E_{ii} \right). \tag{52}$$

The energy ratios  $E_1$ , diagonal entries and non diagonal entries of energy matrix  $E_{ij}$ , that is,  $E_{11}, E_{22}, E_{33}$  and  $E_{RR}$  yield the conservation of incident energy across the interface, through the relation

$$E_1 + E_{11} + E_{22} + E_{33} + E_{44} + E_{RR} = 1. \tag{53}$$

### 7 PARTICULAR CASE

In absence of DPLD model, that is, if we take  $\tau_p = \tau_\eta = 0$  in the Eqs. (42) and (51), we obtain the corresponding expressions for amplitude and energy ratios of reflected P-, refracted P-, refracted T-, refracted MD-, and refracted SV- waves to that of incident wave at the interface of inviscid fluid and thermoelastic with mass diffusion with DPLT model with changed values of constants

$$A = -i\omega\tau_i^{11}\zeta_1, B = -i\omega\tau_q^{11}, I = -i\tau_i^{11}, J = -i\omega\tau_q^{11}\zeta_2, E = q_1^*, F = q_2^*, G = -i\omega q_4^*, H = -q_3^*.$$

In absence of DPLT and DPLD models, that is, if we take  $\tau_q = \tau_i = \tau_p = \tau_\eta = 0$  in the Eqs. (42) and (51), we obtain the corresponding expressions for amplitude and energy ratios of reflected P-, refracted P-, refracted T-, refracted MD-, and refracted SV- waves to that of incident wave at the interface of inviscid fluid and thermoelastic with mass diffusion with changed values of constants

$$A = -i\omega\zeta_1, B = -i\omega, I = -i, J = -i\omega\zeta_2, E = q_1^*, F = q_2^*, G = -i\omega q_4^*, H = -q_3^*.$$

In absence of DPLT, DPLD models and diffusion effect, that is, if we take  $a = b = D = \beta_2 = \tau_q = \tau_i = \tau_p = \tau_\eta = 0$  in the Eqs. (42) and (51), we obtain the corresponding expressions for amplitude and energy ratios of reflected P-, refracted P-, refracted T- and refracted SV- waves to that of incident wave at fluid and thermoelastic solid interface.

The velocities  $V_1$  and  $V_3$  in these expressions are derived from the roots of quadratic equation in  $V^2$ , given by

$$V^4 - \omega(1 + \zeta_1) = 0,$$

and the coupling coefficients  $n_i, i = 1, 3, i=1, 3$  are given as

$$n_i = \left( \omega^2 \zeta_1 / (V^2 - \omega) \right), i = 1, 3$$

## 8 NUMERICAL RESULTS AND DISCUSSION

We now represent some numerical results for copper material (Sherief and Saleh [38]), the physical data for which is given below:

$$\begin{aligned}\lambda &= 7.76 \times 10^{10} \text{ Kg m}^{-1} \text{ s}^{-2}, \mu = 3.86 \times 10^{10} \text{ Kg m}^{-1} \text{ s}^{-2}, T_0 = 0.293 \times 10^3 \text{ K}, \\ C_E &= .3831 \times 10^3 \text{ JK g}^{-1} \text{ K}^{-1}, \alpha_t = 1.78 \times 10^{-5} \text{ K}^{-1}, \alpha_c = 1.98 \times 10^{-4} \text{ Kg}^{-1} \text{ m}^3 \\ a &= 1.2 \times 10^4 \text{ m}^2 \text{ s}^{-2} \text{ K}^{-1}, b = 9 \times 10^5 \text{ Kg}^{-1} \text{ m}^5 \text{ s}^{-2}, D = 0.85 \times 10^{-8} \text{ Kg s m}^{-3}, \\ \rho &= 8.954 \times 10^3 \text{ Kg m}^{-3}, K = 0.383 \times 10^3 \text{ W m}^{-1} \text{ K}^{-1}.\end{aligned}$$

The relaxation times are:

$$\tau_t = 0.1 \text{ s}, \tau_q = 0.3 \text{ s}, \tau_p = 0.2 \text{ s}, \tau_\eta = 0.4 \text{ s}$$

The fluid parameters are taken as:

$$\lambda^f = 2.1904 \times 10^9 \text{ Kg m}^{-1} \text{ s}^{-2}, \rho^f = 1.0 \times 10^3 \text{ Kg m}^{-3} \text{ s}^{-2},$$

The software Matlab 7.0.4 has been used to determine the values of energy ratios  $E_i$  and an energy matrix  $E_{ij}$ ,  $i, j = 1, 2, 3, 4$  defined in previous section for different values of incident angle ( $\theta_0$ ) ranging from  $0$  to  $90^\circ$  for fixed frequency  $\omega = 2 \times \pi \times 100$  Hz. Corresponding to incident  $P$ , the variation of these energy ratios with respect to angle of incidence have been plotted in Figs. 2-7 for the cases of both DPLT and DPLD, DPLT and without DPLD and DPLT models and are represented by horizontal lines, vertical lines and horizontal boxes, respectively. To show the effect of different phase-lag models of thermoelastic diffusion graphs are drawn in 3D.

Fig. 2-7 shows the variation of energy ratios  $E_1, E_{11}, E_{22}, E_{33}, E_{44}$  and  $E_{RR}$  with change in angle of incidence  $\theta_0$  for the following cases:

Case(i)

$$\tau_t = 0.1, \tau_q = 0.2, \tau_p = 0.3, \tau_\eta = 0.4$$

Case(ii)

$$\tau_t = 0.1, \tau_q = 0.2, \tau_p = 0, \tau_\eta = 0$$

Case(iii)

$$\tau_t = 0, \tau_q = 0, \tau_p = 0, \tau_\eta = 0$$

It is clear from Fig. 2 that initially the values of energy ratios  $E_i$  decrease but increase smoothly with increase in angle of incidence  $\theta_0$  for  $\theta_0 \geq 10^\circ$  for all the three cases, but increases sharply as  $\theta_0$  approaches  $90^\circ$  for Case(i) and Case(ii) with difference in their magnitude values as compared to the Case(iii). Fig. 3 indicates that for three cases of phase lag models of thermoelasticity,  $E_{11}$  initially increase with small variation in magnitude values in the range  $0 \leq \theta_0 \leq 70^\circ$  and increases sharply for  $\theta_0 > 70^\circ$ . The maximum value is attained for Case(i) as compared to other cases. Fig. 4 depicts that the values of energy ratios  $E_{22}$  first increase smoothly and sharply for large values of  $\theta_0$ . For Case(i) and Case(ii),  $E_{22}$  attains maximum value as compared to case(i). From Fig.5, It is noticed that behavior and variation of  $E_{33}$  is similar to  $E_{22}$  with difference in their magnitude values. From Fig. 6 it is evident that the values of energy ratio  $E_{44}$  initially decrease for  $0 \leq \theta_0 \leq 10^\circ$  and increases smoothly attaining maximum

value and sharply as  $\theta_0$  approaches  $90^\circ$ . Maximum value of  $E_{44}$  occurs in absence of phase-lag-models. From Fig.7, it is evident that  $E_{RR}$  shows opposite behavior and variation as that of  $E_{11}$  but with different magnitude values. It is noticed that the sum of the values of energy ratios  $E_1, E_{11}, E_{22}, E_{33}, E_{44}$  and  $E_{RR}$  is found to be exactly unity at each value of  $\theta_0$  which proves the law of conservation of energy at the interface. Due to the small values of  $E_{11}, E_{22}, E_{33}$  and  $E_{44}$  their values are magnified by  $10^5, 10^2, 10^4, 10^2$  respectively.

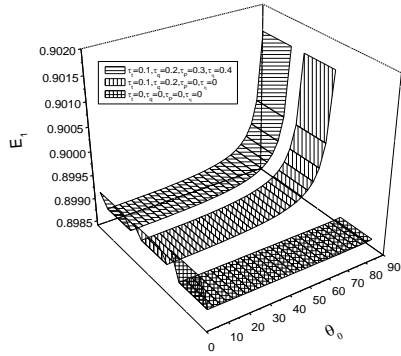

**Fig.2**  
Variation of energy ratio  $E_1$  w.r.t. angle of incidence  $\theta_0$ .

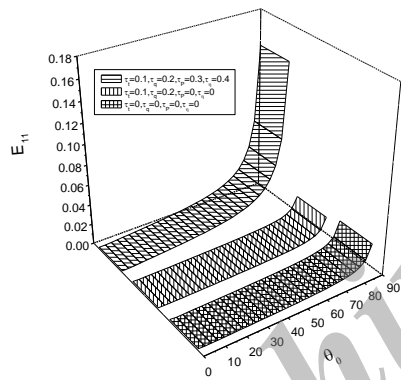

**Fig.3**  
Variation of energy ratio  $E_{11}$  w.r.t. angle of incidence  $\theta_0$ .

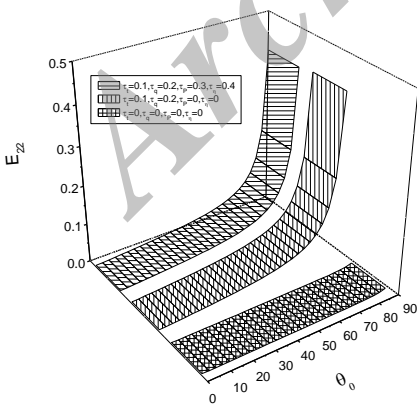

**Fig.4**  
Variation of energy ratio  $E_{22}$  w.r.t. angle of incidence  $\theta_0$ .

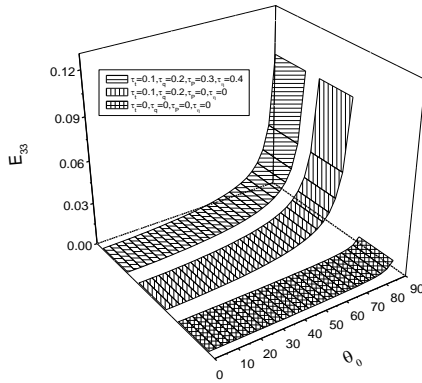

**Fig.5**  
Variation of energy ratio  $E_{33}$  w.r.t. angle of incidence  $\theta_0$ .

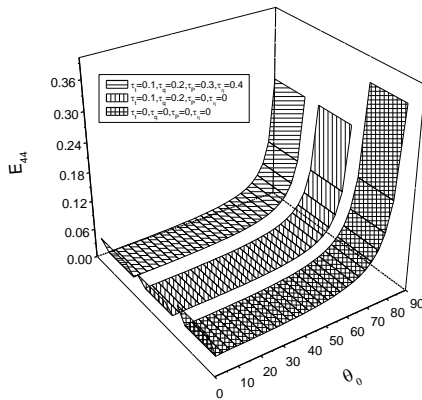

**Fig.6**  
Variation of energy ratio  $E_{44}$  w.r.t. angle of incidence  $\theta_0$ .

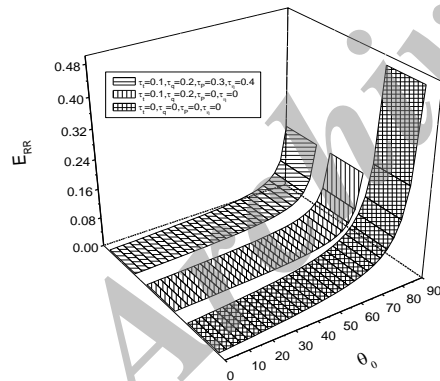

**Fig.7**  
Variation of energy ratio  $E_{RR}$  w.r.t. angle of incidence  $\theta_0$ .

## 9 CONCLUSION

In the present article, the classical Fick's diffusion law is replaced by a generalized form which involves two phase-lags. It allows a delayed response between the relative mass flux vector and the potential gradient. Also the reflection and refraction of obliquely incident elastic wave at the interface between an inviscid fluid half-space and a thermoelastic diffusion solid half-space with phase-lag models (DPLT and DPLD) has been studied. The four waves in thermoelastic diffusion solid medium are identified and explained through different wave equations in terms of displacement potentials. The energy ratios of different reflected and refracted waves to that of incident wave are computed numerically and presented graphically with respect to the angle of incidence for different phase-lag-models. From numerical results, we conclude that the effect of phase lag (DPLT and DPLD) models and diffusion on the energy ratios of the reflected and refracted waves is significant. The sum of all energy ratios of the reflected

waves, refracted waves and interference between refracted waves is verified to be always unity which ensures the law of conservation of incident energy at the interface.

**ACKNOWLEDGMENTS**

One of the authors Vandana Gupta is thankful to Council of Scientific and Industrial Research (CSIR) for the financial support.

**APPENDIX A**

$$n_i = \{(EJ - AH)\omega^4 + AH\omega^2 V_i^2\} / \{B G V_i^4 - (GI + HB - JF)\omega^2 V_i^2 + IH\omega^4\},$$

$$k_i = \{EI\omega^6 - (EB - AF)\omega^4 V_i^2\} / \{V_i^2 (B G V_i^4 - \omega^2 V_i^2 (GI + HB - JF) + IH\omega^4)\},$$

$i = 1, 2, 3.$

**APPENDIX B**

$$d_{11} = -(\rho c_1^2 / \omega), d_{15} = 2\mu(\xi_R / \omega)(dV_4 / \omega), d_{25} = \mu[(\xi_R / \omega)^2 - (dV_4 / \omega)^2],$$

$$d_{31} = idV_\alpha / \omega, d_{35} = -\xi_R / \omega, d_{21} = d_{41} = d_{45} = d_{51} = d_{55} = 0,$$

$$d_{1j} = \lambda(\xi_R / \omega)^2 + (\rho c_1^2)(dV_j / \omega)^2 + (\rho c_1^2 n_j / \omega^2) + (\rho c_1^2 k_j / \omega^2),$$

$$d_{2j} = 2\mu(\xi_R / \omega)(dV_j / \omega), d_{3j} = -dV_j / \omega, d_{4j} = in_j dV_j / \omega,$$

$$d_{5j} = ik_j dV_j / \omega; \quad j = 2, 3, 4$$

$$(dV_\alpha / \omega) = ((1/v_p^2) - (\xi_R / \omega)^2)^{\frac{1}{2}} = ((1/v_p^2) - (\sin^2\theta_0 / V_0^2))^{\frac{1}{2}}.$$

$$(dV_j / \omega) = p v_j \cdot ((1/V_j^2) - (\sin^2\theta_0 / V_0^2))^{\frac{1}{2}}, j = 1, 2, 3, 4.$$

**APPENDIX C**

$$\langle P_{ij}^* \rangle = (-\omega^4 / 2) \text{Re} \left[ \{ 2\mu(dV_i / \omega)(\xi_R / \omega)(\bar{\xi}_R / \omega) + \{ \lambda(\xi_R / \omega)^2 (d\bar{V}_j / \omega) + \rho c_1^2 (dV_i / \omega)^2 \right. \right.$$

$$\left. \left. + (\rho c_1^2 n_i / \omega^2) + (\rho c_1^2 k_i / \omega^2) \} \} Z_{i+2} \bar{Z}_{j+2} \right]$$

$$\langle P_{i4}^* \rangle = (-\omega^4 / 2) \text{Re} \left[ \{ -2\mu(dV_i / \omega)(d\bar{V}_4 / \omega)(\xi_R / \omega) + \right.$$

$$\left. \{ \lambda(\xi_R / \omega)^2 (\bar{\xi}_R / \omega) + \rho c_1^2 (dV_i / \omega)^2 (\bar{\xi}_R / \omega) \} + (\rho c_1^2 n_i / \omega^2) + (\rho c_1^2 k_i / \omega^2) \} \} Z_{i+2} \bar{Z}_6 \right]$$

$$\langle P_{4j}^* \rangle = (-\omega^4 / 2) \text{Re} \left[ \{ \mu((\xi_R / \omega)^2 - (dV_4 / \omega)^2)(\bar{\xi}_R / \omega) + 2\mu(\xi_R / \omega)(dV_4 / \omega)(d\bar{V}_j / \omega) \} Z_6 \bar{Z}_{j+2} \right],$$

$$\langle P_{44}^* \rangle = (-\omega^4 / 2) \text{Re} \left[ \{ \mu((\xi_R / \omega)^2 - (dV_4 / \omega)^2)(d\bar{V}_4 / \omega) + 2\mu(\xi_R / \omega)(\bar{\xi}_R / \omega)(dV_4 / \omega) \} Z_6 \bar{Z}_6 \right]$$

$i, j = 1, 2, 3.$

**REFERENCES**

[1] Biot M.A., 1956, Thermoelasticity and irreversible thermodynamics, *Journal of Applied Physics* **27**: 240-253.  
 [2] Hetnarski R.B., Ignaczak J., 1999, Generalized thermoelasticity, *Journal of Thermal Stresses* **22**: 451- 476.  
 [3] Lord H.W., Shulman Y., 1967, Generalized dynamical theory of thermoelasticity, *Journal of the Mechanics and Physics of Solids* **15**: 299-309.  
 [4] Green A.E., Lindsay K.A., 1972, Thermoelasticity, *Journal of Elasticity* **2**: 1-7.  
 [5] Hetnarski R.B., Ignaczak J., 1996, Solution-like waves in a low temperature non-linear thermoelastic solid , *International Journal of Engineering Science* **34**: 1767-1787.

- [6] Green A.E., Nagdhi P.M., 1992, Thermoelasticity without energy dissipation, *Journal of Elasticity* **31**: 189-208.
- [7] Green A.E., Nagdhi P.M., 1991, A re-examination of the basic postulates of thermomechanics, *Proceedings of the Royal Society of London* **432**: 171-194.
- [8] Tzou D.Y., 1995, A unified field approach for heat conduction from macro to micro Scales, *The ASME Journal of Heat Transfer* **117**: 8-16.
- [9] Chandrasekharaiah D.S., 1998, Hyperbolic thermoelasticity: a review of recent literature, *Applied Mechanics Reviews* **51**: 705-729.
- [10] Roychoudhary S.K., 2007, On a thermoelastic three-phase-lag model, *Journal of Thermal Stresses* **30**: 231-238.
- [11] Sinha S.B., Elsibai K.A., 1997, Reflection and refraction of thermoelastic waves at an interface of two semi-infinite media with two relaxation times, *Journal of Thermal Stresses* **20**: 129-145.
- [12] Kumar R., Sharma J.N., 2005, Reflection of plane waves from the boundaries of a micropolar thermoelastic half space without energy dissipation, *International Journal of Applied Mechanics and Engineering* **10**: 631-645.
- [13] Kumar R., Sarthi P., 2006, Reflection and refraction of thermoelastic plane waves at an interface of two thermoelastic media without energy dissipation, *Archives of Mechanics* **58**: 155-185.
- [14] Kumar R., Singh M., 2007, Propagation of plane waves in thermoelastic cubic material with two relaxation times, *Applied Mathematics and Mechanics* **28**(5): 627-641.
- [15] Kumar R., Kansal T., 2011, Reflection of plane waves at the free surface of a transversely isotropic thermoelastic diffusive solid half-space, *International Journal of Applied Mathematics and Mechanics* **7**(14): 57-78.
- [16] Kumar R., Kansal T., 2012, Reflection and refraction of plane waves at the interface of an elastic solid half-space and a thermoelastic diffusive solid half-space, *Archives of Mechanics* **64**(3): 293-317.
- [17] Podstrigach Ya. S., 1961, Differential equations of the problem of thermodiffusion in a solid deformable isotropic body, *Dop. Akad. Nauk. Ukr. RSR* **2**: 169-172.
- [18] Podstrigach Ya. S., Pavlina V. S., 1965, The differential equations of thermodynamic processes in an n-component solid solution, *Fiziko Khimicheskaya Mekhanika Materialov* **1**(4): 383-389.
- [19] Podstrigach Ya. S., 1964, The diffusion theory of strain of an isotropic solid medium, *Vopr. Mekh. Real. Tver. Tela* **2**: 71-99.
- [20] Podstrigach Ya. S., 1965, The diffusion theory of inelasticity of metals, *Zh. Prikl. Mekh. Tekh. Fiz* **2**: 67-72.
- [21] Podstrigach Ya. S., Pavlina V. S., 1974, Diffusion processes in a viscoelastic deformable body, *Prikl. Mekh* **10**(5): 47-53.
- [22] Podstrigach Ya. S., Pavlina V. S., 1977, Diffusion processes in a viscoelastic deformable layer, *Fiziko Khimicheskaya Mekhanika Materialov* **13**(1): 76-81.
- [23] Podstrigach Ya. S., Shvets R. N., Pavlina V. S., 1971, The quasistatic thermodiffusion problem for deformable solid bodies, *Prikl. Mekh* **7**(12): 11-16.
- [24] Nowacki W., 1974, Dynamical problems of thermodiffusion in solids-I, *Bulletin of Polish Academy of Sciences Series, Science and Technology* **22**: 55-64.
- [25] Nowacki W., 1974, Dynamical problems of thermodiffusion in solids-II, *Bulletin of Polish Academy of Sciences Series, Science and Technology* **22**: 129-135.
- [26] Nowacki W., 1974, Dynamical problems of thermodiffusion in solids-III, *Bulletin of Polish Academy of Sciences Series, Science and Technology* **22**: 275-276.
- [27] Nowacki W., 1976, Dynamical problems of diffusion in solids, *Engineering Fracture Mechanics* **8**: 261-266.
- [28] Dudziak W., Kowalski S.J., 1989, Theory of thermodiffusion for solids, *International Journal of Heat and Mass transfer* **32**: 2005-2013.
- [29] Olesiak Z.S., Pyryev Y.A., 1995, A coupled quasi-stationary problem of thermodiffusion for an elastic cylinder, *International Journal of Engineering Science* **33**: 773-780.
- [30] Gawinecki J.A., Szymaniec A., 2002, Global solution of the cauchy problem in nonlinear thermoelastic diffusion in solid body, *Proceedings in Applied Mathematics and Mechanics* **1**: 446-447.
- [31] Wu J., Zhu Z., 1992, The propagation of Lamb waves in a plate bordered with layers of a liquid, *The Journal of the Acoustical Society of America* **91**: 861-867.
- [32] Sharma J.N., Kumar S., Sharma Y.D., 2008, Propagation of rayleigh waves in microstretch thermoelastic continua under inviscid fluid loadings, *Journal of Thermal Stresses* **31**: 18-39.
- [33] Kumar R., Pratap G., 2009, Wave propagation in microstretch thermoelastic plate bordered with layers of inviscid liquid, *Multidiscipline Modeling in Materials and Structures* **5**: 171-184.
- [34] Sharma M.D., 2004, 3-D wave propagation in a general anisotropic poroelastic medium: reflection and refraction at an interface with fluid, *Geophysical Journal International* **157**: 947-958.
- [35] Sherief H.H., Hamza F.A. Saleh H.A., 2004, The theory of generalized thermoelastic diffusion, *The International Journal of Engineering Science* **42**: 591-608.
- [36] Achenbach J.D., 1973, *Wave Propagation in Elastic Solids*, North-Holland, Amsterdam.
- [37] Borchardt R.D., 1982, Reflection-refraction of general P and type-I S waves in elastic and anelastic solids, *Geophysical Journal of Royal Astronomical Society* **70**: 621-638.
- [38] Sherief H.H., Saleh H.A., 2005, A half space problem in the theory of thermoelastic diffusion, *International Journal of Solid and Structures* **42**: 4484-4493.