



SEISMIC EVALUATION OF PIPE RACK SUPPORTING STRUCTURES IN A PETROCHEMICAL COMPLEX IN IRAN

Mohammad Karimi¹, Naghdali Hosseinzadeh², Farshid Hosseini³, Navid Kazem⁴, Hamid Kazem⁵

^{1,2}*International Institute of Earthquake Engineering and Seismology, Tehran, Iran*

^{3,4}*Department of Civil Engineering, Sharif University of Technology, Tehran, Iran*

⁵*Department of Civil Engineering, Amirkabir University of Technology, Tehran, Iran*

Received 8 February 2011

Revised 23 April 2011

Accepted May 12 2011

Seismic evaluation of pipe rack supporting structures in a petrochemical complex as one of the most important parts of structural systems for safe and stable production processes have been studied in this paper. The behavior of these supporting structures is similar to steel or reinforced concrete frame supporters for elevated processing pipes. Qualitative and quantitative methods of seismic vulnerability evaluations have been used according to the ASCE-1998 standards. In qualitative evaluation, the seismic vulnerability factors are determined by visual inspections and walk down the structural systems. Computer modelings have been used in quantitative evaluation of the supporting structures, including equivalent static analysis and linear dynamic analysis by considering torsion and P- Δ effects. Site specific earthquake records and design spectrum have been used as input seismic forces. Also, gravity and thermal loads based on the existing documents and design calculation sheets and specification notes have been considered in the analyses. Gravity and lateral load combinations have been considered for seismic evaluation of foundation systems. Overturning stability of structures and uplifting of foundation systems due to the gravity and lateral loads, and also, lateral displacements, frame element and connection capacities have been investigated. However, different methods of seismic strengthening and retrofitting of structural system have been proposed.

¹ M.Sc. Graduate

² Assistant Professor

^{3,5} M.Sc. Student

⁴ B.Sc. Student

Keywords: pipe rack, seismic vulnerability, static and dynamic analysis, petrochemical complex, supporting structure

1. Introduction

Considering the seismic potential in different parts of the country, risk estimating and seismic vulnerability studies and recommending suitable methods for retrofitting various industrial centers such as refineries, power plants, petrochemical complexes are of vital importance. These centers are usually equipped with sophisticated equipment such as piping systems, pressure storages and sensitive buildings that as a result can be susceptible to severe damages in the event of a strong earthquake.

The pipe supporting structures are actually structures that support pipes used in industrial areas such as refineries and petrochemical plants in order to enhance their reach site's different parts. It is possible that in addition to pipes, electric cables and equipment lines will also rely on these structures and in some cases equipment such as air fans are placed on pipe supporting structures. Also, if necessary to reach places such as taps or repair areas, platforms will be placed.

2. Assessment Procedures of Pipe Supporting Structures

Considering the complicated piping system in petrochemical complexes, analytical studies of structures aren't enough and possible to gauge vulnerability of the structures during an earthquake. Therefore, field assessments in a petrochemical plant are of special importance. In general, vulnerability assessments consist of two main stages. The first stage is qualitative studies which consist of field assessments and the second stage contains quantitative studies that include computer analysis.

Field assessments include direct and indirect checking of assessor engineer that consist of collection of all available information and previous inspections. In qualitative procedure with respect to evaluation of vulnerability of pipe supporting structures, ASCE98 guideline procedures are utilized. Assessment starts with completion vulnerability inspection of guideline forms and using past earthquakes experiences. With completion and inspection of these forms we can form an opinion regarding the pipe route's vulnerability in face of seismic loads. Considering the complexity and the number of pipes, direction of aerial pipes, meshed in parts which have approximately equal vulnerability condition in facing seismic loads. Superficial specifications, seat and supporting status, interaction status, and support condition of structures are some of the points covered in these check lists.

In quantitative analyses stage, initially, risk of earthquake is assessed and structural specifications are determined. Hence, through computer simulation, the structural ability under incoming seismic loads is investigated and as needed, possible reinforcements would be recommended.

As for the concerned complex, there are 9 pipe supporting structures that are studied and one sample of these studies specifications is presented. In preparation of studies steps, different national and international codes and guidelines are used.

3. Qualitative Assessments

The sample structure is a steel structure with total height of 6.5 meters. The seismic resisting system in cross direction is steel moment frame and in longitudinal direction is concentrically braced frame (CBF). The length of the structure is 36 meters and has one 9 meter span in width. This structure established for holding inside pipes. The ground level has a slope of 8.23% at unit that based on inspections, structure has no chance of collision with adjacent structures therefore it can be modeled separately. In Figure 1 a sample view of the structure can be observed. Similarly, characteristics of construction materials and sections of columns and beams are presented as in Table 1 and Table 2.

4. Quantitative Assessments

4.1. Seismic Hazard Assessment and Design Acceleration Spectrum Definition

Risk of an earthquake is assessed according to the latest seismicity data exists in the area and studies on earthquake sources by using probabilistic approach method (PSHA). In order to estimate maximum values of acceleration (PGA), utilizing probable procedures with possible outcome 2% in 50 years and 64% in 50 years are concluded. In these methods using attenuation relations are obligatory, different relations such as Zareh (1999), AmberSeas (1995), Boore-Joyner-Fumal (1993) and Zareh (2004) are being used.



Figure 1. A view of pipe supporting structure

Table 1. Characteristics of construction materials (Kg/cm²)

Elasticity module	Bars		Concrete Pressure resistance	Steel		
	Final resistance	Yielding stress		Elasticity module	Final resistance	Yielding stress
2.03*10 ⁶	6000	4200	300	2.03*10 ⁶	3700	2400

Table 2. Beams and columns section

Section	Element Type
W6X20	Beam
W8X18	Beam
W8X31	Beam
W10X26	Beam
W10X39	Beam
W21X62	Beam
PIPE6STD	Beam
PIPE6STD	Brace
W6X20	Column
W8X18	Column
W14X90	Column
PEDESTAL	Column

Earth acceleration is specified by response spectrum and its coefficients. This acceleration is determined based on the standard response spectrum and site response spectrum where possible earthquakes can occur with probability of 10% in a period of 50 years. Considering the geographical location of the petrochemical unit and the earthquake risk zone, the complex under study is located in the relative high danger zone and relative acceleration of 0.3g. Site ground is assessed as type III that represents standard design spectrum based on standard No.2800 similar to Figure 2. In order to attain site response spectrum, values of design spectra for horizontal and vertical components are assessed by acceleration recorded data processing and estimation of response spectra for different damping ratios of 0.5%, 2%, 5%, and 10% similar to Figure 3.

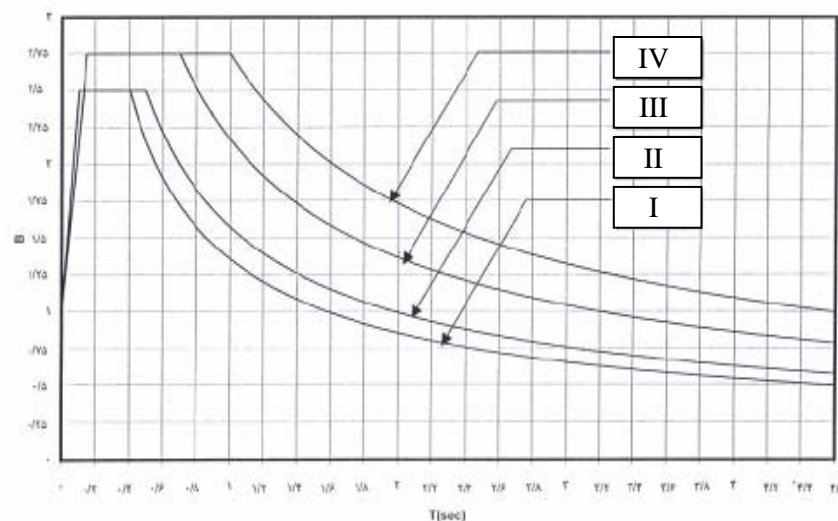

Figure 2. Standard response spectrum chart

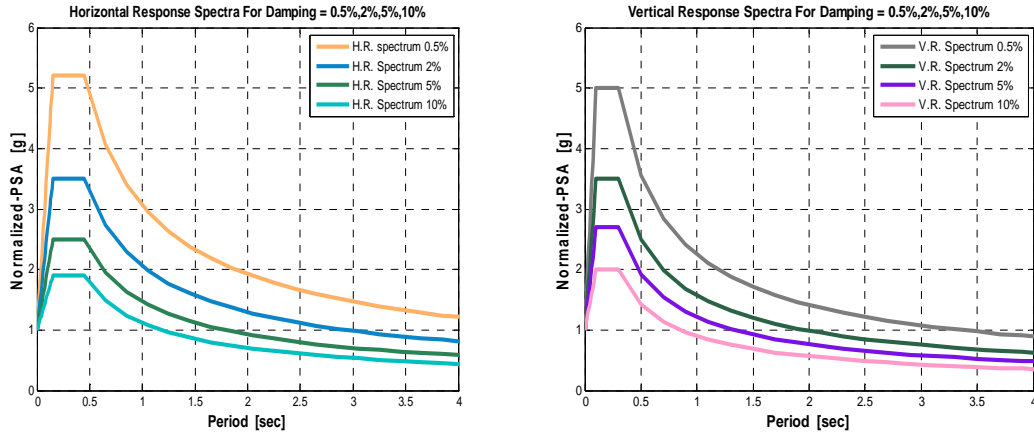

Figure 3. Site's horizontal and vertical spectra for (0.5, 2, 5, and 10%) of damping ratios

4.2. Computer Modelling

Main structure modeling is done using ETABS program to investigate structural features factors such as resistance, stiffness, ductility, damping ratio, dynamic response affected by the earthquake. Investigation of connections adequacy is generally done with manual calculation and in order to certify structure practical functions, it will be modeled again after retrofitting completion. Allowable stresses method is used in controlling the structure and concrete part of structure is examined by ACI318-02 building code. Loading components of steel structure are based on AISC-ASD code. It should be mentioned that element allowable stress in condition of load component according to guideline for seismic evaluation and design of petrochemical facilities ASCE98, increases upto 60 %. Since P- Δ effect should be considered in analyses, loads and displacements are calculated by considering this effect.

According to ASCE98, the above-mentioned structure should be recognized as irregular in both plan and height. Irregularities in plan make torsion and additional forces in force carrier elements. In order to consider torsion forces in model, we should prevent considering ceilings as a diaphragm. Irregularities in height result in noticeable forces to some force carrier elements. Loads applied to structure are dead and thermal loads, live loads (there is no live load in this case) and earthquake loads. 3D model designed by EATABS is observable in Figure 4.

Pipe supporting structure foundation is single type with 60 cm thickness. Concrete pressure resistance and foundation's bars yielding stress are considered 300 and 4000 kg/cm² respectively. In foundation modeling, SAFE software with respect to loading components for controlling foundation carrying capacity and soil pressure is used. 3D model of structure is shown in Figure 5.

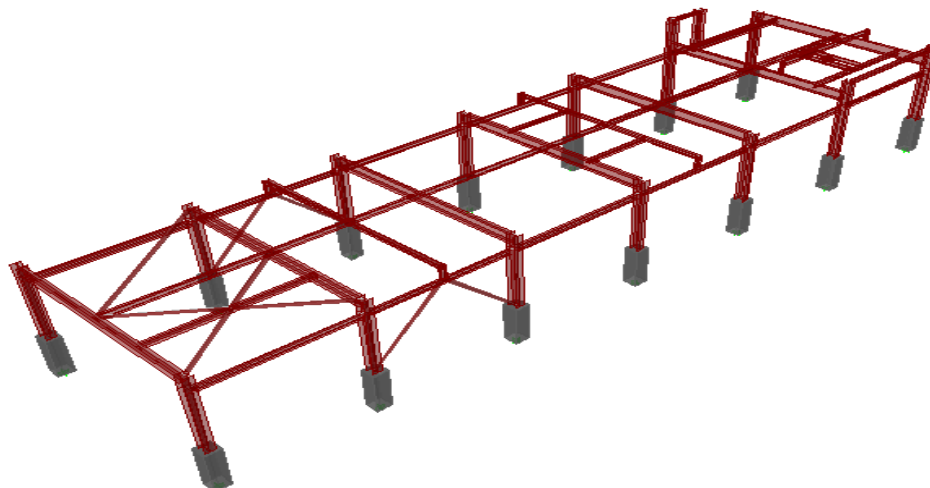

Figure 4. Pipe supporting structure 3D model in ETABS

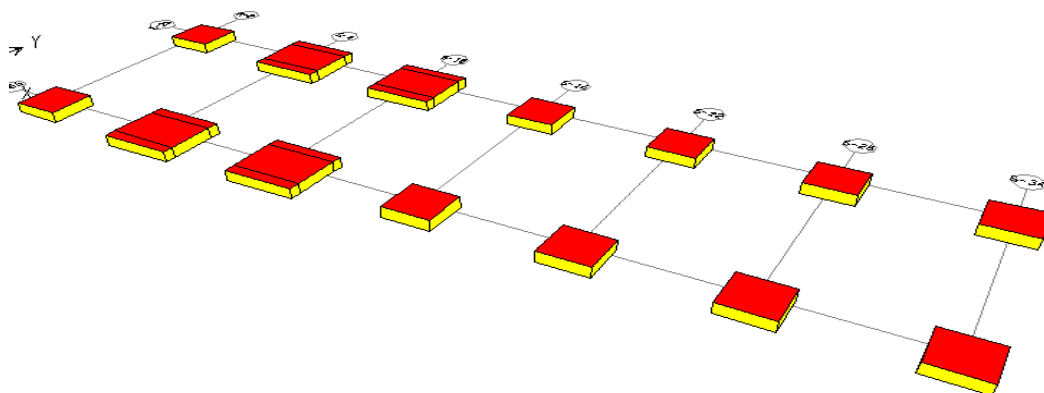

Figure 5. Pipe supporting structure foundation 3D model in SAFE

3.4. Seismic Analysis of Static and Linear Dynamic

This structure is categorized in semi-building structures and since soil is recognized as type III in standard No.2800, dynamic linear analysis is imperative. According standard No.2800, base shear by dynamic method should equal static method. Thus base shear in equivalent static method must be calculated. Seismic parameters related to the equivalent static analysis in order to calculate the base shear has been compiled in Table-3. According to calculations done, seismic weight of structure is estimated about 158 tons that according to Earthquake coefficient obtained, led to base shear about 38 ton.

Table 3. Equivalent static analysis seismic parameters

A	I	R	B	Ty (sec)	Tx (sec)	C
0.39	1.25	5	2.5	0.2	0.32 sec	0.24

In linear dynamic (spectrum) analysis method, structural analysis assuming a linear behavior of material is performed and the various modes are set to be determined. In order to consider number of effective modes in each of the two building directions, maximum mode numbers between three status of vibration modes with time period more than 0.4 second, first three vibration cases and modes with total effective weights more than %90 of structure weight are selected. Also with respect to structure irregularities, reflective values are multiplied in %90 of static base shear proportions with dynamic analysis base shear. In order to consider the greatest earthquake effects on semi-building structures, %100 of earthquake force in each extension with %30 of earthquake in perpendicular extension is applied synchronically on structure. In Table-4, there are some comparisons in base shear required from two procedures.

Table 4. Comparison of base shears from linear dynamic and static methods

Load Case	V _x (Ton)	V _y (Ton)
EX	38	0
EY	0	38
Spec X	13.12	0.24
Spec Y	0.24	13.4

4.4. Modelling Results and Pipe Supporting Structure Controls

In structure analyzing, since columns consist of steel and concrete, the analysis is done in two phases; in first phase, the steel structure, that forms the largest part, was analyzed and in second part, concrete pedestals were analyzed.

Analyzing results indicate that maximum relative movement of structure is 1.29 cm in height of 6.50 m in longitudinal extension. Also maximum relative drift in longitudinal extension is 0.0049 and in transversal extension is 0.00377 that is less than permissible amount of 0.01. In elements tension calculations, maximum tension proportion in steel columns is 0.398, in beams is 0.818, in braces is 0.528 and maximum interactional proportion in pedestals is 1.271. Therefore in terms of capacity, structure's pedestals are diagnosed as weak and vulnerable. In controlling the connections, manual calculations are done. These controlling calculations consist of brace connections to column and beam, roof brace connections, beam connections to column and base plate connections that investigations indicate their appropriate conditions. Foundation analysis results indicate that maximum soil settlement from loading components is 0.48 cm that is in permissible range. Maximum tension resulting from loading components is 0.98 kg/cm² that is less than permissible amount 1.6 kg/cm² and is acceptable. In foundations, bars calculations in X extension indicate that maximum bar area required in bottom section is 6.69 cm² and in above section is 3.3 cm². Meanwhile bars existing areas are 56 cm² in bottom and 36 cm² in the above section that is reasonable. These conditions are confirmed in Y extension and foundation bars in this extension are in permissible range.

After studying the check lists in qualitative researches stage and quantitative studies with computer and manual methods, it is concluded that structure in respect of element capacity has appropriate conditions, connections are reasonable and lateral displacements under seismic loads are in permissible range. Foundation is reasonable in respect of soil tensions and just some cases of steel pedestals under structure's braces are vulnerable. Thus under examinations, structure can be recognized as vulnerable.

4.5. Seismic Retrofitting

Existing vulnerability in pipe supporting structure is dominant, for the reason of pedestals weakness which exists under columns with braces. These pedestals are in shape of square with 60cm dimensions and 2.2m height that has 8 ϕ 20 bars. The most critical condition of pedestals in vulnerable structure is indicated in Figure 6.



Figure 6. Critical condition of pedestals

According to vulnerability of pedestals and their hidden situation in soil, direct strengthen of these elements is very difficult. A suitable way to eliminate elements weakness is decreasing applying loads to them. For this purpose we can install brace or bracket in one of longitudinal spans.

Regarding the environment pollution in petrochemical complex and dangerous of chemical materials and staying away from risky performances, using whole welded connections are not recommended except in cases that using weld is inevitable and should be used. About pipes transmission or existing equipment, installing new braces in structure is impossible. Therefore we can use brackets in longitudinal spans instead of braces. Thus regarding the existing situation and mentioned limitations, bracket installation with PIPE 6STD section and with slenderness ratio of 61 is suggested that is illustrated in Figure 7.

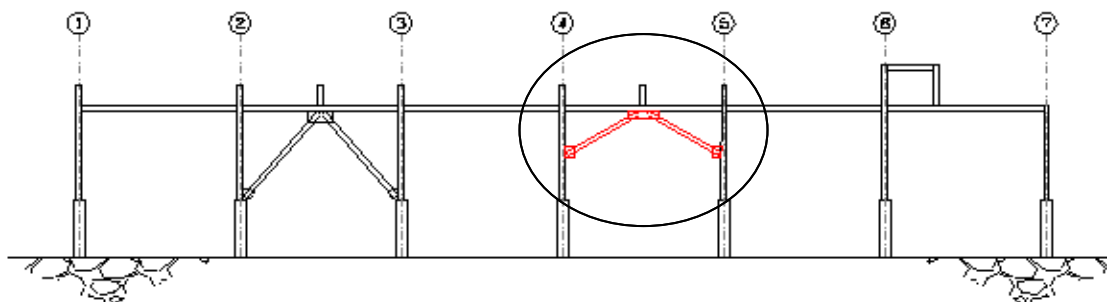

Figure 7. Suggested picket position

After applying changes in basic structure and re-analysis of retrofitted structure, maximum proportion tension decreases from 1.273 to 0.913. Pedestal's tension proportion after bracket installation is illustrated in Figure 8. It is noticeable that if various procedures are applicable for retrofitting, after examining effects of applying forces and economical facilities, best optimization method would be represented.

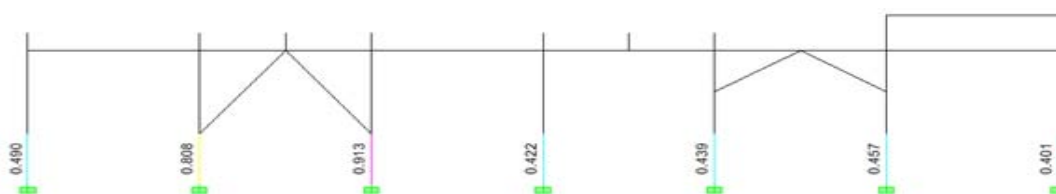

Figure 8. Pedestal's tension proportion on retrofitted structure

5. Conclusions

In the present studies, 9 samples of pipe supporting structures in petrochemical complex were studied. Since design methods and environmental conditions of these kinds of structures are similar to each other, we can generalize the results to similar cases. Studies indicate that initial designing of these structures connections was appropriate and most of the connections breaking down happen for environmental factors such as corrosion. Lateral displacements of these structures caused by seismic loads are reasonable and designs supply codes limitations. Also, these structures foundations are generally appropriate with respect of tension conditions and capability. Thus we can conclude that the most problematic part of pipe supporting structures is in their lateral load resistance system. Braces generally have large slenderness ratio and are vulnerable during earthquakes. Lateral resistance system connections aren't very suitable and should be modified in general. In many cases we should add middle gussets to braces, and in some cases, some elements especially adjacent elements of braces don't have sufficient capacity because of non-existence of lateral resistance system. Now for improving the weakness of lateral

load resistance systems, we can add new systems or strengthen existing systems. Adding shear walls is another option that can be considered in strengthening of lateral load resisting system.

References

American Committee 318 (1997), "Building Code Requirement for Structural Concrete and Commentary (ACI318-02)", *American Concrete Institute*, Farmington Hills, MI, USA.

American Society of Civil Engineers (1998), "Guidelines for Seismic Evaluation and Design of Petrochemical Facilities", *ASCE*, New York, NY., USA.

American Society of Civil Engineers (1998), "Specification for Structural Steel Buildings-Allowable Stress Design and Plastic Design", *ASCE*, New York, NY., USA.

Building and Housing Research Center, "National Building Code of Iran - Provision for Applied Loads on Building (Code No. 6)", *BHRC*, Tehran, Iran.

Building and Housing Research Center, "National Building Code of Iran - Provision for Structural Concrete (Code No. 9)", *BHRC*, Tehran, Iran.

Building and Housing Research Center, "National Building Code of Iran - Provision for Structural Steel (Code No. 10)", *BHRC*, Tehran, Iran.

Committee of Iranian Seismic Design Code (2005), "Iranian Code of Practice for Seismic Resistant Design of Buildings (Standard 2800)", *Building and Housing Research Center*, Tehran, Iran.

Iranian National Oil Company, "Iranian Seismic Design Code of Oil Industry Facilities and Structures (Publication No. 038)", Tehran, Iran.