

# Improvement of open and semi-open core wall system in tall buildings by closing of the core section in the last story

A. Kheyroddin · D. Abdollahzadeh ·  
M. Mastali

Received: 5 October 2013 / Accepted: 25 June 2014 / Published online: 7 August 2014  
© The Author(s) 2014. This article is published with open access at Springerlink.com

**Abstract** Increasing number of tall buildings in urban population caused development of tall building structures. One of the main lateral load resistant systems is core wall system in high-rise buildings. Core wall system has two important behavioral aspects where the first aspect is related to reduce the lateral displacement by the core bending resistance and the second is governed by increasing of the torsional resistance and core warping of buildings. In this study, the effects of closed section core in the last story have been considered on the behavior of models. Regarding this, all analyses were performed by ETABS 9.2.v software (Wilson and Habibullah). Considering (a) drift and rotation of the core over height of buildings, (b) total and warping stress in the core body, (c) shear in beams due to warping stress, (d) effect of closing last story on period of models in various modes, (e) relative displacement between walls in the core system and (f) site effects in far and near field of fault by UBC97 spectra on base shear coefficient showed that the bimoment in open core is negative in the last quarter of building and it is similar to wall-frame structures. Furthermore, analytical results revealed that closed section core in the last story improves behavior of the last quarter of structure height,

since closing of core section in the last story does not have significant effect on reducing base shear value in near and far field of active faults.

**Keywords** Core wall behavior · Warping stress · Torsional resistance · Closed section core · Tall buildings

## Introduction

The rapid growth of the urban population and consequent pressure on limited space has considerably influenced city residential development. The high cost of land, the desire to avoid a continuous urban sprawl, and the need to preserve important agricultural production have all contributed to drive residential buildings upward. Now, high-rise building becomes one of the impressive reflections of today's civilization. The outlook of cities all over the world changes with these tall and slender structures (Stafford Smith and Coull 1991). One of the design criteria for selecting a structural system in tall buildings is stability of these structures under the lateral loads. Shear walls may be used in internal, external or surround internal service areas to form cores (Stafford Smith and Coull 1991). The placement and dimension are main design parameters. Since, the external appearance of building can be influenced by the internal placement of core walls (Stafford Smith and Coull 1991). In the early formative stages of design, quick structural appraisal of alternative shear walls will be required followed by careful design and analysis of the final arrangement (Stafford Smith and Coull 1991). Figure 1 shows single core and multi-cell cores which are divided into two parts: (a) open core; (b) semi-open core which is coupled with connecting beams and floor slabs (Stafford Smith and Coull 1991).

---

A. Kheyroddin  
Department of Civil Engineering, Semnan University, Semnan,  
Iran  
e-mail: kheyroddin@semnan.ac.ir

D. Abdollahzadeh  
Faculty of Engineering, Islamic Azad University of Pardis,  
16555-135 Tehran, Iran

M. Mastali (✉)  
ISISE, Department of Civil Engineering, Campus de Azurem,  
Minho University, 4800-058 Guimaraes, Portugal  
e-mail: M.Mastali@civil.uminho.pt

**Fig. 1** Three types of core wall system, **a** open core wall system, **b** semi-open core wall system by link beams and **c** semi-open core wall system by floor slabs (Stafford Smith and Coull 1991)

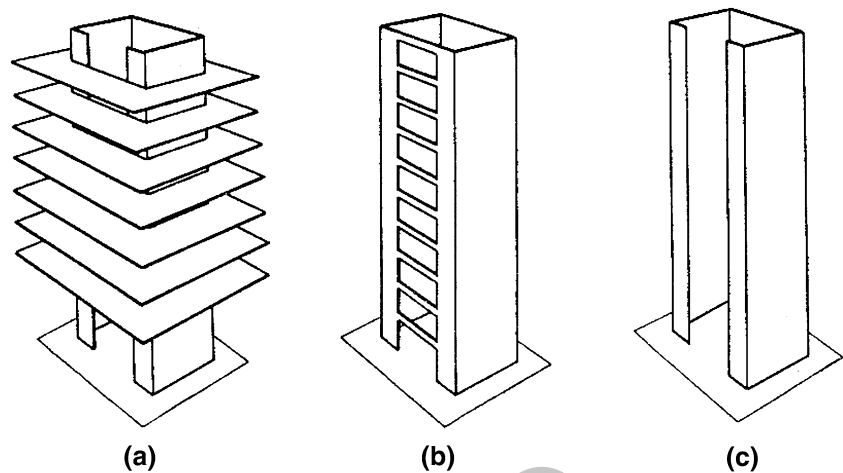

Due to superabundant usage of core wall systems in high-rise buildings, some researchers such as Emsen et al. (2009) have studied on the behavior of core wall systems. Their studies focused on the static analysis of non-planar coupled shear walls with any number of stiffening beams. They found that the stiffening of coupled shear walls decreases the maximum displacement at the top and the maximum bending moment at the bottom of a building. Thus, utilizing such stiffening beams in heights of buildings can be increased more. The stiffening of coupled shear walls can be realized by placing high connecting beams at the levels of whole or partial stories which are used as storage or service areas (Emsen et al. 2009). In addition, the recent study conducted by Mendis (2001) showed that when a substantial torsional moment is present, the magnitude of the longitudinal stresses on the core walls due to warping and the header beam forces is quite significantly high and those actions are too large to be neglected (Mendis 2001). Swaddiwudhipong et al. (2002) demonstrated that the effect of axial deformation should be considered for tall and/or slender buildings. Furthermore, the effect of axial force in columns should be included for structures under high column load, which may occur for buildings with soft stories. This phenomenon could be related to the termination of shear walls in the lower portion of the building (Swaddiwudhipong et al. 2002). In 2009, K.A. Zalka indicated that the interaction between the bending and shear modes is always beneficial, so that it reduces the deflection of the structure (Zalka 2009).

In tall building, core wall system has two important tasks. First task is governed to restraint on the lateral displacement by the core bending resistance and the second task is related to restraint on the torsion of building by torsion resistance and core warping (Fig. 2). At any level of core, the torque  $T[=T(z)]$  is resisted internally by a couple  $T_w(z)$  resulting from the shears in the flanges and associated with their in-plane bending, and a couple

$T_v(z)$  resulting from shear stresses circulating within the section and associated with the twisting of the flanges Eq. (1) (Stafford Smith and Coull 1991).

$$T_w(\mathbf{z}) + T_v(\mathbf{z}) = T(\mathbf{z}) \quad (1)$$

In this study, the effects of closed section on the last story have been considered on the behavior of models. These effects include: (a) drift and rotation of the core over height of buildings, (b) total and warping stress in the core body, (c) shear in beams due to warping stress, (d) effect of closing last story on period of models in various modes, and (e) relative displacement between walls in the core system.

### Modeling

In this study, four structural models considered to assess the effect of closed section core in the last story. All models had 20 stories, in which the height of each level was 3.5 m. Plan and its dimensions are illustrated in Fig. 3. Lateral resisting system in Model A is a two-cell open core (Fig. 4), and its details are illustrated in section B–B in Fig. 3. Model B included a two-cell semi-open core, as shown in Fig. 5. Model C is a two-cell core model, which is closed in the last story by wall, and its details are illustrated in section B–B in Figs. 3 and 6. Fourth model is Model D which is similar to Model B, which consists of a core wall system closed by link beams and a concrete wall in the last story of building (Fig. 7). For static analysis, all models reconsidered under effect of uniform lateral load at structure height and the applied uniform load intensity was  $1.8 \text{ kN/m}^2$ . All calculations were performed using the linear static and dynamic analysis program ETABS 9.2.v (Wilson and Habibullah). Beam depth, wall dimensions, concrete and steel properties are listed in Table 1.

Some simplifications were considered in modeling of buildings: (a) the floor slab is assumed to act as absolutely

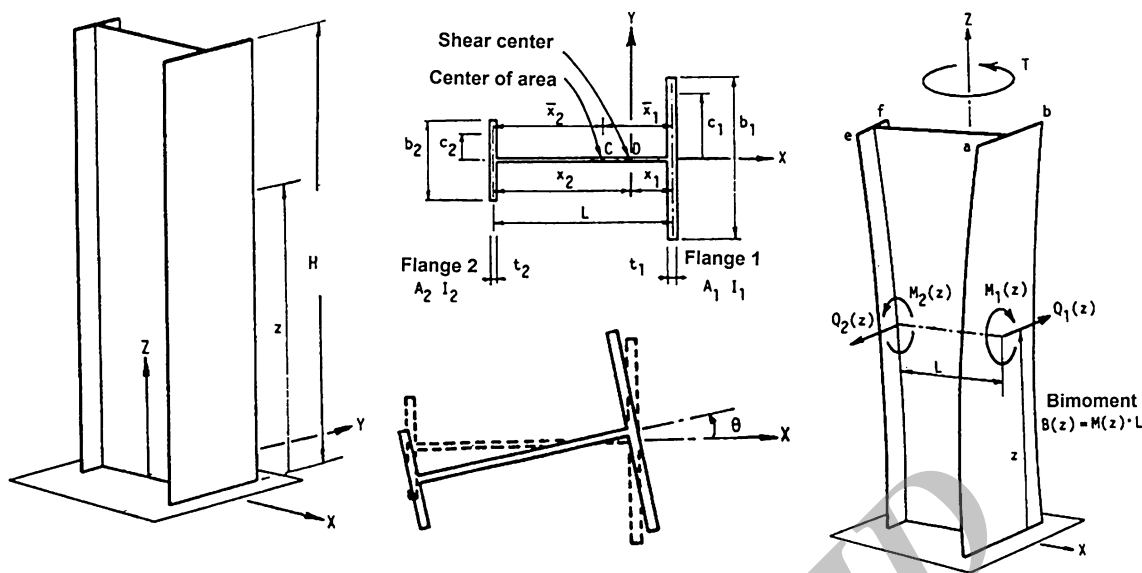

Fig. 2 Core section under effect of torque (Stafford Smith and Coull 1991)

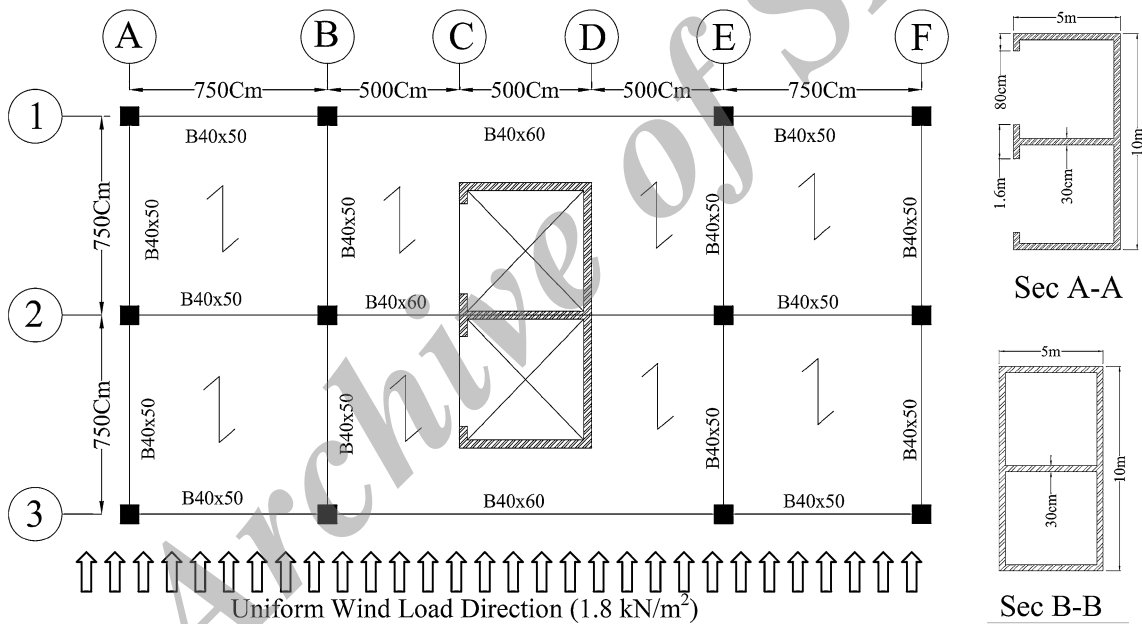

Fig. 3 Building plan and core wall section dimensions

rigid diaphragms (no in-plan deformation); (b) flexural as well as axial, shear and torsion deformation in line elements have been taken into account; and (c) small eccentricities in the connections of beams and columns were neglected.

**Results and discussions**

For statical analysis, all models are analyzed under effect of uniform pressure load with intensity of 1.8 kN/m<sup>2</sup> over

the structure height. Four structural models are analyzed with linear static method to consider the warping stress and axial force in core wall system. Table 2 shows total and warping stresses on some positions of the core sides. Figure 8a illustrates different positions of core wall system. For instance, total stress at base of building of model A is shown by highlighted row in Table 2 and its diagram is plotted in Fig. 8b.

In the present study, the effects of additional wall in the last story of core wall system on warping stress, link beam shear, stories drift, stories rotation, and the maximum stress

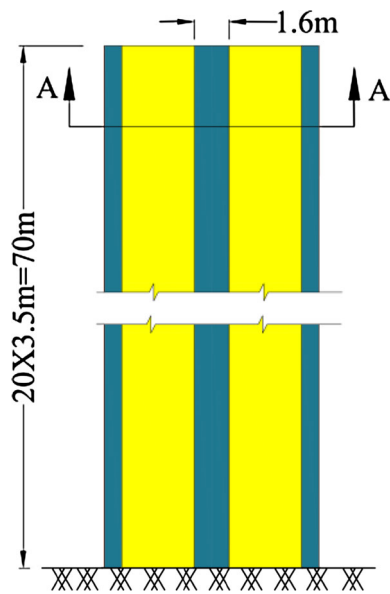

Fig. 4 Elevation of core in Model A

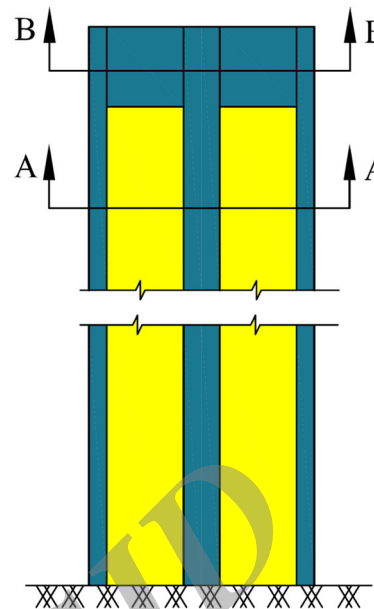

Fig. 6 Elevation of core in Model C

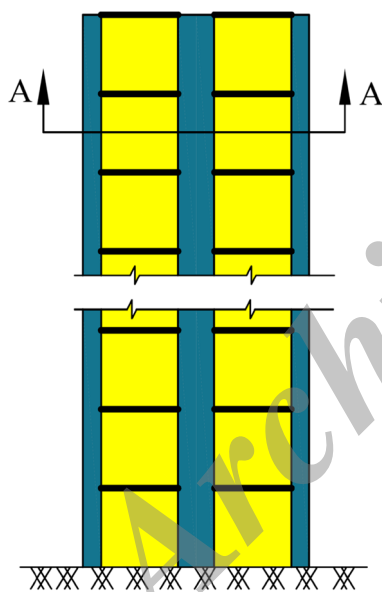

Fig. 5 Elevation of core in Model B

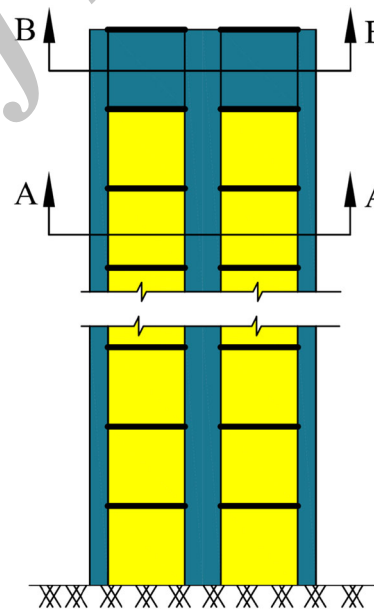

Fig. 7 Elevation of core in Model D

concentration at the base level of core are considered. The results show that behavior of building in model type B is similar to a box in bending and it is due to link beams. Building Model A shows a centralization of stress at corners of core. According to the theory of elasticity, torsion in core section causes an axial stress in tall buildings (Fig. 9). Figure 10 shows the maximum axial stress in core wall system which occurs at corner of wall in the positions B and H. Furthermore, results show that at the top level of buildings, bending stress values are lower than those in the

Table 1 Material properties

Beam depth	500 mm
Specific gravity of concrete	24.525 kPa
Poisson's ratio	0.17
Wall thickness	300 mm
Pressure strength of concrete	$f_c = 24.525$ MPa
Yielding resistance of steel	$f_y = 392.4$ MPa
Elastic modulus of steel	$E = 2.5 \times 10^4$ MPa

**Table 2** Total and warping stress (MPa) in the positions showed in Fig. 7

	Total stress										Story level						
	Warping stress																
	H	G	F	E	D	C	B	A	H	G	F	E	D	C	B	A	
<b>Building A</b>																	
5.10	-0.95	1.08	-9.82	3.09	-3.09	9.82	-5.10	6.82	11.02	11.02	-6.71	4.88	-4.88	6.71	-11.02	1.93	Base
			1.61	-0.54	0.54	-1.61	0.95	-1.08	0.88	1.25	1.81	-0.57	0.57	-1.81	0.88	-1.25	17th st
<b>Building B</b>																	
3.13	-0.61	0.73	-5.87	1.86	-1.86	5.87	-3.13	4.08	9.03	0.84	-2.69	3.56	-3.56	2.69	-9.03	-0.84	Base
			1.02	-0.31	0.31	-1.02	0.61	-0.73	-0.53	0.89	1.22	-0.33	0.33	-1.22	0.53	-0.89	17th st
<b>Building C</b>																	
5.01	-1.98	2.38	-9.51	3.01	-3.01	9.51	-5.01	6.56	10.94	-1.66	-6.44	4.81	-4.81	6.44	-10.94	1.66	Base
			3.70	-1.22	1.22	-3.70	1.98	-2.38	-1.90	2.54	3.90	-1.26	1.26	-3.90	1.90	-2.54	17th st
<b>Building D</b>																	
3.14	-0.92	1.11	-4.07	1.83	-1.83	4.07	-3.14	4.07	9.04	0.86	-2.67	3.56	-3.56	2.67	-9.04	-0.86	Base
			1.66	-0.51	0.51	-1.66	0.92	-1.11	-0.84	1.28	1.86	-0.54	0.54	-1.86	0.84	-1.28	17th st

base levels. It shows that buildings have a cantilever box-like behavior in bending.

Considering average warping stress in Table 2 showed that warping stress in Model B was 38 % lower than that in Model A and also direction of stress at level of 17th story is reverse of the direction of stress at base. This case can be considered as wall-frame interaction. On the other hand, at top of the core structure, the core has more negative stresses in comparison to the base level of buildings.

Closed section effects on bimoment

In this section, the effects of additional wall in the last story of models are considered. Figure 12 is a bimoment diagram for Model D, which is obtained from Eq. 2. All bimoment calculations are shown in Table 3. Figure 11 shows sectorial coordinate of the core in Model A. According to Fig. 12, bimoment value has a negative value in the last quarter of structure height. It shows that the core warping in Model A has no positive effects on torsional resistance in the latest stories of tall buildings. In addition, negative bimoment value increases the last story rotation. To review the negative bimoment effects on the story rotation in the last quarter of structure height, relative stories rotation is plotted for all models and a model without core wall system (Frame). Bimoment under structure height presented by Eq. 2 (Stafford Smith and Coull 1991).

$$B(z) = -m.H^2 \times \left\{ \frac{1}{(\alpha H)^2} \left[ \frac{(\alpha H \sinh \alpha H + 1)}{\cosh \alpha H} (\cosh \alpha z) - \alpha H \sinh \alpha z - 1 \right] \right\} \tag{2}$$

Considering the relative story rotation in Model A and a single frame in Fig. 13 show that the relative story rotation in Model A is more than a single frame in 15th story to 20th story of building height. It shows inappropriate effects of core wall in Model A. Considering of relative stories rotation in Model A and C shows that closed section core in the last story has significant effects on reducing inappropriate results of core in Model A. Thus, ratio of the last story rotation in Model C to Model A is approximately zero. It is revealed that the closed section core in the last story of Model B reduces relative story rotation at the last square of structure height by about 10–74 %. It showed that closed core section has significant effects at the last quarter of structure height.

According to the obtained results in Fig. 12, the bimoment in open core is negative at 15th story level of building and it is similar to wall-frame structures. Furthermore, the core had significant effect on torsion strength of structure at 13th story level and lower levels. In addition, it is clearly

**Fig. 8** **a** Corner positions of core, **b** total stress at corner of core in level of base for model A (kg/cm<sup>2</sup>)

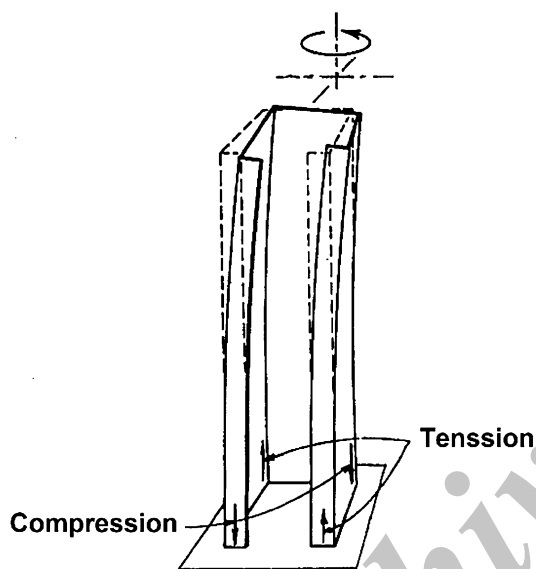
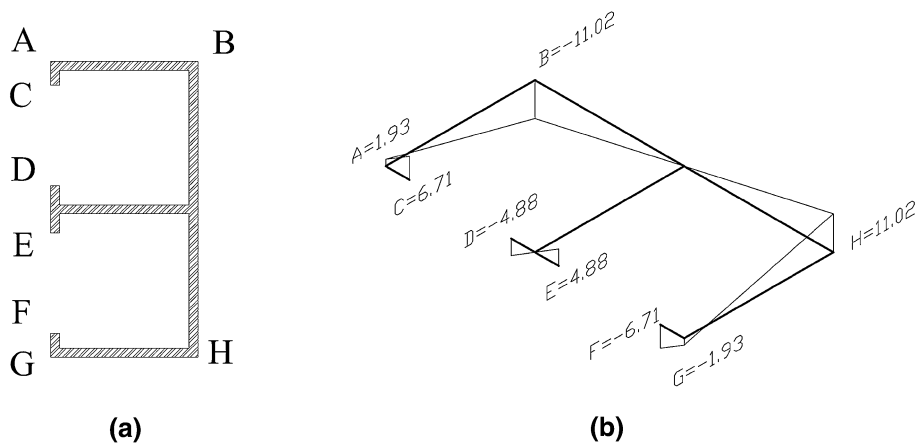
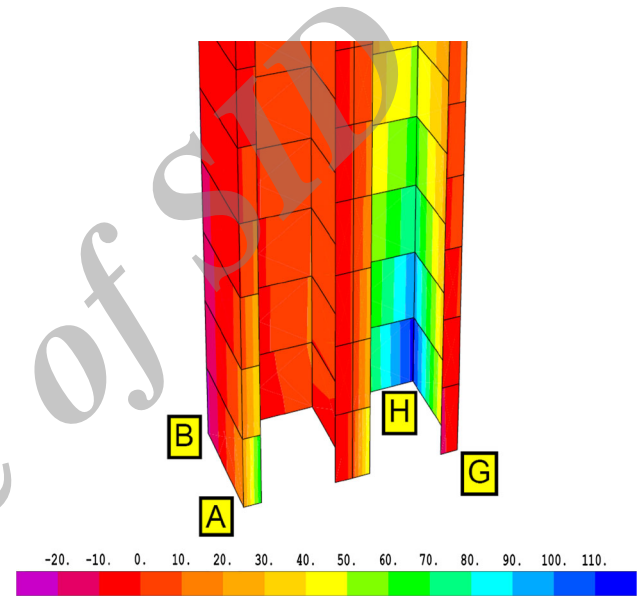

**Fig. 9** Torsion causes axial stress

illustrated that bimoment has negative values in quarter of top of building.

Consideration of the core stress

Figures 14 and 15 illustrate that core system in the last story of Model C has no significant effects on reducing the maximum and average of warping stresses in lower stories. Additional wall in the last story increases maximum warping stress and average of warping stress 2.3 and 2.22 times more than Model A in 17th story of building, respectively. According to the achieved results in Figs. 14 and 15, comparison of warping stresses at the base level between Model B and Model D showed that existence of closed section core at top of models reduces warping stress by about 3.28 % on average. Furthermore, comparison of



**Fig. 10** Maximum axial stress in core wall system in the base level

Model B and Model D at level of 17th story showed that average of warping stress increased to about 57.8 %. Obtained results for all walls in Model B showed that link beams in semi-open core wall system reduce maximum stress by about 40.21 and 39.81 % on average. In addition, based on achieved results in the present study, existence of closed core wall at top stories increases the total stresses in top stories, but it is not effective on stress values of lower stories. Therefore, addition of walls in the last story of core increases warping stress values at top of core to about 1.6–2 times more than models without additional walls in the last story of building.

Consideration of structure rotation

Consideration of stories rotation in all models in Figs. 16 and 17 revealed that link beams have the highest effect on

**Table 3** Calculations of  $\omega$ ,  $I_\omega$ ,  $J$  and  $\alpha$

Calculation of sectorial coordinate of the core

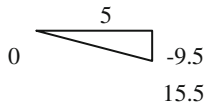
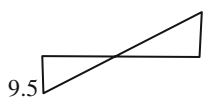
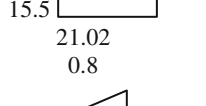
$\omega$   	$\int \omega^2 r dA$ $\frac{1}{3}abl = \frac{1}{3} \times -9.5 \times -9.5 \times 5 \times 0.3 = 45.125 \text{ m}^6$ $0.3\left(\frac{1}{3} \times -9.5 \times -9.5 \times 1.9 + \frac{1}{3} \times 15.5 \times 5.5 \times 3.1\right) = 91.625 \text{ m}^6$ $\frac{0.8}{6}(2 \times 15.5 \times 15.5 + 15.5 \times 21.02 + 21.02 \times 15.5 + 2 \times 21.02 \times 21.02) \times 0.3 = 80.632 \text{ m}^6$ $\frac{1}{3}abl = \frac{1}{3} \times 0.8 \times 5.52 \times 5.52 \times 0.3 = 2.437 \text{ m}^6$ $\text{Sum} = 0.5I_\omega = 219.82 \text{ m}^6$
---	--

Calculation of  $I_\omega$ ,  $J$  and  $\alpha$

$I_\omega = 2 \times I_\omega = 439.64 \text{ m}^6$

$J = \frac{1}{3} \sum_1^n bt^3 = \frac{1}{3} (5 + 5 + 5 + 10 + 0.8 + 0.8 + 1.6) \times 0.3^3 = 0.2538 \text{ m}^4$

$E = 254,929 \text{ kg/cm}^2$

$G = \frac{E}{2(1+\nu)} = \frac{254929}{2(1+0.2)} = 106220.41 \frac{\text{Kg}}{\text{cm}^2}$

$\alpha = \sqrt{\frac{GJ}{EI_\omega}} = \sqrt{\frac{106220.41 \times 0.2538}{254929 \times 439.64}} = 0.0155092$

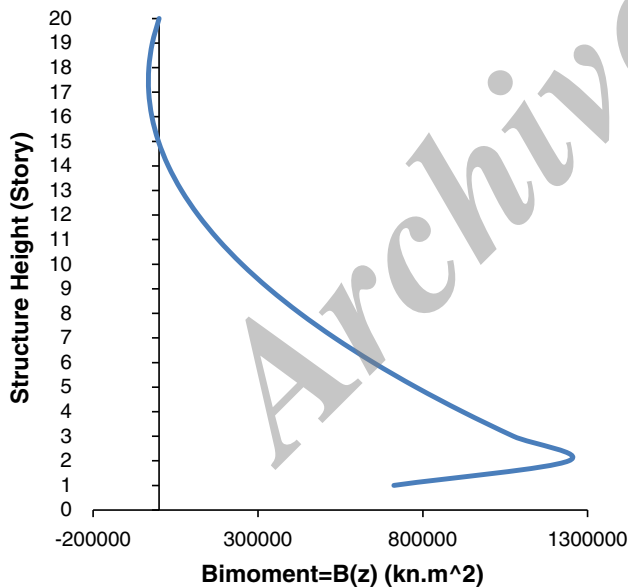

**Fig. 11** Bimoment diagram (B(z)) over the structure height for model Type A

decreasing the story rotation, as link beams decrease stories rotation by 35–53 % in Model A.

Achieved results in Figure 17 showed that closed section core system in the last story has no significant effect on reducing the stories rotation in Model D toward B, also

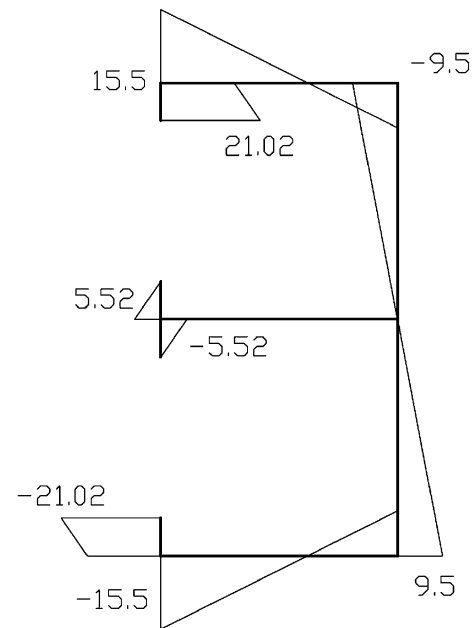

**Fig. 12** Sectorial coordinate of the core in Model A

closed core system in Model C has no significant effect on 14th story and lower levels of it, since closed wall system decreased story rotation by about 10–20 %, in 15th story



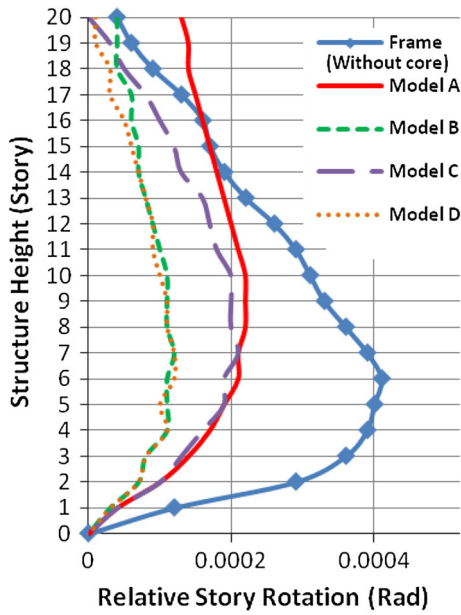

Fig. 13 Relative story rotation in all models

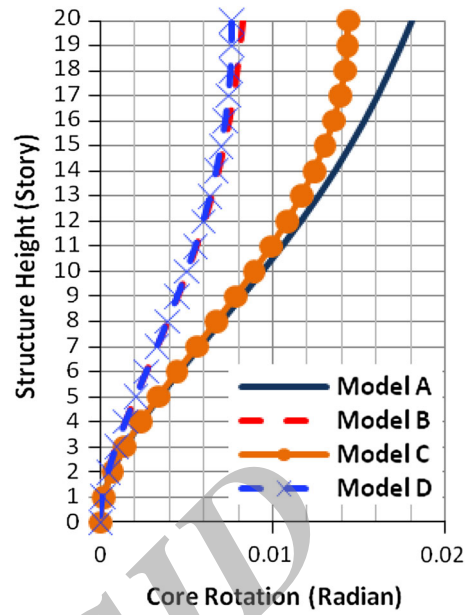

Fig. 16 Core rotation over the models' height

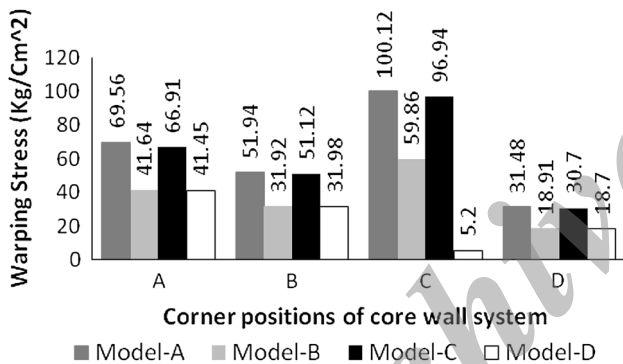

Fig. 14 Comparison of core warping stresses at four positions of core in level of base

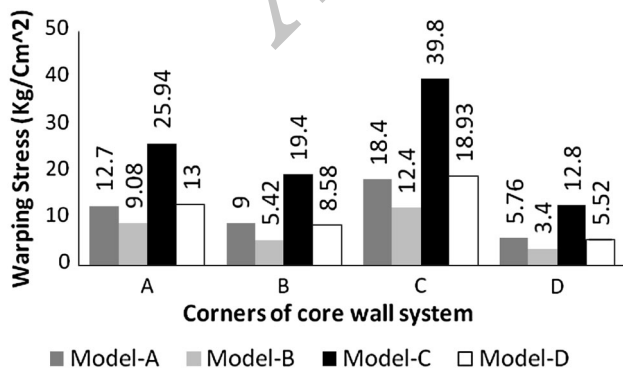

Fig. 15 Comparison of core warping stresses at four positions of core in 17th story level

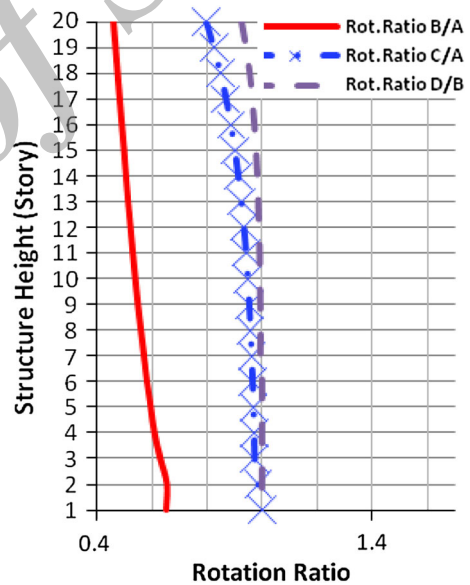

Fig. 17 Ratio of models' core rotation

level and 20th story level, respectively. Obtained analytical results showed that closed core system in the last story has no special effects on 75 % of structure height, but it may reduce stories rotation at the last quarter of structure by about 10–20 %.

Consideration of stories drift

Figures 18 and 19 show the obtained drifts of all models. According to the achieved results, it was revealed that link



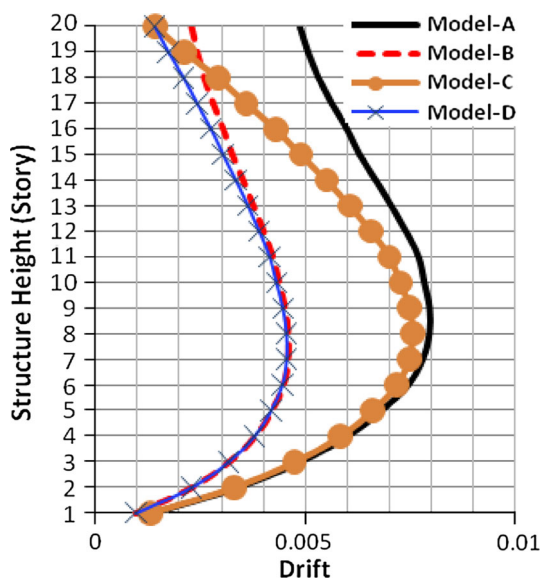

Fig. 18 Comparison of drift of models

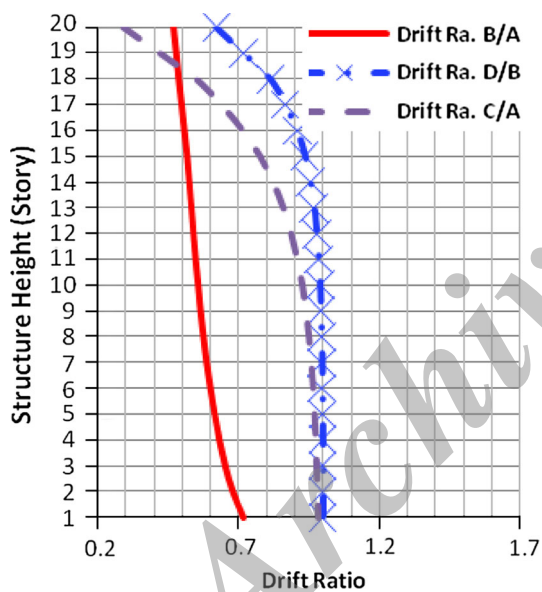

Fig. 19 Models' drift ratio

beams in Model B have significant effect on reducing the stories drift than the Model A. Link beams decreased drift by 38 % at the lower levels of building and 52 % at the top levels. Evaluation of drifts in Model D toward Model B indicated that closed section core system in the last story of Model D has no significant effect on 16th story drift and lower of this level, but the closed section core can decrease the stories drift by about 10–38 % in a quarter of structure height. Comparison of drift in Model C and Model A

showed that closed core system in the last story has no effect on 11th story level and lower levels, but closed core system decreases drifts by about 10 % at 11th story and 70 % in the last story of building. Furthermore, results showed that closed core system in the last story has 10 % effect on decreasing of drift of lower stories but closed core system has significant effect on stories drift of the last quarter of building height.

Consideration of beams shear

According to Fig. 2, lateral load rotates core wall system. One part of core wall rotation resistance is torque resistance and the other is warping resistance. When warping occurs in the core wall system, it causes bimoments in parallel shear wall in the core wall system. If one or two parallel walls are the same as coupled shear walls, bimoments affect coupled shear walls and deform each part of shear wall. Figure 20 shows the internal shear wall forces and three types of coupled wall deformations.

Type (1) is rotation of the wall cross due to bending (Fig. 20a). Its deformation occurs under the action of a bending moment (Fig. 20a);  $\delta_1$  is the relative vertical displacement given by Eq. 3:

$$\delta_1 = (0.5b + d_1) \frac{dg}{dz} + (0.5b + d_2) \frac{dy}{dz} = \sum \left( \frac{dy}{dz} \right) \quad (3)$$

In Eq. 2,  $\frac{dy}{dz}$  is the slope of the centric of areas of the walls at level  $z$  due to the combined bending actions. Type 2 of shear wall deflection is bending and shear deformation of connected beams under the action of the shear flow (Fig. 20b). The vertical displacement  $\delta_2$  is given by Eq. 4:

$$\delta_2 = -z \left( \frac{qdz}{3 \left( \sum \frac{I_b}{h} \right) dz} \right) (0.5b)^3 \quad (4)$$

Wall deformations in Type 3 are governed by the axial deformations in line with the axial force  $N$ .  $\delta_3$  given by Eq. 5:

$$\delta_3 = - \left( \frac{1}{E} \right) \left( \frac{1}{A_1} + \frac{1}{A_2} \right) \int_0^z (N) dz \quad (5)$$

Figures 21 and 22 show a relative displacements at positions C and D in Fig. 8a of walls at all stories level due to warping effects. Figure 21 shows that closed section core system in the last story decreases relative displacement between positions C and D by about 10–85 % for model C than Model A in half level of structure to top level of it.

Comparison between Model D and Model B showed that closed core section in the last story decreases relative

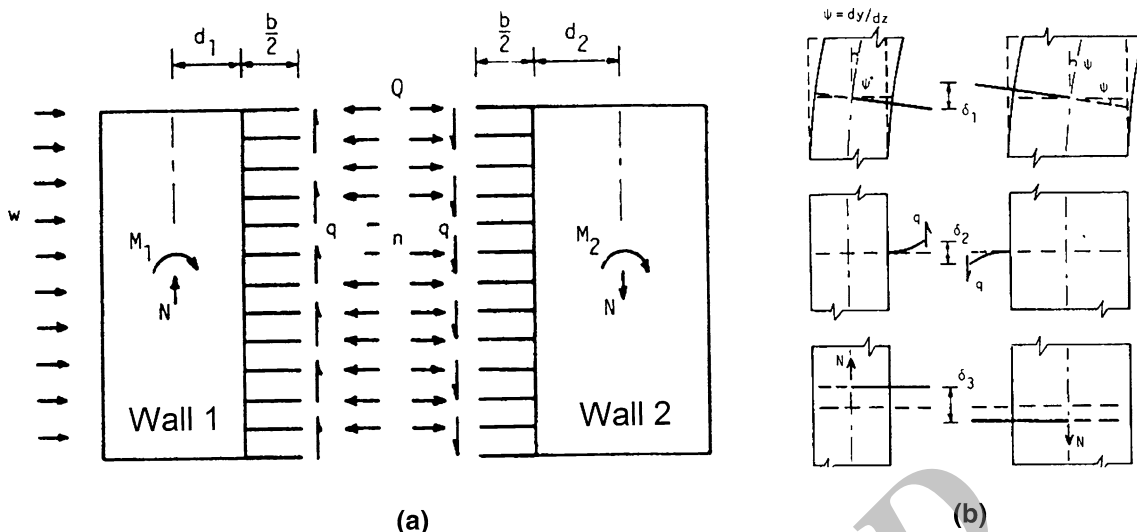

Fig. 20 a Internal force of link beams and walls, b parallel walls relative displacements

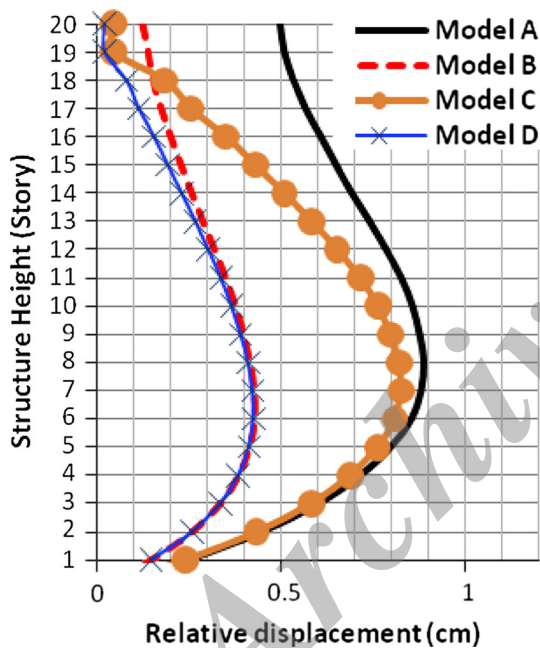

Fig. 21 Relative displacement between shear walls generated by warping

displacement between position C and position D by about 10 % at level of 10th story and about 85 % at level of 20th stories; based on previous results, it is found that last closed section core wall system has significant effects on quarter of top of structures to about 80 %. According to the obtained above results, it can be expected that link beam shear force in Model D has lower value in comparison to Model B at the top quarter level of building. Figures 23 and 24 illustrate that in the last quarter of top of Model D, shear forces in link beams are about 10 % in 14th story and 90 % in 20th story lower than Model B. In addition, closed

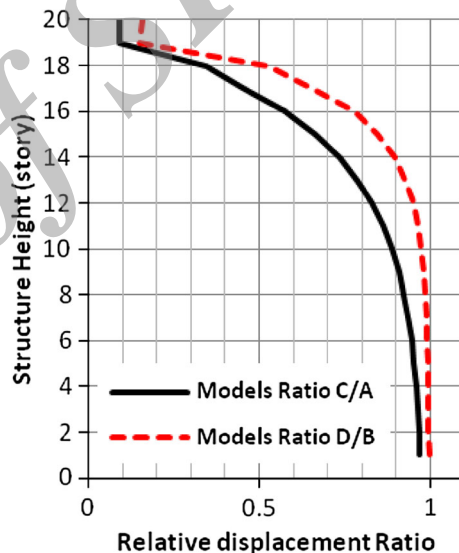

Fig. 22 Relative displacement ratio

section core wall system in the last story increases link beams' shear force by about 60 % on the quarter of building height. Considering of link beam shear force showed that closed section core wall system in the last story decreases shear beam forces by about 10–90 % at the last quarter of structure height.

Consideration of base shear

Consideration of the first period of structures in Fig. 25 revealed that closed core wall system in the last story decreases the first period of structure by about 7.1 % in Model A and 1.7 % in Model B. To consider the closed

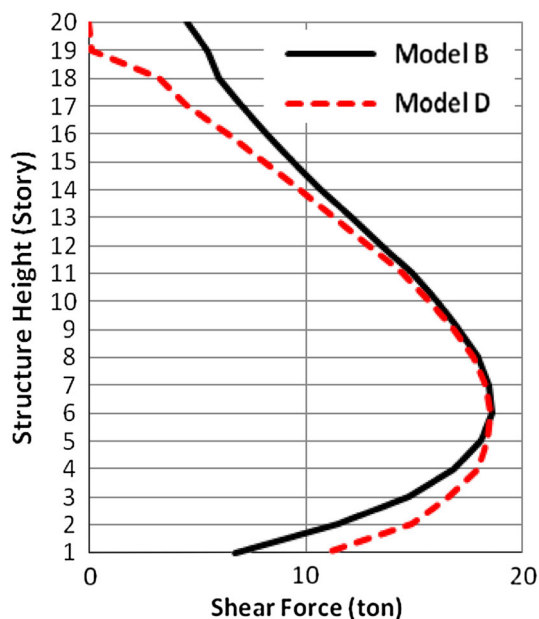

Fig. 23 Link beam shear forces generated by warping

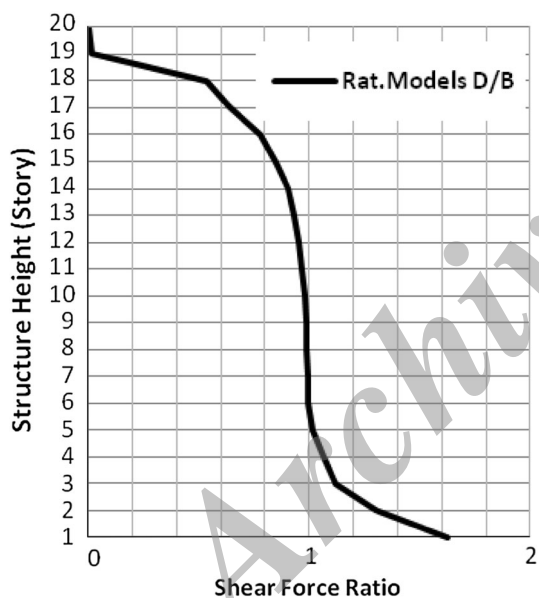

Fig. 24 Ratio of link beam shear forces

core wall system effects in the last story on base shear, ratio of base shear to structure weight ( $V/W$ ) is calculated by UBC97 and Iranian Standard No. 2800 design spectra (International Council of Building Officials 1997; Building and Housing Research Center 2007). Equation 6 is presented by Iranian Standard No. 2800, which is used to calculate  $\frac{V}{W}$ .

$$\frac{V}{W} = \frac{ABI}{R} \tag{6}$$

Parameters in Eq. 6:  $V$  is the base shear,  $W$  the building weight,  $A$  the PGA,  $I$  the important factor,  $B$  the spectral acceleration that is identified by the first period of structures and  $R$  is the ductility factor. In Fig. 26, design spectra are presented for soils with shear velocity between 175 and 375 m/s. In UBC97, near fault spectrum is assigned to a high seismic activity in regions with less than 2 km away from active fault while Iranian Standard spectra considers for regions with high seismic activity. Comparison of results showed that closed section core system in the last story has no significant effect on base shear value. The reason of this phenomenon is related to the tall building period. Tall buildings have long period ( $T > 4.5$  s) while design spectra do not have variation in these ranges of periods. Therefore, closed section core system in the last story has no significant effects on base shear reduction of the models (Fig. 27).

### Conclusion

Increasing tall buildings in urban population caused development of tall building structures. In the present study, the effects of section closing of cores in the last story were investigated by using a 20 stories building under the effect of uniform wind load. The obtained analytical results have summarized which include:

1. Closing of core section in the last story has significant effects on reducing of inappropriate effects of negative bimoment on the last quarter of structure height, since it reduced relative story rotation by about 100 % in open section cores and about 10–74 % in semi-open section cores on the last quarter of building height.
2. According to the pervious results, additional shear walls to close last story core section have not significant effects on core stresses and it sometimes increases axial stress in core by about two times.
3. Consideration of closed section core effects on tall building structures showed that closing of section in the last story has significant effects on reducing structure drifts, as it reduces story drift by about 10–70 % in open section core and 10–38 % in semi-open core section on the last quarter of structure height.
4. One of the useful effects of closed section core in the last story is related to reduction of beams shear by about 10–90 % on the last quarter of structure height.
5. Consideration of base shear in the proposed models showed that existence of closed section core in the last story has no significant effect on decreasing of base shear in the proposed models. According to the obtained results, closed section core in the last story

Fig. 25 Mode shapes period

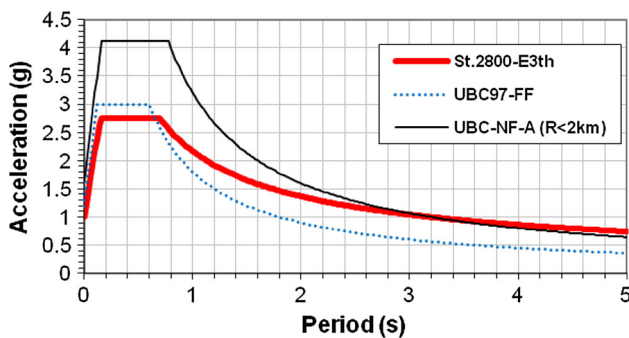
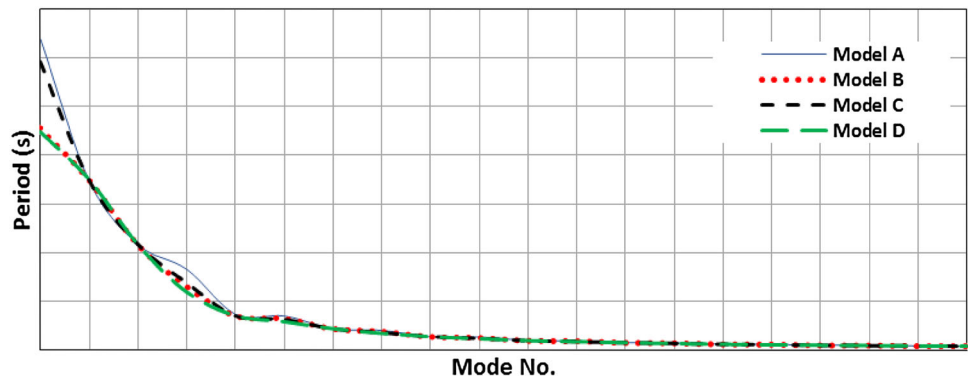

Fig. 26 Standard No. 2800, UBC97 near fault, UBC97 far fault spectra

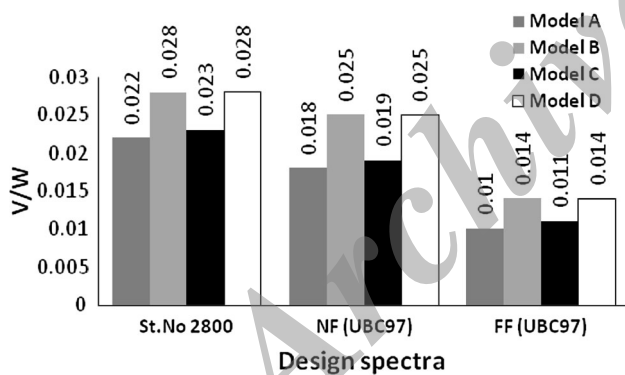

Fig. 27 Base shear to structure weight ratio generated by Standard No. 2800, UBC97 near fault ( $R < 2$  km) and UBC97 far fault design spectra

improved the behavior of the last quarter of structure height, since closing of core section in the last story has no significant effect on reducing base shear in near and far field of active faults.

**Open Access** This article is distributed under the terms of the Creative Commons Attribution License which permits any use, distribution, and reproduction in any medium, provided the original author(s) and the source are credited.

**References**

Building and Housing Research Center (2007) Iranian Code of Practice for Seismic Resistant Design of Buildings [Standard No. 2800, 3th Edition], Tehran, Iran

Emsen E, Turkozer CD, Aksogan O, Resatoglu R, Bikçe M (2009) Non-planar coupled shear walls with stiffening beams. Acad J Sci Res Essay 4(4):328–345

International Council of Building Officials (1997) Uniform Building Code 1997 [UBC97], Washington, USA

Mendis Priyan (2001) Warping analysis of concrete cores. Struct Des Tall Build 10:43–52

Stafford Smith B, Coull A (1991) Tall building structures: analysis and design. Wiley, New York

Swaddiwudhipong S, Soelarno Sidji S, Lee S-L (2002) The effects of axial deformation and axial force on vibration characteristics of tall building. Struct Des Tall Build 11:309–328

Zalka KA (2009) A simple method for the deflection analysis of tall wall-frame building structures under horizontal load. Des Tall Build 18:291–311