

## Improving the Power Quality of Photovoltaic System with Fuzzy Controller

Milad Pourhasan

Department of Electrical Engineering ,University of Mohagheh Ardabili, Ardabil, Iran

milad.pur1996@gmail.com

Received: June 2023

Accepted: August 2023

### Abstract

Today, due to the pollution of fossil fuels and the limitation of fossil energies, and the increase in demand, the need for alternative and clean energy is felt more than before. One of the sources of free energy supply in this regard is solar energy, which has received attention in the last few years. With the increasing use of photovoltaic systems, the needs based on technical issues and exploitation of this energy has increased. Since the electrical power supplied by solar systems depends on the insulation temperature and the amount of radiation. Solar cells have an optimal working point that is able to receive the maximum and improve the quality of the power that is needed to obtain the maximum power from the photovoltaic system. The system needs a tracking controller with maximum power. A fuzzy controller is used to control the maximum power of photovoltaic systems. Based on fuzzy sets and fuzzy algorithms, fuzzy theory prepares a general method of expressing language rules so that it is possible to process them quickly. In this research, a photovoltaic system based on fuzzy control has been designed and implemented to improve the quality of power from solar cells in the MATLAB software environment.

**Keywords:** Photovoltaic Systems, Power Quality Improvement, Fuzzy controller, DC/DC converter.

### 1-Introduction

Solar energy is one of the sources in which renewable sources have been used significantly. These sources are formed in low and medium voltage, which is among a set of renewable energy sources such as wind and energy storage systems of this type [1-3]. Today, solar energy is used in many cases, such as battery charging, water pumping, and home energy supply. No need for maintenance and repair as well as no pollution is one of the advantages of these resources. But in some practical cases to feed the load, they need a dc/dc or dc/ac converter whose output is the input of the dc/dc converter. By using the dc/dc converter and tracking the maximum point, it is possible to absorb the maximum possible power from the inputs [4-5]. Then this power is sent to the inverter at its output so that this section can provide the desired form of energy for the consumption of loads by changing the generated DC power to AC power with the appropriate range and frequency. The inverter of this circuit is switched by the PWM method in order to provide the possibility of adjusting the output voltage against average load changes, the use of controllers is distributed in the network by providing higher quality power [6-8]. Due to the use of new technology of renewable energy such as wind and sun, management and optimal and safe use of the network has become one of the research priorities of researchers in this field. Predicting the behavior of these resources and their optimal use will

increase the efficiency of the system [9-10]. In ref [11], they performed a new method to improve the efficiency of the solar system and maximize energy harvesting from photovoltaic modules by using the maximum power point. One of the advantages used in the proposed method is the fast and accurate implementation of the algorithm in the system. It was a design. In the reviews, several experiments were studied and favorable results were obtained. In ref [12], he presented an article under the title of obtaining the maximum power from a hybrid system including photovoltaic, wind and fuel cell. The maximum power point was used in all combined systems. Several distinct controllers were assigned for each system. In reference [13], they investigated the maximum transmission power using genetic and fuzzy methods. In reference [14], they investigated the types of intelligent methods (IMs) used in tracking the maximum power point and their implementation in programming. In ref [15], they investigated the maximum power received from the photovoltaic system. To get the maximum power from photovoltaic, usually, the photovoltaic power system needs a series of controllers to get the maximum power. In ref [16], they presented an article titled a combination of firefly algorithm and P&O Algorithm. The firefly algorithm had faster accuracy and convergence than P&O. The main advantage of the combination of these two methods was in obtaining the maximum power from the effective photovoltaic system and favorable results were obtained from the test of the desired system.

In reference [17], they presented an analysis between four algorithms for maximum power point tracking (MPPT) with Boost DC/DC converter. In today's electricity grid [18], the use of these sources has increased due to the limited power. By using these resources, it is possible to use these resources in distribution networks [19-24] in buses that have a demand response.

When a direct connection is established between the load and the source, the output of the photovoltaic module rarely has the maximum power and the working point is not optimal. To solve this problem, the phase controller with a DC/DC converter between the load and the source will be considered. It is used to compensate for the output voltage of the solar panel to keep the voltage constant at a value that maximizes the output power. The maximum power point phase controller measures the voltage and current at the output of the solar panel, then the power at the output of the panel. The maximum power point tracker follows the new modified maximum power point in the curve corresponding to each temperature or different radiation intensity that occurs. In this research, a photovoltaic system based on phase control with the maximum point and improvement of power quality from solar cells will be designed and implemented in the MATLAB software environment and the results obtained will be compared with other works done.

## **2- Photovoltaic systems connected to the grid**

In order to strengthen the national power grid and prevent the electrical pressure on power plants during the day, the use of photovoltaic systems connected to the national power grid in a centralized or decentralized manner is one of the solutions to this problem. The power produced in solar panels is passed through the buck-boost converter (Figure 1) and is delivered to the grid by a DC-to-AC inverter [25-26]. [Today, photovoltaic systems connected to the grid in many countries of the world are in small units from 1 kW to 5 kW Photovoltaic power plants have been installed on the roofs of residential houses and in larger units.

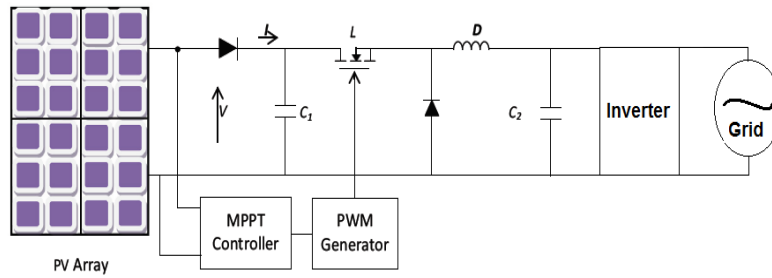


Figure1- Photovoltaic systems connected to the grid

The solar cell can be modeled as a parallel current source with a diode as shown in figure (2). When there is no light to generate current, the solar cell acts as a diode.

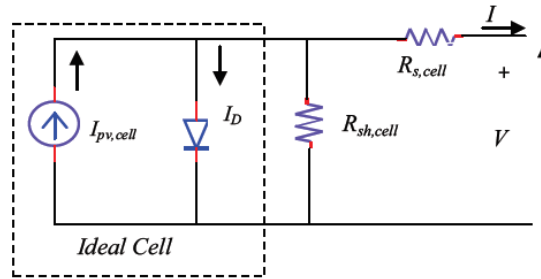


Figure 2- Equivalent circuit of a solar cell

From the point of view of semiconductor physics, the bridge is essentially a large P-N junction diode. An ideal solar cell may be modeled with a current source parallel to a diode, which is mathematically described with the I-V characteristic as follows:

$$I = I_L - I_0 \left( e^{\frac{q(V+I.R_S)}{nkT}} - 1 \right) - \frac{V + I.R_S}{R_{SH}} \quad (1)$$

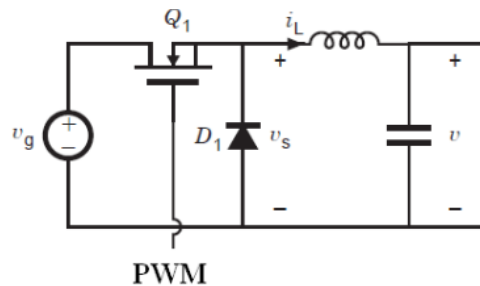
In this relation, RS and RSH are the series and parallel resistances respectively, I\_L is the radiation current, I\_0 is the diode current, k is Boltzmann's constant, q is the electric charge of an electron, T is the temperature of the cell, and n is the ideal coefficient of the diode and the nominal thermal voltage of the cell. No solar cell is ideal in practice, and series and parallel resistors are also added to the model. The solar radiation flow I\_L is also defined according to the following equation:

$$I_L = (I_{pv,n} + k_1 \Delta T) \frac{G}{G_n} \quad (2)$$

I\_L(Pv,n) is the current produced by the light signal of the photovoltaic cell and G is the radiation on the device and G\_n is the nominal radiation.

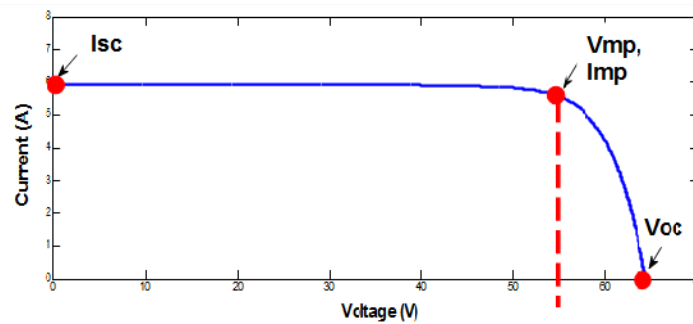
$$I_0 = \frac{I_{sc,n} + k_1 \Delta T}{\exp\left(\frac{V_{oc} + k_1 \Delta T}{avt}\right) - 1} \quad (3)$$

Figure (3) shows the buck converter of a DC to DC step-down converter. The operation of the converter is relatively simple, with an inductor, diode transistors that control the current of the inductor.

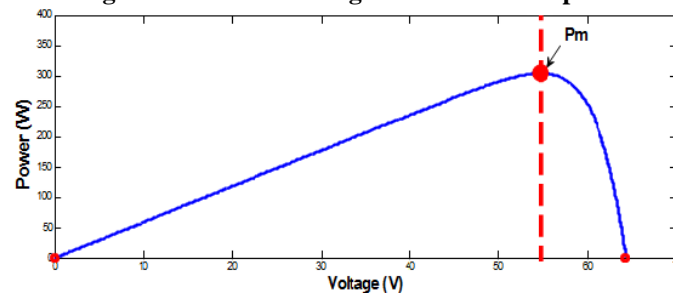


**Figure 3- Buck converter is a DC to DC step-down converter**

The current-voltage curve of a sample solar panel is shown in Figure (4). As it can be seen, for each point on the curve, there is a voltage and a current corresponding to it, which is not necessarily the maximum current or maximum voltage. For example, at point E, the voltage is max, but the current is zero, or for point B, the current is max, but the corresponding voltage is not max. For optimal use of the energy produced by the photovoltaic panel, a point with the highest current and voltage should be selected. Obtaining the optimal point is done by the maximum power follower. Figure (5) shows the output power in terms of voltage for a photovoltaic panel. By comparing the figure, it can be seen that the maximum power is obtained at point C, which is the optimal point. The maximum power follower is actually a high-efficiency DC-DC converter that adjusts its output voltage to an optimal value to obtain maximum power. The maximum power tracker can play a very effective role on cloudy, cold days or in the mode where the battery is used. Of course, in choosing the maximum power follower, the cost and complexity should be considered. In cases where the photovoltaic units are equipped with the maximum power follower, the output of the photovoltaic system is directly related to the converter and the maximum power follower.



**Figure 4- Current-voltage curve of a solar panel**



**Figure 5- power-voltage curve of a solar panel**

### 3- Fuzzy logic controller

Creation of fuzzy logic membership functions, relational between input and output variables, and the minimum number of inputs for fuzzy logic inference engine to be selected (usually error and amount of error changes). Membership function

It determines the values of the input and output conditions used in the rules. The selection of appropriate membership functions is sensitive because the output of fuzzy systems can be changed by changing the parameters of the membership function. A membership function can be defined as a curve that defines each point in the input space for a membership value. According to the figure, the components of the membership function can be defined as follows [27-28] (Figure 6)

- 1- The height or range is usually normalized to one.
- 2- The width or range depends on the function.
- 3- If the shoulder part is an external function, it keeps the height at the maximum.
- 4- Center point (the center of the shape of the membership function)

5- The overlap of Z&P and N&Z is generally around 50% of the range, but it can be less.

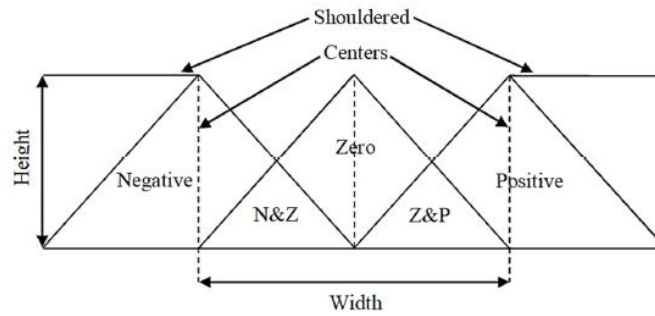


Figure 6- membership functions

4- Designing a controller based on fuzzy logic

Fuzzy control for tracking the maximum point of power generation and invert switching is the main point in designing a control method for photovoltaic connected to the grid. In general, the controller system consists of three basic modules that pursue the following three goals:

- A. Converter control - DC to DC for operation at the maximum power point in any weather condition
- B. Maintaining the bus voltage - DC inverter at the desired value
- C. Power delivery to the network at a unit power factor that requires the same phase of current and output voltage. -

The amount of solar radiation and the temperature of the photovoltaic cell are considered as two weather variables.

In this section, a fuzzy controller with two inputs (power and voltage) and one output (one output unit) is designed, Figure (7), (8), and (9). The main advantage of the fuzzy controller is that it does not need accurate information about the system. Fuzzy model is used in the fuzzy controller and if-then rules are used for the inference engine.

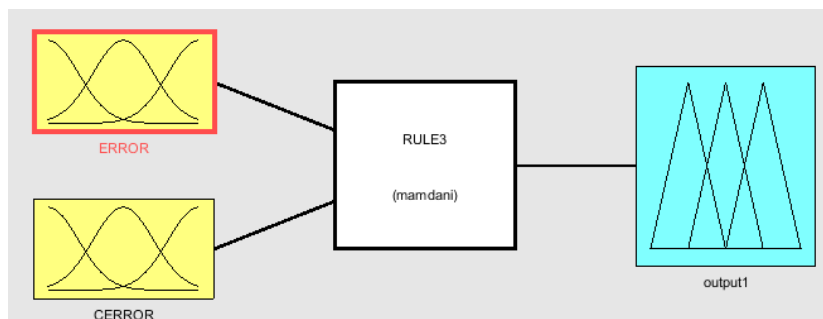


Figure 7-Fuzzy logic controller with two inputs and one output

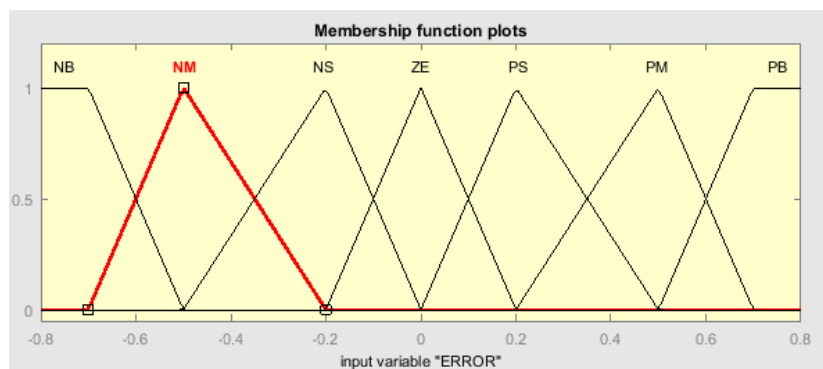


Figure 8- Input membership function for power

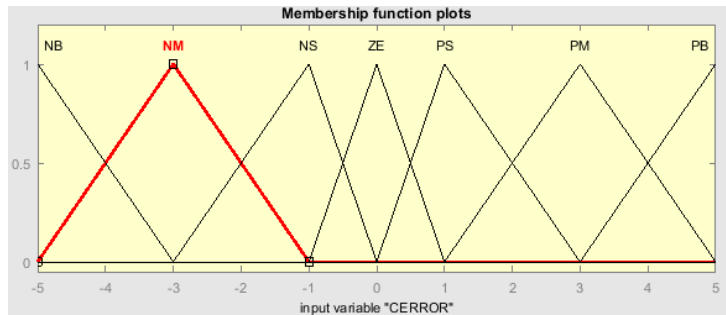


Figure 9- input membership function for voltage

The appropriate domain for each period and the number of membership functions can be defined based on experiments and system configuration. Figure (10) shows the output membership function for the controller.

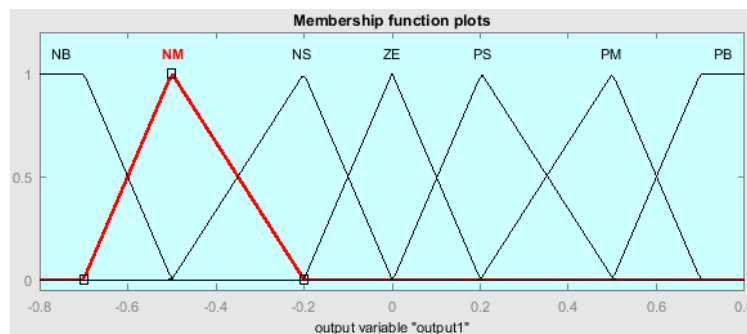


Figure 10- Output membership function

Table (1) shows the phase controller designed for the photovoltaic system based on the law.

Table 1- Rule base for fuzzy controller [29]

	NB	NM	NS	ZE	PS	PM	PB
NB	ZE	ZE	ZE	NB	NB	NB	NB
NM	ZE	ZE	ZE	NM	NM	NM	NM
NS	NS	ZE	ZE	NS	NS	NS	NS
ZE	NM	NS	ZE	ZE	ZE	PS	PM
PS	PM	PS	PS	PS	ZE	ZE	PS
PM	PM	PM	PM	PM	ZE	ZE	ZE
PB	PB	PB	PB	PB	ZE	ZE	ZE

### 5- The studied system

For testing, the single-line diagram of the studied system is shown in Figure (11). The information on this model is given in Table (2).

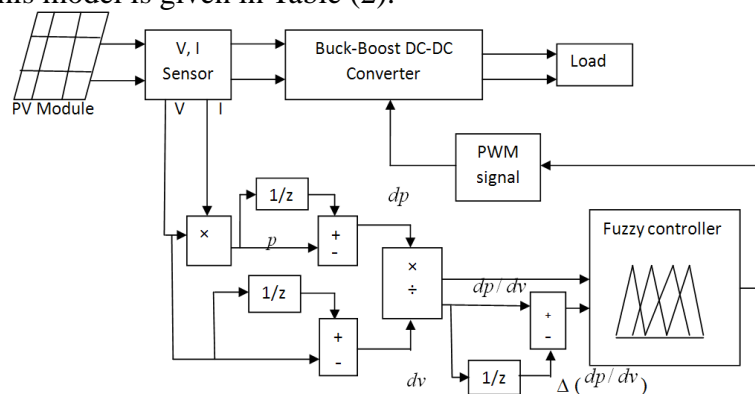


Figure 11- The studied system

Table 2- information of the studied system

photovoltaic system power	200W
maximum voltage	27.61V
maximum current	7.61A
open circuit voltage	33.64V
short circuit current	8.21A
flow coefficient on temperature	$K_i = 0.003$
coefficient of voltage on temperature	$K_v = -0.123$
Boltzmann constant	$1.6 \times 10^{-19}$
number of cells in the series	$N_s = 54$

### 6- Simulation of the studied system

The Simulink model of the photovoltaic system is shown in Figure (12) and the phase controller and buck converter are shown.

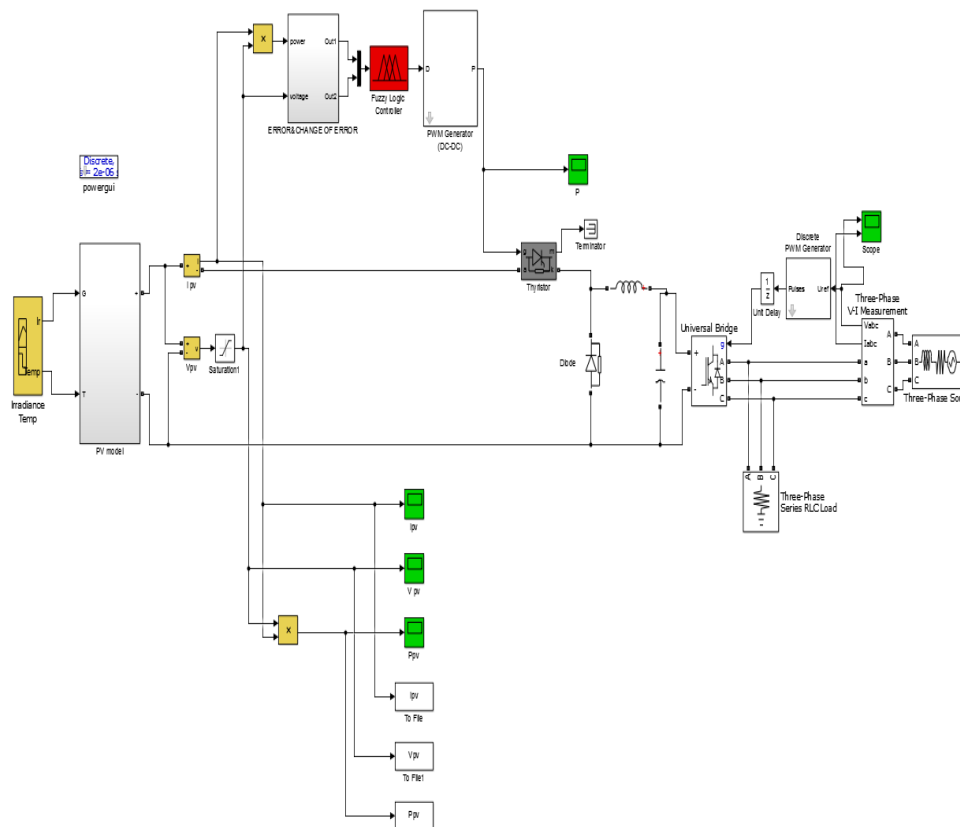


Figure 12- Proposed fuzzy controller model

### 7- The results of the simulation

In this section, with the help of software, the implementation and execution of the designed model, which was defined in the previous chapter, is discussed. In this section, the aim is to investigate the variable factor of solar radiation intensity and temperature stability on the output power and current from the solar panel. The temperature value is 25 degrees Celsius and the radiant intensity is considered to be from zero to 1000 W/m<sup>2</sup>, which are shown in figure (13).

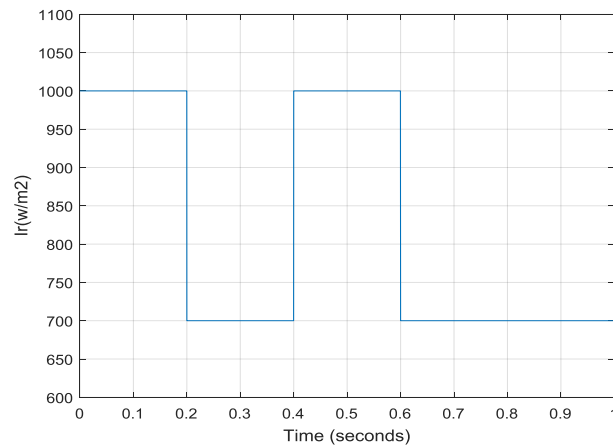


Figure 13- Intensity of solar radiation

According to the governing relations and the simulation performed, one of the basic parameters in the output power as well as the output current of a solar cell is the intensity of the sun's radiation, which in the diagrams of figure (14) and (15) with the variable intensity of different radiations, the amount of power The output and the output current can be seen. As it can be seen, with the increase in the intensity of solar radiation, the amount of current increases and the resulting power also increases, and at the final radiation intensity, which is 1000 W/m<sup>2</sup>, the amount of current reaches the maximum amount and the resulting power. From the system also reaches the maximum value. Figure (16) shows the amount of error and changes in power and voltage based on the phase controller obtained by the Mamdani method, which works based on the changes in power and output voltage of the source.

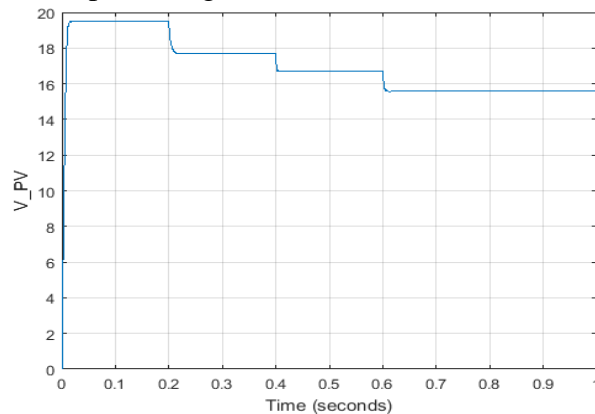


Figure 14- Photovoltaic voltage value

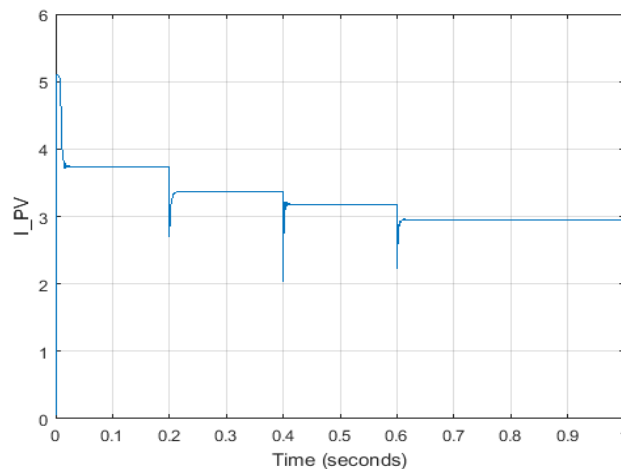


Figure 15- Photovoltaic current value



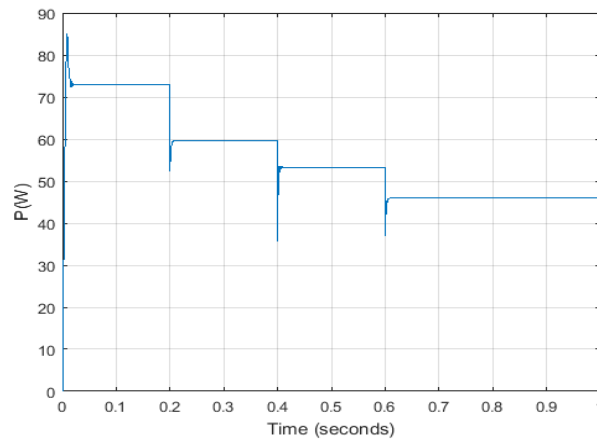


Figure 16- Output power from the photovoltaic system

As it is known, after collecting the results of the rules, it is performed and obtained on the output membership function, i.e. the maximum power. The maximum power point detector system measures the maximum point of current and voltage with fuzzy control and then gives these values to the fuzzy logic to obtain the maximum output. The meaning of the method of inference in a fuzzy inference system is how the base of an input signal, the output value is determined. The fuzzy logic output is applied to the input of the boost and buck converter and then transferred to the load. In figures (17), (18) and (19) the results are shown based on the fuzzy counter and it can be seen that the results are improved compared to the first scenario.

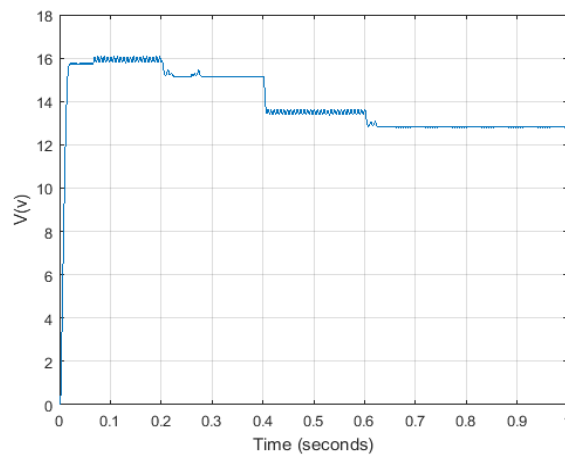


Figure 17-Dual load voltage with fuzzy controller

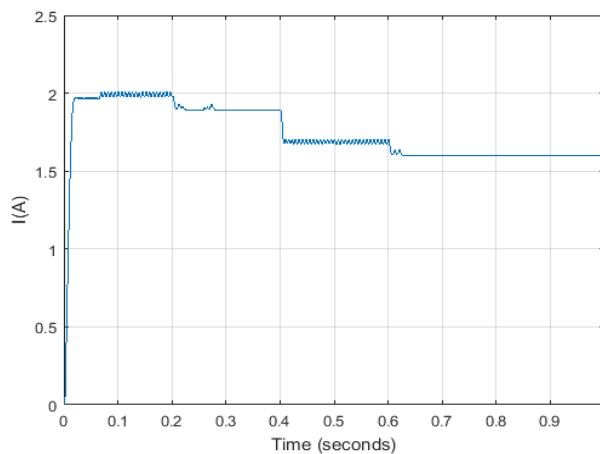


Figure 18- Dual load flow with fuzzy controller

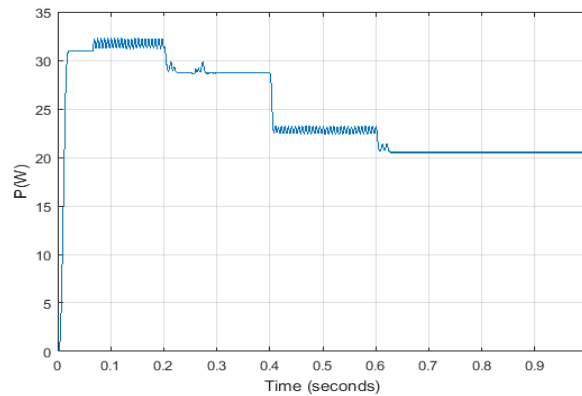


Figure 19- Dual load power with fuzzy controller

## 8-Conclusion

Considering the pollution of fossil fuels and the limited reserves of these fuels, countries are forced to replace these sources of energy with other sources with less pollution, and the best option among them is the use of renewable energies. Therefore, in the current research, the use of solar energy has been analyzed and investigated. In this research, the effect of various environmental factors such as solar radiation intensity and ambient temperature on the output power and output current of the photovoltaic system with the fuzzy controller was investigated. In order to improve the performance of photovoltaic systems, a fuzzy controller was introduced. The fuzzy controller uses the rules and principles of the fuzzy logic language, which is used by separately adjusting the voltage and power as input for the fuzzy adapter for compatibility in the system.

## 9- References

1. Akbari, E., Sheikholeslami, A. R., & Zishan, F. (2023). Participation of Renewable Energy in Providing Demand Response in Presence of Energy Storage. *Renewable Energy Research and Applications*, 4(2), 225-234.
2. Rahman, M. M., Oni, A. O., Gemechu, E., & Kumar, A. (2020). Assessment of energy storage technologies: A review. *Energy Conversion and Management*, 223, 113295.
3. Grisales-Noreña, L. F., Montoya, O. D., Cortés-Caicedo, B., Zishan, F., & Rosero-García, J. (2023). Optimal Power Dispatch of PV Generators in AC Distribution Networks by Considering Solar, Environmental, and Power Demand Conditions from Colombia. *Mathematics*, 11(2), 484.
4. Ram, J. P., Babu, T. S., & Rajasekar, N. (2017). A comprehensive review on solar PV maximum power point tracking techniques. *Renewable and Sustainable Energy Reviews*, 67, 826-847.
5. Tightiz, L., Mansouri, S., Zishan, F., Yoo, J., & Shafaghatian, N. (2022). Maximum Power Point Tracking for Photovoltaic Systems Operating under Partially Shaded Conditions Using SALP Swarm Algorithm. *Energies*, 15(21), 8210.
6. Alayi, R., Zishan, F., Seyednouri, S. R., Kumar, R., Ahmadi, M. H., & Sharifpur, M. (2021). Optimal load frequency control of island microgrids via a PID controller in the presence of wind turbine and PV. *Sustainability*, 13(19), 10728.
7. Alayi, R., Zishan, F., Mohkam, M., Hoseinzadeh, S., Memon, S., & Garcia, D. A. (2021). A sustainable energy distribution configuration for microgrids integrated to the national grid using back-to-back converters in a renewable power system. *Electronics*, 10(15), 1826.
8. Sadeghi, B., Shafaghatian, N., Alayi, R., El Haj Assad, M., Zishan, F., & Hosseinzadeh, H. (2022). Optimization of synchronized frequency and voltage control for a distributed generation system using the Black Widow Optimization algorithm. *Clean Energy*, 6(1), 105-118.
9. Ganjei, N., Zishan, F., Alayi, R., Samadi, H., Jahangiri, M., Kumar, R., & Mohammadian, A. (2022). Designing and sensitivity analysis of an off-grid hybrid wind-solar power plant with diesel generator and battery backup for the rural area in Iran. *Journal of Engineering*, 2022.
10. Zhu, L., Xu, Y., & Pan, Y. (2019). Enabled comparative advantage strategy in China's solar PV development. *Energy Policy*, 133, 110880.

11. Kheldoun, A. B. R. B., Bradai, R., Boukenoui, R., & Mellit, A. (2016). A new Golden Section method-based maximum power point tracking algorithm for photovoltaic systems. *Energy Conversion and Management*, 111, 125-136.
12. Amani, S., Arash, A., Ebrahimian, H., & Zishan, F. (2015). Optimization and Design of Wind and Solar Hybrid System with Battery Storage using Bader PSO Algorithm Considering the Economic Constraints.
13. Messai, A., Mellit, A., Guessoum, A., & Kalogirou, S. A. (2011). Maximum power point tracking using a GA optimized fuzzy logic controller and its FPGA implementation. *Solar energy*, 85(2), 265-277.
14. Chekired, F., Mellit, A., Kalogirou, S. A., & Larbes, C. (2014). Intelligent maximum power point trackers for photovoltaic applications using FPGA chip: A comparative study. *Solar Energy*, 101, 83-99.
15. Hamed, B. M., & El-Moghany, M. S. (2012). Fuzzy controller design using FPGA for photovoltaic maximum power point tracking. *International Journal of Advanced Research in Artificial Intelligence*, 1(3), 14-21.
16. Safarudin, Y. M., Priyadi, A., Purnomo, M. H., & Pujiantara, M. (2015, May). Combining simplified firefly and modified p&o algorithm for maximum power point tracking of photovoltaic system under partial shading condition. In *2015 International Seminar on Intelligent Technology and Its Applications (ISITIA)* (pp. 181-186). IEEE.
17. Salas-Puente, R., Marzal, S., González-Medina, R., Figueres, E., & Garcerá, G. (2017, September). Efficient management strategy of the power converters connected to the DC bus in a hybrid microgrid of Distributed Generation. In *2017 19th European Conference on Power Electronics and Applications (EPE'17 ECCE Europe)* (pp. P-1). IEEE.
18. Zishan, F., Akbari, E., Montoya, O. D., Giral-Ramírez, D. A., & Nivia-Vargas, A. M. (2022). Electricity retail market and accountability-based strategic bidding model with short-term energy storage considering the uncertainty of consumer demand response. *Results in Engineering*, 16, 100679.
19. Panigrahi, R., Mishra, S. K., Srivastava, S. C., Srivastava, A. K., & Schulz, N. N. (2020). Grid integration of small-scale photovoltaic systems in secondary distribution network—A review. *IEEE Transactions on Industry Applications*, 56(3), 3178-3195.
20. Sadeghi, B., Shafaghatian, N., Alayi, R., El Haj Assad, M., Zishan, F., & Hosseinzadeh, H. (2022). Optimization of synchronized frequency and voltage control for a distributed generation system using the Black Widow Optimization algorithm. *Clean Energy*, 6(1), 105-118.
21. Akbari, E., Shafaghatian, N., Zishan, F., Montoya, O. D., & Giral-Ramírez, D. A. (2022). Optimized Two-Level Control of Islanded Microgrids to Reduce Fluctuations. *IEEE Access*, 10, 95824-95838.
22. Zishan, F., Akbari, E., Montoya, O. D., Giral-Ramírez, D. A., & Molina-Cabrera, A. (2022). Efficient PID Control Design for Frequency Regulation in an Independent Microgrid Based on the Hybrid PSO-GSA Algorithm. *Electronics*, 11(23), 3886.
23. Mansouri, S., Zishan, F., Montoya, O. D., Azimzadeh, M., & Giral-Ramírez, D. A. (2023). Using an intelligent method for microgrid generation and operation planning while considering load uncertainty. *Results in Engineering*, 17, 100978.
24. Zishan, F., Mansouri, S., Abdollahpour, F., Grisales-Noreña, L. F., & Montoya, O. D. (2023). Allocation of Renewable Energy Resources in Distribution Systems while Considering the Uncertainty of Wind and Solar Resources via the Multi-Objective Salp Swarm Algorithm. *Energies*, 16(1), 474.
25. Montoya, O. D., Zishan, F., & Giral-Ramírez, D. A. (2022). Recursive Convex Model for Optimal Power Flow Solution in Monopolar DC Networks. *Mathematics*, 10(19), 3649.
26. Yang, B., Li, W., Zhao, Y., & He, X. (2009). Design and analysis of a grid-connected photovoltaic power system. *IEEE transactions on power electronics*, 25(4), 992-1000.
27. Zishan, F., Montoya, O. D., & Giral-Ramírez, D. A. (2023). New Design and Study of the Transient State and Maximum Power Point Tracking of Solid Oxide Fuel Cells Using Fuzzy Control. *Energies*, 16(6), 2572.
28. Hannan, M. A., Ghani, Z. A., Hoque, M. M., Ker, P. J., Hussain, A., & Mohamed, A. (2019). Fuzzy logic inverter controller in photovoltaic applications: Issues and recommendations. *Ieee Access*, 7, 24934-24955.
29. Zishan, F., Tighiz, L., Yoo, J., & Shafaghatian, N. (2023). Sustainability of the Permanent Magnet Synchronous Generator Wind Turbine Control Strategy in On-Grid Operating Modes. *Energies*, 16(10), 4108.