



Gradual pumping through filtration sleeves: An approach for extracting narrow contaminant enclaves in groundwater

Paul Francis Hudak

Department of Geography and the Environment, University of North Texas, Denton, Texas, USA.

GRAPHICAL ABSTRACT

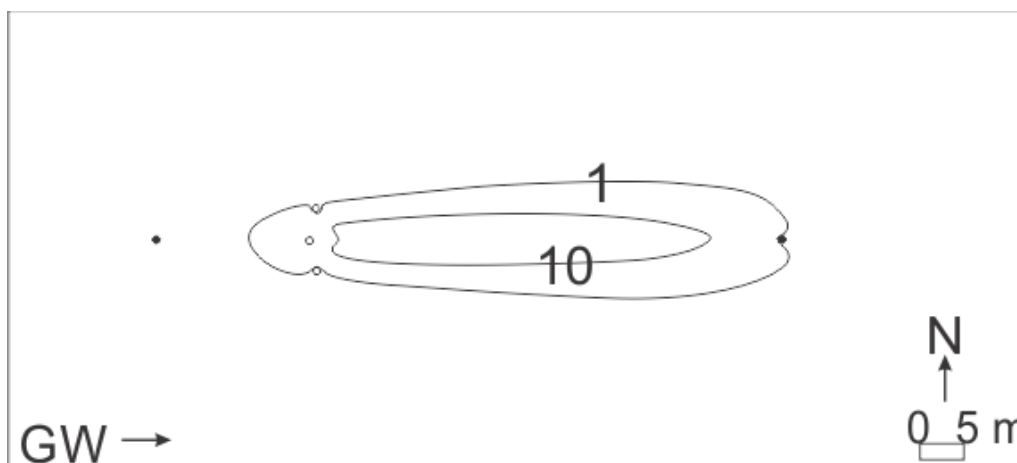

ARTICLE INFO

Article type:

Short Communication

Article history:

Received 15 June 2023

Received in revised form 14 August 2023

Accepted 17 August 2023

Available online 19 August 2023

Keywords:

Lined impoundment

Groundwater

Sleeved extraction well



© The Author(s)

Publisher: Razi University

ABSTRACT

Low-energy extraction wells fitted with filtration sleeves were numerically modeled to assess their capability to extract narrow contaminant plumes in a hypothetical unconfined aquifer beneath a lined landfill. After 2,000 days, the source was shut off and remediation simulations commenced. A sleeved submersible pump extracting 0.4 m³/day in a well near the downgradient edge of the plume, coupled with an upgradient well injecting the same rate, effectively contained and removed the plume. Adding non-pumped filtration wells upgradient of the extraction well marginally improved containment and remediation timeframe. At some sites, low-energy, sleeved extraction wells may be useful for extracting narrow plumes emerging from contemporary landfills.

1. Introduction

Countless landfills worldwide have contaminated groundwater. Older facilities without containment typically release contaminated water to the subsurface. However, leachate can also seep through small holes or tears in lined landfills. Timely source control and remediation can mitigate aquifer contamination. Energy efficiency is an important consideration for potentially costly aquifer cleanup (Caliman *et al.*, 2011). Examples of low-energy remediation alternatives are reactive trenches, non-pumped wells with filtration media, and low-discharge wells. Placed downgradient of contaminant plumes, reactive trenches filter or decompose pollutants without pumping groundwater (Richardson and Nicklow, 2002). However, excavating trenches, filling them with filtration media, and replacing spent media is an expensive operation. Non-pumped wells with replaceable cartridges containing filtration media are less costly and can access greater depths than

trenches (USGS, 1999). But non-pumped wells require close spacing and may be too costly for wide contaminant plumes (Hudak, 2009).

Alternatively, downgradient low-discharge (low-power) wells can remove some (small) contaminant plumes in groundwater. Low-discharge wells produce narrow capture zones, but they are wider than capture zones of non-pumped wells. Removed water can be treated thoroughly at the land surface, and treated water can be re-injected upgradient of a contaminant plume. Small holes in modern landfill liners typically generate narrow plumes (Lee and Jones-Lee, 1994) removable with low-capacity wells.

Additionally, a submersible pump in a low discharge well can be fitted with a permeable sleeve containing filtration media. For example, a 0.20 m-diameter, slotted PVC casing could be centered in a wider hole drilled by hollow-stem auger. Sand would fill the space outside the screened interval, a common practice. After developing the well, a removable pump, fitted with a filtration sleeve, could be lowered down

*Corresponding author Email: hudak@unt.edu

the casing. Periodically, the pump and sleeve would be removed for maintenance and replacement. This study explored the viability of sleeved extraction wells, at low discharge, to extract narrow bodies of contaminated groundwater moving hydraulically downgradient of a hypothetical lined waste storage facility.

2. Material and methods

MT3DMS (Zheng and Wang, 1999) was deployed to simulate moving groundwater and dissolved contaminant in a hypothetical unconfined aquifer (Fig. 1). The governing equation used by MT3DMS, a numerical, block-centered finite-difference model, is:

$$\frac{\partial(\theta C^k)}{\partial t} = \frac{\partial}{\partial x_i} \left(\theta D_{ij} \frac{\partial C^k}{\partial x_j} \right) - \frac{\partial}{\partial x_i} (\theta v_i C^k) + q_s C_s^k + \sum R_n \quad (1)$$

where,

θ = porosity, dimensionless

C^k = dissolved concentration of species k , ML^{-3}

t = time, T

$x_{i,j}$ = distance along respective Cartesian coordinate axis, L

D_{ij} = hydrodynamic dispersion coefficient tensor, L^2T^{-1}

v_i = seepage velocity, LT^{-1}

q_s = volumetric flow rate per unit volume of aquifer representing fluid sources (+) and sinks (-), T^{-1}

C_s^k = concentration of source or sink flux for species k , ML^{-3}

$\sum R_n$ = chemical reaction term, $ML^{-3}T^{-1}$

The ULTIMATE (Universal Limiter for Transient Interpolation Modeling of the Advective Transport Equations) algorithm was used to calculate cell interface concentrations (Zheng and Wang, 1999). Several benchmark problems, with comparisons to analytical solutions, were used to develop and validate the MT3DMS code (Zheng and Wang, 1999).

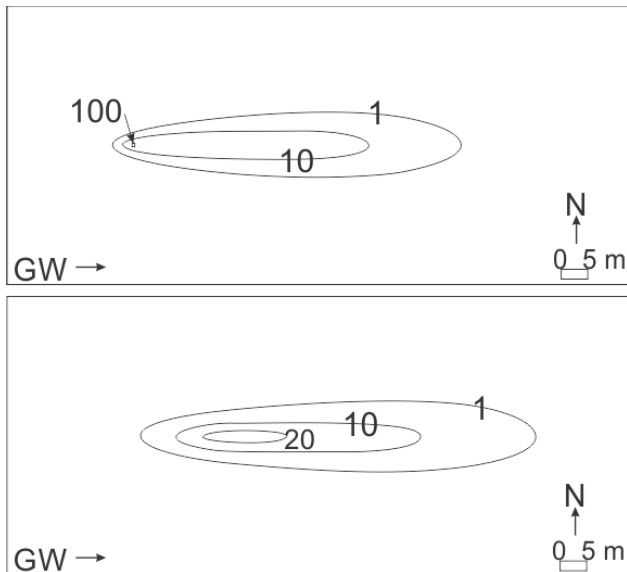

Fig. 1. (Top) Map of contaminant plume (contours in mg/L) after 2,000 days with source on (maximum concentration 100 mg/L). (Bottom) Map of contaminant plume after 500 days with source off (maximum concentration 23.7 mg/L).

The structure of the model included a single layer with 615 columns oriented in a north-south direction and 275 rows oriented in an east-west direction, creating a total of 169,125 cells. The nodes located at the center of each cell were spaced 0.20 m apart along both columns and rows. The hydraulic head at the westernmost column was 5.000 m, while at the easternmost column it was 3.772 m, measured from a reference point at the base of the model. There was no flow across the northern or southern boundaries of the model. On average, the hydraulic gradient in the eastward direction was 0.01. Additional parameters, which are characteristic of an alluvial aquifer according to literature (API, 1989; Gelhar, Welty, Rehfeldt, 1992), included a hydraulic conductivity of 0.5 m/day, an effective porosity of 0.20, a

longitudinal dispersivity of 1.0 m, a transverse dispersivity of 0.1 m, and an effective molecular diffusion coefficient of 0.00001 m^2/day .

The model produced a contaminant plume migrating from a 0.6 m by 0.6 m, 100 mg/L source centered on a node approximately 25 m downgradient of the westernmost model boundary. The source was active for 2,000 days. A concentration of 1.0 mg/L defined the plume's boundary. Remediation trials, commencing after the source was shut off, involved no-action, sleeved extraction and injection (Scheme 0), and sleeved extraction and injection augmented with non-pumped wells. Three non-pumped wells were used in each augmented scheme, located on different flowlines at the same time interval upgradient of the extraction well, from one to five years, in Schemes 1-5. The extraction well had a (simulated) permeable sleeve around a submersible pump and was located 3 m downgradient of the initial contaminant plume; it was modeled as a contaminant sink with a concentration of 0 mg/L. Hydraulic conductivity was equal to 100 m/day and effective porosity equaled 0.40 at the extraction well.

Each simulation involving an extraction well also involved an injection well, located 3 m upgradient of the initial plume, pumping at the same rate in the opposite direction. Several trials with Scheme 0 were made to identify a minimum pumping rate necessary to contain the plume onsite; this rate was used in all but the no-action remediation trials. The downgradient edge of contaminated groundwater and removal timeframe were identified in each trial. Mass balance errors for all simulations were less than 0.01 %.

3. Results and discussion

The enclave of contaminated groundwater stretched to 33 m from the downgradient boundary after 2,000 days (Fig. 1). With the source off, and no filtration or extraction, the plume grew, but concentrations dropped due to dilution and dispersion (Fig. 1). A higher longitudinal dispersivity and the local hydraulic gradient resulted in more mechanical mixing (spreading) east-west than north-south (Fig. 1). The plume reached the eastern model boundary after approximately 1,100 days.

With the source off, a minimum extraction and injection rate of 0.4 m^3/day contained the contaminant plume. The resulting flow field in Scheme 0 effectively covered the initial plume (Fig. 2). This plume gradually migrated eastward, and after 500 days of pumping, its maximum concentration dropped to 22.7 mg/L. Throughout the pumping period, most of the plume's mass lingered between the two pumping wells (Fig. 2). Ultimately, the plume advanced a maximum distance of 17.0 m past the extraction well and was removed after 2,900 days of pumping (Table 1).

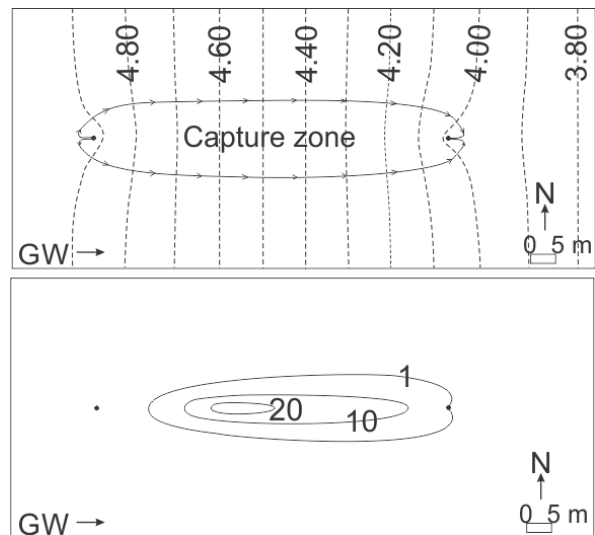

Fig. 2. (Top) Steady hydraulic head contour (m) and flowline (arrows, 1-year time steps) map with extraction (downgradient dot) and injection (upgradient dot) wells. (Bottom) Contour (mg/L) map of contaminant plume after 500 days of extraction and injection (maximum concentration 22.7 mg/L).

Augmenting Scheme 0 with non-pumped filtration wells reduced the maximum remaining concentration, and maximum distance of travel past the extraction well, but had little effect on removal timeframe (Table 1). Non-pumped wells had only localized impact, lowering nearby concentrations, but enabling contaminated groundwater to pass between them (Figs. 3-5). All augmented schemes reduced removal timeframe to approximately 2,800 days. Scheme 3 was most effective

at containment, limiting plume movement past the extraction well to 9.7 m. In Schemes 1 to 3, containment improved as non-pumped wells targeted higher initial concentrations. However, containment worsened in Schemes 4 to 6, as non-pumped wells shifted upgradient, because less contaminated groundwater passed through them.

Table 1. Active remediation summary.

Scenario	Maximum advance past	Time to remove
0	17.0	2,900
1	14.0	2,800
2	11.0	2,800
3	9.6	2,800
4	11.6	2,800
5	14.6	2,800

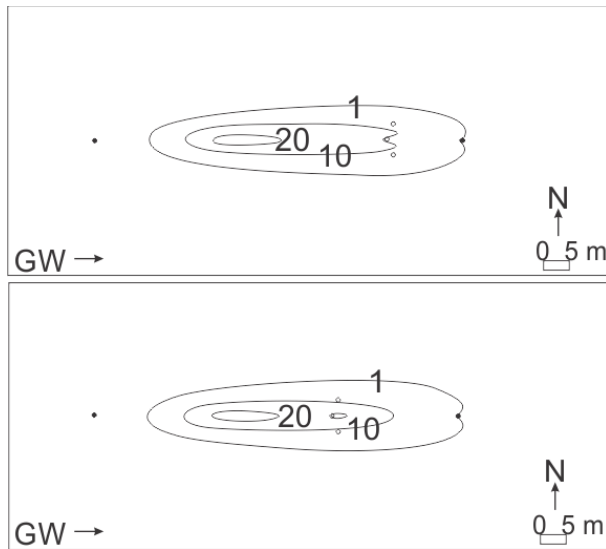

Fig. 3. Contour (mg/L) maps of contaminant plumes after 500 days of extraction and injection augmented with passive well layouts 1 (top, maximum concentration 22.7 mg/L) and 2 (bottom, maximum concentration 22.7 mg/L).

The most effective augmented schemes had non-pumped wells near high contaminant concentrations at the middle of the plume, but not too far upgradient in the plume. For example, after 500 days, Scheme 5 showed the greatest reduction in maximum concentration, because non-pumped wells immediately targeted areas of high concentration, but also allowed the greatest advance past the extraction well, because non-pumped wells contacted less contaminant mass (Fig. 5).

Results of this study suggest that low-discharge extraction wells fitted with filtration sleeves may effectively control and remove contaminant plumes from small source areas. Reinjecting clean water upgradient of a plume helps facilitate its removal. Onsite dilution and hydrodynamic dispersion bolsters remediation. Non-pumped filtration wells were marginally effective at improving containment but may be worthwhile when targeting high concentrations inside a contaminant plume.

Besides those examined in this study, other well placements are possible, but extraction wells placed inside a plume may compete against each other and work against the ambient hydraulic gradient to remove downgradient solute. Placing extraction wells arbitrarily far downgradient of a plume is also problematic, resulting in contaminated groundwater drawn through a larger volume of clean aquifer and possible offsite contamination. Similarly, injection wells should not be placed arbitrarily far upgradient of a contaminant plume.

For non-pumped wells, horizontal orientations have also been evaluated (Divine *et al.*, 2018), but require more expensive drilling equipment and are not effective if the water table falls below them. Additionally, vertical arrays of large-diameter (up to 2 m) non-pumped wells may be feasible in some settings (Bortone *et al.*, 2013), but installation and maintenance, including media replacement, would be time consuming and costly.

In all cases, site conditions should inform aquifer remediation protocols, including pumping rates for sleeved, low-discharge approaches. Ideally, the extraction rate would be low (to save energy), but not excessively prolong remediation, nor allow a plume to move offsite. Neither should discharge rates be too high, thereby consuming more energy and over-drafting wells.

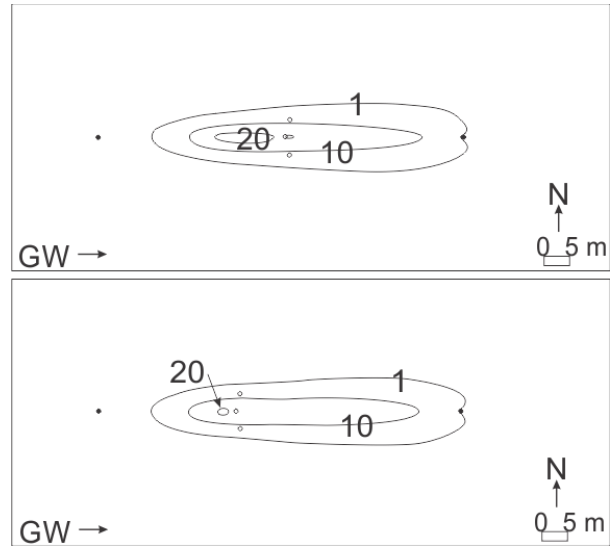

Fig. 4. Contour (mg/L) maps of contaminant plumes after 500 days of extraction and injection augmented with passive well layouts 3 (top, maximum concentration 22.7 mg/L) and 4 (bottom, maximum concentration 20.8 mg/L).

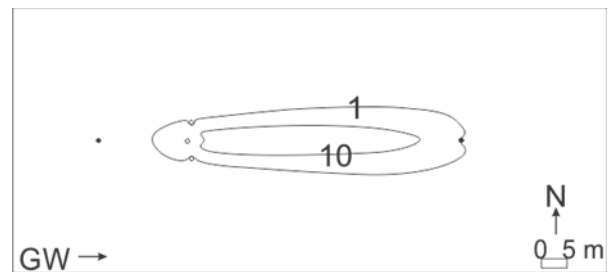

Fig. 5. Contour (mg/L) map of contaminant plume after 500 days of extraction and injection augmented with passive well layout 5 (maximum concentration 19.3 mg/L).

Remediation approaches studied here also have important limitations. Low-discharge wells would not efficiently remove contaminants with low solubility, because they rely upon groundwater to transport solutes. Wide contaminant plumes would require several pumping wells and higher pumping rates. Low groundwater seepage rates would delay movement of pollutants to extraction wells. However, in some low-velocity settings, deploying one or more low-discharge wells could decrease the chance of excessive drawdown associated with high-discharge wells.

4. Conclusions

This study examined the capability of low-discharge wells fitted with submersible pumps and filtration sleeves for recovering narrow zones of contaminated groundwater emerging from lined waste storage facilities. A low-discharge extraction well and upgradient injection well effectively contained and removed a contaminant plume in a case examined here. Augmenting the extraction-injection scheme with non-pumped filtration wells marginally reduced remediation timeframe. The most effective augmented schemes had non-pumped wells at locations with high contaminant concentrations, near the middle of the initial plume. Remediation schemes examined in this study may be useful in some settings with narrow contaminant plumes in groundwater.

Author Contributions

Paul Francis Hudak: Supervision, conceptualization, investigation, methodology, analysis, writing, and editing.

Conflict of Interest

The author declares that he has no known competing financial interests or personal relationship that could have appeared to influence the work reported in this paper.

Acknowledgments

The author thanks the University of North Texas for its support.

Data Availability Statement

The datasets used in the current study are available on request.

References

API (American Petroleum Institute) (1989) *Hydrogeologic database for groundwater modeling*. Washington, D.C.: American Petroleum Institute.

Bortone, I. *et al.* (2013) 'Remediation of an aquifer polluted with dissolved tetrachloroethylene by an array of wells filled with activated carbon', *Journal of Hazardous Materials*, 260, pp. 914-920. doi: <https://doi.org/10.1016/j.jhazmat.2013.06.050>

Caliman, F. A. *et al.* (2021) 'Soil and groundwater cleanup: Benefits and limits of emerging technologies', *Clean Technologies and Environmental Policy*, 13(2), pp. 241-268. doi: <https://doi.org/10.1007/s10098-010-0319-z>

Divine, C. E. *et al.* (2018) 'The horizontal reactive media treatment well (HRX Well) for passive in-situ remediation', *Ground Water Monitoring & Remediation*, 38(1), pp. 56-65. doi: <https://doi.org/10.1002/rem.21571>

Gelhar, L. W., Welty, C., and Rehfeldt, K. R. (1992) 'A critical review of data on field-scale dispersion in aquifers', *Water Resources Research*, 28(7), pp. 1955-1974. doi: <https://doi.org/10.1029/92WR00607>

Hudak, P. F. (2009) 'Interior versus exterior configurations of passive wells with filter cartridges for cleaning contaminated groundwater', *Remediation*, 20(1), pp. 133-141. doi: <https://doi.org/10.1002/rem.20234>

Lee, G. F., and Jones-Lee, A. J. (1994) 'A groundwater protection strategy for lined landfills', *Environmental Science & Technology*, 28(13), pp. 584A-585A. doi: <https://doi.org/10.1021/es00062a718>

Richardson, J. P. and Nicklow, J. W. (2002) 'In situ permeable reactive barriers for groundwater contamination', *Soil and Sediment Contamination: An International Journal*, 11(2), pp. 241-268. doi: <https://doi.org/10.1080/20025891106736>

USGS (U.S. Geological Survey) (1999) *Deep aquifer remediation tools (DARTs): A new technology for ground-water remediation*. Reston, Virginia: U.S. Geological Survey. doi: <https://doi.org/10.3133/fs15699>

Zheng, C., and Wang, P. P. (1999) *MT3DMS, a modular three-dimensional multi-species transport model for simulation of advection, dispersion, and chemical reactions of contaminants in groundwater systems*. Vicksburg, Mississippi: U.S. Army Corps of Engineers.