

Encapsulation of Alpha-Tocopherol Using Polycaprolactone and Tween 20: Formulation and a Perspective for Scaling up Using Micro-Channel

Kaewchada, Amaraporn

*Department of Agro-Industrial Food and Environmental Technology, King Mongkut's University of
Technology North Bangkok, THAILAND*

Tangpromphan, Preuk

Department of Biotechnology, Faculty of Agro-Industry, Kasetsart University, THAILAND

Nakkong, Khwanchanok; Jaree, Attasak^{*+}

*Central of Excellence on Petrochemical and Materials Technology, Department of Chemical
Engineering, Faculty of Engineering, Kasetsart University, THAILAND*

Abstract: Alpha-tocopherol or vitamin E is well known for its beneficial properties for human health. This bioactive compound can be recovered from various agricultural resources through extraction and separation processes. In order to prolong its shelf-life and maintain its bioavailability, the purified substance can be further encapsulated using a biocompatible reagent. In this work, the encapsulation factors including the concentration of polycaprolactone (PCL), concentration of Tween 20, and the ratio of the organic phase to the aqueous phase was experimentally investigated. The Box–Behnken experimental design was employed to determine the optimal encapsulation condition in a small batch system. The results revealed that, at the adjusted optimal condition, 98.43% encapsulation was achieved using the concentrations of PCL of 6 g/L, concentration of Tween 20 of 0.5 g/L, and the ratio of organic phase to aqueous phase of 1:2. Based on the optimal condition of the batch process, the continuous micro-channel encapsulator was employed for continuous encapsulation with different residence times. For the residence time of 1 s, this system provided the encapsulation efficiency of 92.48% with an outstanding productivity of 73.99 mg/mL·min. This work can be further developed to increase the production capacity via parallel processing of micro-channels.

KEYWORDS: Alpha-tocopherol; Box-Behnken; Encapsulation; Micro-channel.

INTRODUCTION

Vitamin E has been perceived as one of the essential ingredients widely used in functional foods, pharmaceuticals

and cosmetics [1,2]. It is a group of natural fat-soluble substances including α , β , γ and δ derivatives of

** To whom correspondence should be addressed.*

+E-mail address: E-mail: fengasj@ku.ac.th

1021-9986/2023/7/2248-2259

12/\$/6.02

tocopherol and tocotrienol. α -tocopherol is considered the most biologically active form of vitamin E amongst others [1,3-5]. At a sufficient level of α -tocopherol intake, various health benefits such as preventing cardiovascular disease, diabetes, carcinogenesis, and neurological diseases as well as inducing autophagy have been demonstrated [1, 3-6]. Moreover, vitamin E is used in cosmetic applications due to its outstanding antiaging properties for the reduction of fine lines and wrinkles, the protection against UV light [5,7].

The stability of vitamin E in the natural environment is an important issue as it is sensitive to light, heat and oxygen. Moreover, it has a low solubility in aqueous media [1,4,6]. In order for vitamin E to be utilized in an active form with full potentials, it has to be well-protected during exposure to high temperature, moisture, UV radiation, etc. Materials for the encapsulation and equipment for efficient mixing are crucial for developing the desired encapsulated particles. *Ribeiro et al.* applied spray-drying technique to encapsulate vitamin E using different biopolymers as wall materials such as sodium alginate maltodextrin, arabic gum, etc. The encapsulation efficiency in the range of 70.1-99.4% was obtained with the particle size in the range of 4.3-25.1 μm , while the release of vitamin E was strongly correlated with the type of wall material. For fast release applications, sodium alginate, inulin and maltodextrin were suitable. On the contrary, the use of arabic gum, modified chitosan, starch and modified starch resulted in a slow release [8]. In the work of *Hategekimana et al.*, vitamin E loaded nanocapsules were produced using high-pressure homogenizer (120 MPa/5 passes) and spray dryer while Octenyl Succinic Anhydride (OSA) and modified starches were used as emulsifiers and wall materials, respectively. The nanocapsules retained 50% of vitamin E after 60 days of storage at 4-35°C [9]. *Shanshan et al.* used triacylglycerol (corn oil) as carrier oil and quillaja saponin as biosurfactant to encapsulate vitamin E using a dual-channel microfluidizer operating at 14,000 psi. The bioaccessibility of encapsulated vitamin E via plant-based nanoemulsion did not decrease after 12 weeks of storage at refrigerated temperatures [10]. Complex coacervation between cationic polyelectrolyte chitosan and oppositely charged anionic surfactant was used to prepare vitamin E microcapsules by means of homogenization followed by spray drying. For the preparation without a cross-linking agent, the release of vitamin E was mainly controlled by diffusion (preventing the burst effect) [11].

The use of a high-pressure homogenizer to prepare the emulsion prior to the application of a spray dryer is energy-intensive. However, much of the energy is dissipated as heat and scaling-up is not straightforward. Most studies used batch system encapsulation, which has some major drawbacks in terms of productivity, energy efficiency, and scaling up. Microchannels or microtubes not only offer the feature of continuous production, but they have also been successfully applied as micromixers for efficient mixing in many applications such as gas-liquid mixing as in CO_2 absorption [12,13], liquid-liquid reaction/extraction [14,15], etc. This effect is generally used to promote reaction(s) with or without the presence of a catalyst. Apart from the excellent transport properties in the microtube/microchannel, the numbering up technique is used to increase the production capacity. This can be implemented by designing flow distributor(s), flow collector(s), and stack(s) of multi-channel plates. The number of plates can be related to the required production capacity. This is generally perceived as a flexible means for intensifying the process. For the application of biodiesel production, it was estimated that the footprint and energy consumption of the production unit may be reduced to one-third of the conventional production plant [16]. *Sawayama* and *Takeuchi* used a centrifuge-based microfluidic device to formulate core-shell microparticles in a batch system [17]. *Bitar et al.* performed encapsulation for pancreatic beta cell via emulsification in a straight-through microchannel (700 x 200 μm). The average bead diameter was $\sim 700 \mu\text{m}$ and the encapsulated cell viability of approximately 89% was achieved [18]. However, such device has rarely been used for the preparation of encapsulated materials, especially vitamin E.

As one of the bio-degradable polymers, polycaprolactone (PCL) has been widely used in the fields of three-dimensional bioprinting of bioactive scaffolds [19,20], nanocomposite membranes [21], amphiphilic hydrogels [22], and matrix for controlled release [23,24]. It has also been approved by the Food and Drug Administration (FDA) for applications used in human body such as drug delivery device, adhesion barrier, etc [25]. *Fagundes et al.* used PCL to encapsulate the Nerol compound with the encapsulation efficiency of 91.42%. The PCL-Nerol capsules were stable for at least 60 days [26]. In another application, PCL was applied to encapsulate isocyanate in the form of spherical, disaggregated, and core-shell MCs

for the application of green adhesives [27]. For the encapsulation of vitamin E, PCL has been used to encapsulate α -tocopherol via O/W emulsion with ultrasonification technique and solvent evaporation *via* freeze drying. The size of polydispersed spheres and the encapsulation efficiency (24.91-96.42%) were strongly correlated with composition of solvent, PCL concentration, and ultrasonification time [28].

Emulsifying agent is an important component for the encapsulation process. Among different variety of emulsifying agents, Tween 20 (also known as polysorbate 20) is regarded as an effective emulsifier for O/W applications in food and cosmetics. Due to the low toxicity, it has been suggested as a safe excipient for various pharmaceuticals administered intramuscularly [29]. Moreover, the European Food Safety Authority suggested an acceptable daily intake (ADI) of 25mg/kg body weight (bw)/day [30]. *Aboudzadeh et al.* demonstrated the encapsulation of α -Tocopherol (loaded in lemon oil, IPPM, and IAAC) in the form of fully food-grade nanodroplets using Tween 20/glycerol as surfactant and the cosurfactant, respectively [31]. The average size of the droplets was in the range of 8.38–19.21 nm. However, the percentage of encapsulation was not reported, and the optimization of the encapsulation formula was not performed. Tween 80, another variation of polysorbate, was also used for the encapsulation of α -tocopherol [32,33].

According to the literature, the optimization using Box-behnken design and Response Surface Methodology (RSM) for developing the formula of vitamin E encapsulation with PCL as shell material and Tween 20 as surfactant has not been reported. The aim of this research was to develop the formula for food-grade nanoencapsulation of vitamin E by optimizing the process conditions in terms of the ratio of organic phase to aqueous phase, the concentration of PCL, and the concentration of Tween 20 in a batch process. The optimized formula based on the percentage of encapsulation will then be applied for the continuous encapsulation using a micro-channel encapsulator. The percentage of encapsulation and productivity obtained from batch and continuous experiments were compared.

EXPERIMENTAL SECTION

Materials

α -Tocopherol (vitamin E) with a purity of greater than 96% and polycaprolactone (PCL) with the molecular weight of 14,000 were both purchased from Sigma Aldrich

(St. Louis, USA). Tween 20 was supplied by Merck (Darmstadt, Germany). Distilled Deionized Water (DDW) with a conductivity of 18 m Ω -cm was used as a solvent for Tween 20. Acetone (analytical grade) and methanol (HPLC grade) were obtained from Merck (Darmstadt, Germany).

Preparation of organic phase and aqueous phase

The organic phase was prepared by first dissolving PCL in acetone. The solution mixture was agitated until the solid was completely dissolved. After that, α -Tocopherol was added to the obtained solution. The concentration of vitamin E was 4 g/L. The concentration of PCL in the mixture was varied in the range of 2-8 g/L. The organic phase solution was analyzed by HPLC to quantify the initial content of vitamin E. For the preparation of the aqueous phase, Tween 20 was dissolved in DDW water to obtain the concentration in the range of 0.5-2 g/L. A vortex mixer (CTL-107, Canada) was used at 3,000 rpm, at room temperature (30 °C) for 5 min to provide vigorous mixing in order to facilitate the preparation of both the organic phase and aqueous phase.

Encapsulation process in a batch mixer

For a typical experiment, the prepared organic phase and aqueous phase solutions were mixed in a controlled-temperature batch shaker (Grant-Bio PHMT Thermoshaker, Cambridgeshire, United Kingdom). The organic liquid was gently dropped into the aqueous phase. The volumetric ratio of organic phase to aqueous phase was varied from 1:1 to 1:8 (the volume of organic phase was fixed as 1 mL). The shaking speed of 650 rpm was used to provide vigorous mixing during the encapsulation process. The temperature was maintained at 40 °C by means of convection heating and each experiment lasted for 5 min. After that, the sample was centrifuged (Microcentrifuge, IBI IMC-15, USA) at the speed of 15,000 rpm for 10 min. The supernatant and precipitated solid obtained were treated separately. The supernatant liquid was collected for the analysis of Vitamin E by HPLC. The percentage of encapsulation (%EC) was calculated using Equation (1).

$$\%EC = \frac{C^I V^O - C^R V^S}{C^I V^O} \times 100 \quad (1)$$

where, C^I is the initial concentration of vitamin E in the organic phase (g/L). V^O is the volume of the organic phase solution (mL). C^R is the concentration of vitamin E in the supernatant liquid, collected after encapsulation process (g/L). V^S is the volume of supernatant liquid (mL).

Table 1: The Box-behnken experimental design for batch encapsulation.

Run	PCL concentration	Tween 20 concentration	Volumetric ratio (mL: mL)	
	(g/L)	(g/L)	Organic	Aqueous
1	2	0.5	1	4.5
2	5	0.5	1	1
3	5	0.5	1	8
4	8	0.5	1	4.5
5	2	1.25	1	1
6	2	1.25	1	8
7	5	1.25	1	4.5
8	5	1.25	1	4.5
9	5	1.25	1	4.5
10	8	1.25	1	1
11	8	1.25	1	8
12	2	2	1	4.5
13	5	2	1	1
14	5	2	1	8
15	8	2	1	4.5

The encapsulated particles (after removing the supernatant liquid) were washed with DDW water. After that the mixture was centrifuged at 15,000 rpm for 10 min. The supernatant liquid was discarded, and the precipitated solid was re-dispersed in DDW water for further analysis. The productivity of the batch encapsulation (mg/mL·min) was determined using Eq. (2).

$$\text{Prod} = \frac{C^I V^O - C^R V^S}{V^W t_b} \quad (2)$$

Where, V^W is the working volume (1.5 mL). t_b is the time period of batch encapsulation (5 min).

All encapsulation parameters (concentration of PCL, concentration of Tween 20, and ratio of organic to aqueous phase) were optimized using Box-Behnken experimental design. The experimental conditions are summarized in Table 1. The optimal conditions were used to scale up the process capacity to the volume of 7.5 mL. The mixing was provided by means of magnetic stirring performed at 40 °C for 5 min. The method for purifying the encapsulated product was the same as previously described.

Encapsulation process in a micro-channel encapsulator

The schematic diagram of a micro-channel encapsulator is represented in Fig. 1. Two syringe pumps

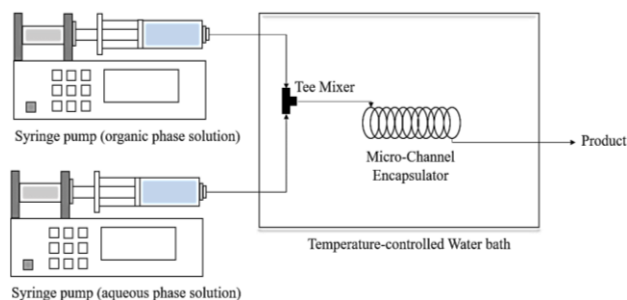

Fig. 1: Schematic diagram of a micro-channel encapsulator

were employed for delivering organic phase and aqueous phase solutions. These streams were merged at a T-mixer. The encapsulation took place as the combined stream propagated through a micro-channel made of PEEK with an inside diameter of 0.0558 cm and the length of 90 cm. The micro-channel, T-mixer, and pre-heaters were submerged in a water bath equipped with internal circulation to maintain the constant temperature of 40 °C. The flow rate ratio of organic phase to aqueous phase was determined according to the optimal conditions of the batch encapsulation. The residence time in the micro-channel was varied from 1 s to 5 min by adjusting the individual flow rate of input streams. Note that the flow rate of each stream was changed by the same factor in order to maintain the constant flow rate ratio. For each experiment, the sample of 1.5 mL was collected at the exit end of the micro-channel after operating the system for a certain period of time (at least threefold of the residence time). The sample was purified by the same procedure as previously described in section 2.3. Again, the supernatant liquid was analyzed by HPLC for the quantification of vitamin E. The percentage of encapsulation in a micro-channel was calculated by Eq. (3).

$$\%EC = \frac{C^F Q^O - C^{RP} Q^P}{C^F Q^O} \times 100 \quad (3)$$

Where C^F is the feed concentration of vitamin E prepared in the organic phase (g/L). Q^O is the volumetric flow rate of the organic phase solution (mL/min). C^{RP} is the concentration of vitamin E in the outlet product (g/L). Q^P is the volumetric flow rate of the outlet product (mL/min).

The productivity of the continuous encapsulation (g/L·min) can be calculated by Eq. (4).

$$\text{Prod} = \frac{C^F Q^O - C^{RP} Q^P}{V^T} \quad (4)$$

Where, V^T is the volume of the tube (mL).

Table 2: The efficiency of batch encapsulation.

Run	Molar Ratio (Mole: Mole: Mole)			%Encapsulation (% EC)		Productivity (mg/(mL·min))	
	Vitamin E	PCL	Tween 20	Mean	SD	Mean	SD
1	1.00	1.89	0.20	48.84	0.609	0.071	0.001
2	1.00	4.72	0.04	99.38	0.024	0.398	0.000
3	1.00	4.72	0.35	75.79	0.030	0.067	0.000
4	1.00	7.55	0.20	90.46	0.449	0.132	0.001
5	1.00	1.89	0.11	75.53	0.359	0.302	0.001
6	1.00	1.89	0.88	30.47	1.034	0.027	0.001
7	1.00	4.72	0.49	71.31	0.226	0.104	0.000
8	1.00	4.72	0.49	70.45	0.455	0.102	0.001
9	1.00	4.72	0.49	69.88	0.161	0.102	0.000
10	1.00	7.55	0.11	99.27	0.014	0.397	0.000
11	1.00	7.55	0.88	82.07	0.246	0.073	0.000
12	1.00	1.89	0.79	27.14	0.402	0.039	0.001
13	1.00	4.72	0.18	97.99	0.115	0.392	0.000
14	1.00	4.72	1.40	65.25	0.083	0.058	0.000
15	1.00	7.55	0.79	83.45	0.044	0.121	0.000

HPLC assay

The concentration of vitamin E was quantified using Knauer HPLC system (Berlin, Germany). The apparatus consisted of a S-1050 HPLC pump, a S-3950 autosampler, a column oven, and a DAD detector. The SUPELCOSIL™ LC-18 column (250 mm × 4.6 mm) with the particle size of 5 μm, purchased from SUPELCO Analytical (Pennsylvania, USA), was used for the analysis. The analysis procedure was adopted from the work of Šuleková [34]. The injection volume was 10 μL. The oven temperature was kept constant at 40 °C. The detector wavelength was 295 nm. Methanol was used as mobile phase at a constant flow rate of 1 mL/min.

RESULTS AND DISCUSSION

Batch encapsulation

Box-Behnken experimental design was applied in order to investigate the effect of the ratio of organic phase to aqueous phase (1:1 to 1:8), the concentration of PCL (2-8 g/L), and the concentration of Tween 20 (0.5-2 g/L) on the encapsulation efficiency. The experiment was performed twice for each condition. The results in terms of the percentage of encapsulation (%EC) and the batch productivity are shown in Table 2. In this system, PCL was employed as the carrier material [35-36] to encapsulate vitamin E and Tween 20 was utilized as the co-surfactant [37] to form the structural linkage between vitamin E and PCL.

It could be noted that the percentage of vitamin E encapsulated depended strongly on the concentration of PCL (X_1) and the ratio of organic phase to aqueous phase (X_3). The maximum encapsulation efficiency occurred at high concentration of PCL, implying that sufficient amount of carrier was provided. The equi-volumetric ratio of organic phase and aqueous phase (the minimum ratio in this set of experiments) resulted in the high amount of vitamin E encapsulated. For instance, for the encapsulation efficiency of 99.38% was achieved with the concentration of PCL of 5 g/L. At this condition, the molar ratio of vitamin E: PCL: Tween 20 was 1.00: 4.72: 0.04. It was observed that when the ratio of organic to aqueous phase was greater than 1:1, the percentage of encapsulation significantly declined. In this system, the threshold molar ratio between PCL and vitamin E of 1:4.72 was required to achieve almost complete encapsulation.

The structure of precipitated solid product was postulated as the encapsulated particle consisting of PCL as a shell or the outer layer, surrounding the core (vitamin E). This was due to the difference in the electron density in the molecule especially around the carbonyl groups of PCL compared to that of tocopherol or vitamin E. The collected sample did not dissolve in water. On the other hand, it could suspend well in water to form colloid-like solution. Based on HPLC analysis of the spent water used in the purification step, no trace of vitamin E was detected, suggesting that vitamin E was successfully encapsulated. The existence of PCL as outer shell material was verified by adding methanol and acetonitrile to the particles. After that, the mixture was analyzed by HPLC for the presence of vitamin E. It was found that a significant amount of vitamin E was found in the solution as shown in Fig. 2 (the scale of the vertical axis is different on both chromatograms). Hence, the outer surface was PCL, which can readily dissolve in the organic solvent, releasing vitamin E into the bulk fluid mixture.

The Response Surface Methodology (RSM) was applied to represent the percentage of encapsulation for the ranges of operating conditions investigated. This was presented in the form of a full quadratic polynomial equation as shown in Eq. (5).

$$Y = \beta_0 + \beta_1 X_1 + \beta_2 X_2 + \beta_3 X_3 + \beta_{11} X_1^2 + \beta_{22} X_2^2 + \beta_{33} X_3^2 + \beta_{12} X_1 X_2 + \beta_{13} X_1 X_3 + \beta_{23} X_2 X_3 \quad (5)$$

Where, X_1 is the concentration of PCL (g/L). X_2 is the concentration of Tween 20 (g/L). X_3 is the ratio of organic

Table 3: The regression coefficients and P-values of the quadratic model.

Coefficient	Response (Y) = Percentage of Encapsulation, EC (%)	
	Value	P-value
β_0	70.55	0.000
β_1	21.66	0.000
β_2	-5.08	0.026
β_3	-14.82	0.000
β_{11}	-10.42	0.007
β_{22}	2.35	0.369
β_{33}	11.71	0.004
β_{12}	3.67	0.169
β_{13}	6.96	0.028
β_{23}	-2.29	0.363

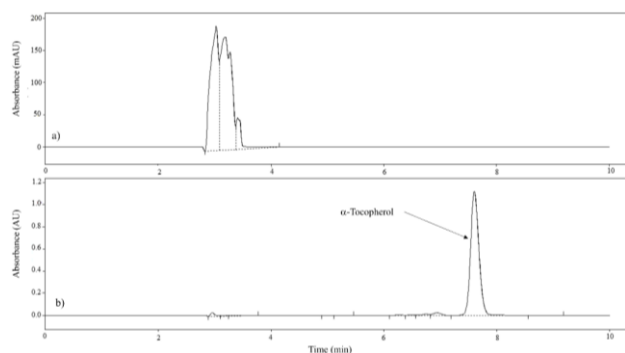
**Fig. 2: Chromatograms indicating the presence of α -tocopherol in a) spent water 2) after adding methanol.**

phase to aqueous phase. Y is the percentage of encapsulation. β_i is the constant for each term. The coefficients of the quadratic polynomial equation and the associated P-values are presented in Table 3.

The quadratic polynomial equation represented the experimental data well with r -squared and adjusted r -squared of 0.9841 and 0.9784, respectively. According to Table 2, all terms were significant (P -value < 0.05 for 95% confidence) except for the squared concentration of Tween 20 (β_{22}), the interaction between the concentration of PCL and the concentration of Tween 20 (β_{12}), and the interaction between the concentration of Tween 20 and the ratio of organic to aqueous phase (β_{23}). The quadratic polynomial equation and its coefficients obtained from RSM was used to predict the optimal operating conditions providing the highest percentage of encapsulation. All terms were kept in the model to achieve high accuracy of prediction. The surface and contour plots representing the effect of three encapsulation

parameters (concentration of PCL, the concentration of Tween 20, and the ratio of aqueous phase to organic phase) on the %EC are shown in Fig. 3. As previously discussed, the ratio of the aqueous phase to the organic phase should be kept as unity. For the concentration of Tween 20 of 0.50 g/L, the concentration of PCL exceeding 6 g/L was sufficient to encapsulate most of vitamin E in the system.

The optimal conditions were predicted at the concentration of PCL of 7.63 g/L, the concentration of Tween 20 of 2.0 g/L, and the ratio of the organic to aqueous phase of 1:1. However, the handling of the encapsulated product obtained at this condition was difficult as the particles adhered to each other and to the surface of the container. Furthermore, the product could not disperse well in water in the purification step. This was probably caused by the excess PCL for conditions with high concentrations of PCL or with a relatively large ratio of organic to aqueous phase. Note that PCL has a low solubility in water. Therefore, we decreased the concentration of PCL to 6 g/L as well as decreased the ratio of organic phase to aqueous phase to 1:2 to facilitate the flow of product. According to the statistical analysis, the effect of the concentration of Tween 20 on the percentage of encapsulation was not significant. Hence, the concentration of Tween 20 was diluted to 0.5 g/L (the lowest level in this study) to reduce the material cost. Table 4 shows the experimental results in terms of %EC and batch productivity at this condition. Although the experimentally obtained %EC of 98.43% was slightly lower than that of the predicted value of 96.08%, it was considered appropriate and was used as a base case for comparison of the encapsulation performance achieved using different systems. This modified optimal condition offered an acceptable encapsulation performance, batch productivity, and good characteristics of the final solid product. This condition was used as a basis for determining the flow rate of each stream of solution in the continuous encapsulation using a micro-channel encapsulator.

Continuous encapsulation

To increase the productivity of encapsulation process, the micro-channel encapsulator as shown in Fig. 1, was employed. The specification of the encapsulator was previously mentioned in section 2.4. There were two reservoirs for the feed solutions: one for PCL/vitamin E solution and another one for aqueous solution of Tween 20.

Table 4: The adjusted optimal condition of batch encapsulation and the obtained results.

PCL Concentration (g/L)	Tween 20 Concentration (g/L)	Volumetric ratio		%EC		Productivity (mg/(mL·min))
		Organic	Aqueous	Experiment	RSM model	
6	0.5	1	2	98.43	96.08	0.26

Table 5: Experimental conditions of the continuous encapsulation.

Organic Phase Flow rate (mL/min)	Aqueous Phase Flow rate (mL/min)	Total Flow rate (mL/min)	Volume of Micro-channel (mL)	Residence time (min)
0.015	0.029	0.044	0.220	5.000
0.024	0.049	0.073	0.220	3.000
0.073	0.147	0.220	0.220	1.000
0.147	0.294	0.441	0.220	0.500
0.294	0.588	0.881	0.220	0.250
0.881	1.763	2.644	0.220	0.083
4.407	8.813	13.220	0.220	0.017

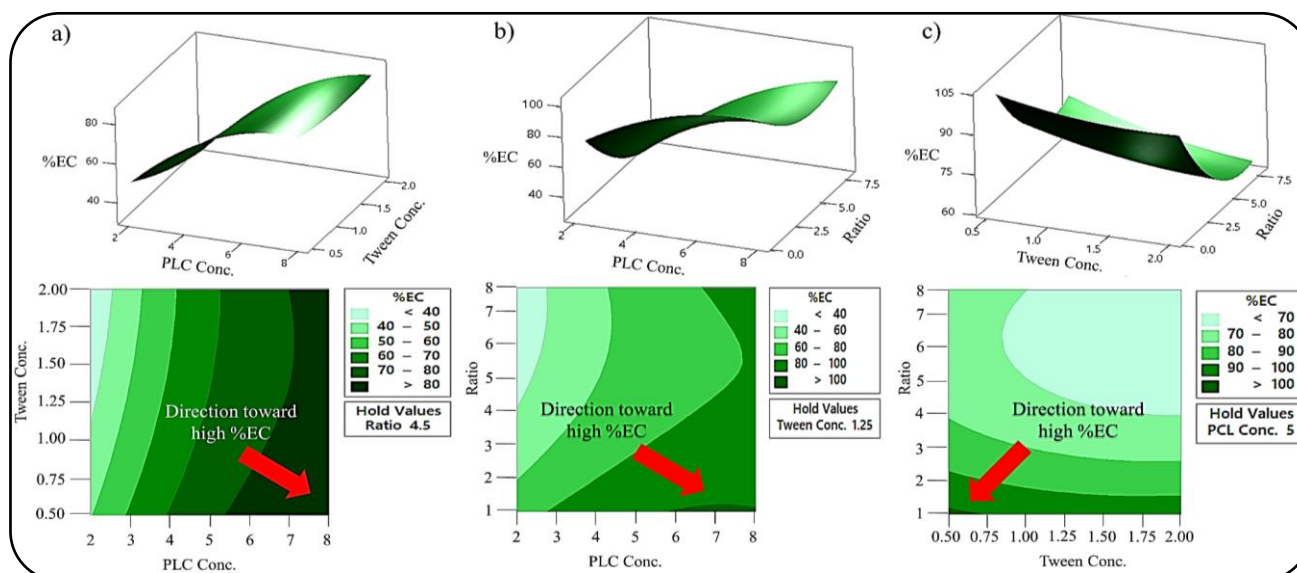

Fig. 3: The surface and contour plots of encapsulation (%EC) for different pairs of encapsulation parameters. a) concentration of PCL and concentration of Tween 20 b) concentration of PCL and ratio of aqueous phase to organic phase c) concentration of Tween 20 and ratio of aqueous phase to organic phase.

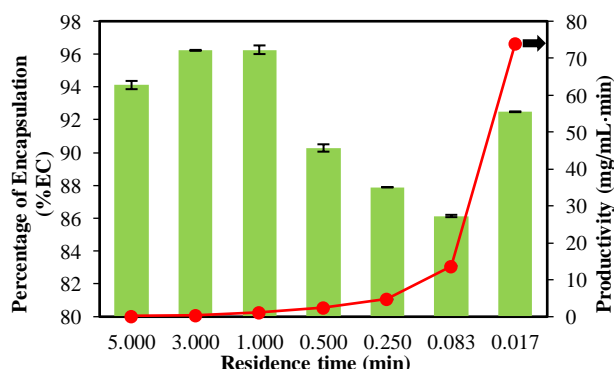

Fig. 4: The productivity and the percentage of encapsulation (%EC) of the continuous encapsulation.

The concentration of PCL was 6 g/L and the concentration of Tween 20 was 0.5 g/L. The ratio of the organic phase to the aqueous phase of 1:2 was provided by manipulating the flow rate of each input stream. In this experiment, the residence time was varied from 5 min to 1 s. The experimental conditions are presented in Table 5 and the results of %EC and productivity are shown in Fig. 4.

As observed in Fig. 4, a high percentage of encapsulation in the range of 94-96% was achieved at the residence time of 5, 3, and 1 min. Note that decreasing the residence time was associated with increasing the flow rate of each feed stream, which resulted in a more intensified mixing at the

Table 6: The experimental results of various modes of encapsulation.

System	Volume of Mixture (mL)	Encapsulation time (min)	Volumetric ratio of organic to aqueous Phase	%Encapsulation (% EC)		Productivity (mg/(mL.min))	
				Mean	SD	Mean	SD
Batch	7.500	5.00	1: 2	72.46	1.81	0.04	0.001
Batch	1.500	5.00	1: 2	98.43	0.00	0.26	0.000
Continuous	0.220	5.00	1: 2	94.51	0.23	0.25	0.001

T-mixer. A slight increase of %EC was found in this range. At the residence time of 1 min, the productivity of the continuous encapsulation was approximately 5 times that of the batch process. Further decreasing the residence time to 0.5, 0.25, and 0.083 min caused the %EC to markedly drop to 90.28%, 87.89%, and 86.14%, respectively. Although the intensified mixing was provided, the residence time was not sufficient for the complete encapsulation. Nevertheless, the productivity of this process increased at an increasing rate. Interestingly, when the residence time was decreased to 0.017 min, a significantly improved %EC of 92.48% was achieved. This implied that the mixing and diffusion of all species were relatively more facilitated compared to the cases with the residence time of 5, 3, and 1 min. At this level of %EC, the encapsulation performance was considered satisfactory. Hence, the optimal condition for continuous encapsulation in the micro-channel was chosen at the residence time of 0.017 s. At this condition, the productivity of 73.99 mg/mL.min was extremely high (about 285 times higher than that of the batch encapsulation).

Comparison of encapsulation in different systems

In this section, the encapsulation performance of batch and continuous systems was compared. For the batch system, two experiments were performed with the same parameters as previously reported in Table 4 except that the total volume was 7.5 mL. This represented the operating condition that was far from the ideal mixing condition. For the continuous encapsulation, the residence time of 5 min was used for comparison. Table 6 summarizes the operating conditions and the encapsulation performance in terms of %EC and productivity. Apparently, the larger batch system performed poorly since all species were not uniformly distributed during encapsulation. This issue can be critical for industrial-scale processes. In that case, the encapsulation may require a much longer period of time to achieve the same level of %EC. The continuous encapsulation in a micro-channel provided a high percentage of encapsulation

comparable to that of the smaller batch system. However, the productivity of the continuous encapsulation system could be significantly improved by lowering the residence time to 1s as previously discussed. Besides, the micro-tube system can be arranged for parallel processing in the form of stacks. Hence, the footprint of the encapsulation process can be considerably reduced by taking advantage of micro-tube and continuous production.

Fig. 5 shows particle size distribution of the encapsulated particles for different operating conditions. Four cases designated as a, b, c, and d are given full details in Table 7. The size of all samples was in the range of nanoparticles except that large particles were also formed for the case of 7.5 ml batch experiment. The size distribution was relatively broader than other cases. This was conceivably due to poor mixing. For the case of micro-channel with the residence time of 1 s, the average particle size was 464.25 nm, which was significantly smaller than the case of a micro-channel with a residence time of 5 min (750 nm). The small residence time in the micro-channel was associated with a high flow rate, leading to the intensified mixing of all species involved in the encapsulation process and the formation of small droplets as the mixture propagated through the micro-channel. Note that the particle surface charge (zeta potential) of all samples was lower than -30 mV, indicating the high electrostatic stability of encapsulated particles [38].

Based on the average particle size, %EC, and encapsulation productivity, the micro-channel encapsulator can be considered as an efficient tool for producing encapsulated vitamin E. These results can be used to further develop the high-capacity production unit using stacks of micro-channels. A compact design of microchannels sandwiched between a flow distributor and a flow collector will result in a small footprint of the processing unit. Note that the flow behavior, transport phenomena, and interaction among chemical species in every channel will be mostly the same. Hence, the optimal operating conditions obtained in this work can be applied.

Table 7: The experimental results from various modes of encapsulation.

Case	System	Retention time	%EC ± SD	Mean diameter (nm) ± SD	PdI ± SD	Zeta potential (mV) ± SD
A	Batch 1.5 ml	5 min	98.43 ± 0.00	616 ± 6.29	0.47 ± 0.00	-33.10 ± 0.57
B	Batch 7.5 ml	5 min	72.46 ± 1.81	353 ± 3.11	0.36 ± 0.02	-37.75 ± 1.06
C	Micro-channel	5 min	94.51 ± 0.23	0.67 ± 0.05	-33.50 ± 0.14	
D	Micro-channel	1 s	92.98 ± 0.02	464.25 ± 4.17	0.65 ± 0.02	-39.95 ± 0.78

Table 8: The comparison of vitamin E encapsulation in different systems.

Formula	Conditions	Particle size	Reference
86.78% water, 3.0% WPI, 3.5% orange oil, 3.0% sweetener, 2.0% fibre, 0.7% citric acid, 1.0% colouring agents, 0.02% tocopherols	Mixing in a high-speed blender (2 min) followed by homogenization at 25 MPa and 8 MPa for 1 st and 2 nd passage through the homogenization valve.	-	[39]
Gum arabic-Quillaja saponin-whey protein isolate (1.5%) Oil phase: corn oil (80%), vitamin E (20%)	Three passes in a microfluidizer at 12,000 psi	<100 nm	[40]
Oil phase: oil composition of 8% VE + 2% MCT (medium chain triglyceride) Surfactant: 10 wt.% Tween 80 (in final mixture) Aqueous phase: pH 3.0, 0.8% citric acid, 0.08% sodium benzoate	Magnetic stirrer at 800 rpm (25 °C). The oil (10 g) and surfactant (10 g) were first mixed together and then the mixture was slowly poured into 80 g of aqueous phase over a 15 min period.	< 50 nm	[41]
Oil phase: 0.4% vitamin E Surfactant: Tween 40	Three stages of high-pressure homogenization at 10,000 rpm and 500 bar (10 min)	~200 nm	[42]
Oil phase: vitamin E and PCL in acetone Aqueous phase: Tween 20 in DDW	Mixing in a T-microchannel (0.0558 cm ID. and 90 cm long) with the residence time of 0.017 s	<500 nm	This work

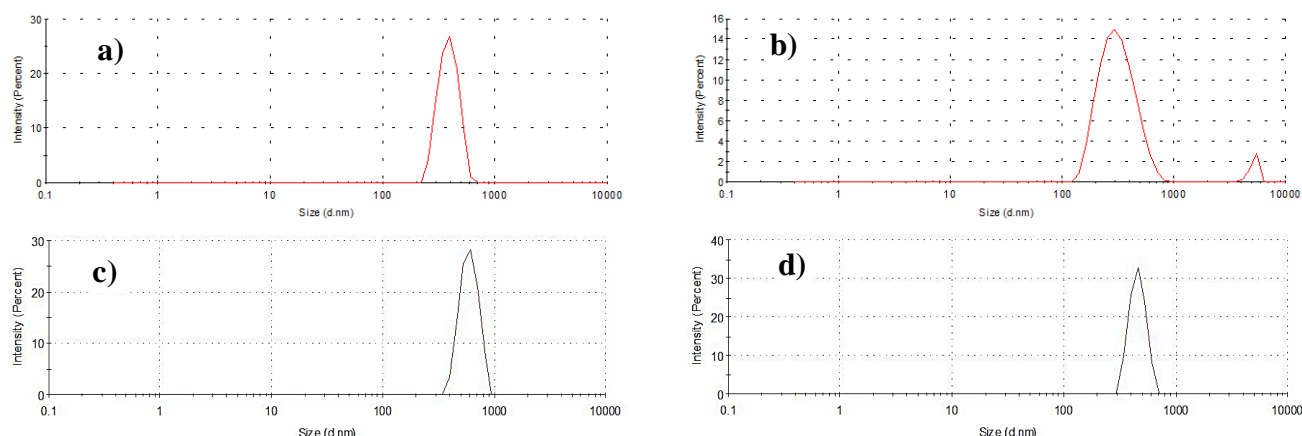

Fig. 5: Particle size distribution of encapsulated vitamin E obtained from a) 1.5 mL batch b) 7.5 ml batch c) micro-channel 5 min d) micro-channel 1 s.

Table 8 presents the comparison of vitamin E encapsulation in different systems reported in the literature. The procedure and encapsulation formula for each system are different from other systems. In general, energy-intensive devices have been used to prepare the encapsulated vitamin E such as microfluidizer, high-pressure homogenization, etc. Conceivably, this has a certain impact on the economic aspect of the production. This work offers another method for the encapsulation of vitamin E in a continuous system. The pressure was less

than 2 bar and the equipment is relatively simple. The residence time of 0.017 s for our system was much shorter than the time required for each batch in other systems. Unlike batch processing, this process is flexible in terms of adjusting the production capacity via the numbering up technique, which does not significantly affect the pressure drop in the system. Although the encapsulated particles obtained in our system were relatively large compared to other systems, it is possible to apply a more advanced micro-mixer to further decrease the particle size.

CONCLUSIONS

The encapsulation of vitamin E was demonstrated in both batch and continuous systems. The encapsulation formula involving the ratio of organic phase to aqueous phase, the concentration of PCL, and the concentration of Tween 20 was optimized based on the Box-Behnken experimental design and the RSM of the percentage of encapsulation. The optimal conditions were at the ratio of organic phase to aqueous phase of 1:1, the concentration of PCL of 7.63 g/L, and the concentration of Tween 20 of 2.0 g/L. In order to facilitate the handling of samples, the optimal conditions were slightly modified as the concentration of PCL of 6 g/L, the concentration of Tween 20 of 0.5 g/L, and the ratio of the organic phase to the aqueous phase of 1:2, providing the encapsulation efficiency and productivity of 98.43% and 0.26 mg/mL·min, respectively. This was used to as a basis to develop the encapsulation conditions in the micro-channel encapsulator. The effect of residence time on the %EC and productivity was investigated. The optimal residence time was 0.017 s, providing the productivity of 73.99 mg/mL·min and the %EC of 92.48%. This work can be used as the foundation for further developing the large-scale production of encapsulated vitamin E.

Acknowledgements

This research was funded by King Mongkut's University of Technology North Bangkok. Contract no. KMUTNB-61-GOV-D-63. Valuable suggestions from Ms. Naruthai Hongsa is appreciated.

Received: May. 13, 2022 ; Accepted: Jul. 25, 2022

References

- [1] Yang Y., McClements D.J., [Encapsulation of Vitamin E in Edible Emulsions Fabricated Using a Natural Surfactant](#), *Food Hydrocolloids (FOHYES)*, **30**: 712-720 (2013).
- [2] Chiu Y.C., Yang W.L., [Preparation of Vitamin E Microemulsion Possessing High Resistance to Oxidation in Air](#), *Colloids Surfaces.*, **63**: 311-322 (1992).
- [3] Karim M.R., Fujimura S., Kadowaki M., [Vitamin E as a Novel Enhancer of Macroautophagy in Rat Hepatocytes and H4-II-E Cells](#), *Biochemical and Biophysical Research Communications*, **394**: 981-987 (2010).
- [4] Saberi A.H., Fang Y., McClements D.J., [Fabrication of Vitamin E-Enriched Nanoemulsions: Factors Affecting Particle Size Using Spontaneous Emulsification](#), *Journal of Colloid and Interface Science*, **391**: 95-102 (2013).
- [5] Morais Diane J.M., J. Burgess, [Vitamin E Nanoemulsions Characterization and Analysis](#), *International Journal of Pharmaceutics (IJPHDE)*, **465**: 455-463 (2014).
- [6] Sharipova A.A., Aidarova S.B., Grigoriev D., Mutaliev B., Madibekova G., Tleuova A., Miller R., [Polymer-Surfactant Complexes for Microencapsulation of Vitamin E and its Release](#), *Colloids and Surfaces B: Biointerfaces*, **137**: 152-157 (2016).
- [7] Drach M., Narkiewicz-Michalek J., Sienkiewicz A., Szymula M., Bravo-Díaz C., [Antioxidative Properties of Vitamins C and E in Micellar Systems and in Microemulsions](#), *Colloids and Surfaces A: Physicochemical and Engineering Aspects*, **379**: 79-85 (2011).
- [8] Ribeiro A.M., Estevinho B.N., Rocha F., [Improvement of Vitamin E Microencapsulation and Release Using Different Biopolymers as Encapsulating Agents](#), *Food and Bioproducts Processing*, **130**: 23-33 (2021).
- [9] Hategekimana J., Masamba K.G., Ma J., Zhong F., [Encapsulation of Vitamin E: Effect of Physicochemical Properties of Wall Material on Retention and Stability](#), *Carbohydrate Polymers*, **124**: 172-179 (2015).
- [10] Lv S., Gu J., Zhang R., Zhang Y., Tan H., McClements D. J., [Vitamin E Encapsulation in Plant-Based Nanoemulsions Fabricated Using Dual-Channel Microfluidization: Formation, Stability, and Bioaccessibility](#), *Journal of Agricultural and Food Chemistry*, **66**: 10532-10542 (2018).
- [11] Budincic J.M., Petrovic L., Đekic L., Fraj J., Bucko S., Katona J., Spasojevic L., [Study of Vitamin E Microencapsulation and Controlled Release from Chitosan/Sodium Lauryl Ether Sulfate Microcapsules](#), *Carbohydrate Polymers*, **251**: 116988 (2021).

- [12] Makcharoen M., Kaewchada A., Akkarawatkhosith N., Jaree A., [Biojet Fuel Production via Deoxygenation of Crude Palm Kernel Oil Using Pt/C as Catalyst in a Continuous Fixed Bed Reactor](#), *Energy Conversion and Management: X*, **12**: 100125 (2012).
- [13] Akkarawatkhosith N., Kaewchada A., Jaree A., [High-Throughput CO₂ Capture for Biogas Purification using Monoethanolamine in a Microtube Contactor](#), *Journal of the Taiwan Institute of Chemical Engineers*, **98**: 113-123 (2019).
- [14] Tongtummachat T., Akkarawatkhosith N., Kaewchada A., Jaree A., [Conversion of Glucose to 5-Hydroxymethylfurfural in a Microreactor](#), *Frontiers in Chemistry*, **7**: 951 (2020).
- [15] Pumrod S., Kaewchada A., Roddecha S., Jaree A., [5-HMF Production from Glucose Using Ion Exchange Resin and Alumina as a Dual Catalyst in a Biphasic System](#), *RSC Advances*, **10**: 9492-9498 (2020).
- [16] Akkarawatkhosith N., Srichai A., Kaewchada A., Ngamcharussrivichai C., Jaree A., [Evaluation on Safety and Energy Requirement of Biodiesel Production: Conventional System and Microreactors](#), *Process Safety and Environmental Protection*, **132**: 294-302 (2019).
- [17] Sawayama J., Takeuchi S., "Core-Shell Microparticles Formation with Centrifugal Coaxial Microfluidic Device", IEEE 29th International Conference on Micro Electro Mechanical Systems (MEMS), Shanghai, China, (2016).
- [18] Bitar C.M.E., Markwick K.E., Trefová D., Kroneková Z., Pelach M., Selerier C.M.O., Dietrich J., Lacík I., Hoesli C.A., [Development of a Microchannel Emulsification Process for Pancreatic Beta Cell Encapsulation](#). *Biotechnology Progress*, **35**: 2851 (2019).
- [19] Kim D., Lee J., Seok J.M., Jung J.-Y., Lee J.H., Lee J.S., Lee K., Park S.A., [Three-Dimensional Bioprinting of Bioactive Scaffolds with Thermally Embedded Abalone Shell Particles for Bone Tissue Engineering](#), *Materials & Design*, **212**: 110228 (2021).
- [20] Zhang W., Zhao W., Li Q., Zhao D., Qu J., Yuan Z., Cheng Z., Zhu X., Zhuang X., Zhang Z., [3D-Printing Magnesium–Polycaprolactone Loaded with Melatonin Inhibits the Development of Osteosarcoma by Regulating Cell-In-Cell Structures](#), *Journal of Nanobiotechnology*, **19**: 263 (2021).
- [21] Geravand M.H.A., Saljoughi E., Mousavi S.M., Kiani S., [Biodegradable Polycaprolactone/MXene Nanocomposite Nanofiltration Membranes for the Treatment of Dye Solutions](#), *Journal of the Taiwan Institute of Chemical Engineers*, **128**: 124-139 (2021).
- [22] Dabbaghi A., Ramazani A., Farshchi N., Rezaei A., Bodaghi A., Rezayati S., [Synthesis, Physical and Mechanical Properties of Amphiphilic Hydrogels Based on Polycaprolactone and Polyethylene Glycol for Bioapplications: A Review](#), *Journal of Industrial and Engineering Chemistry*, **101**: 307-323 (2021).
- [23] Pouladchang A., Tavanai H., Morshed M., Khajehali J., Shamsabadi A.S., [Controlled Release of Thiram Pesticide from Polycaprolactone Micro and Nanofibrous Mat Matrix](#), *Journal of Applied Polymer Science*, **139**: 51641 (2022).
- [24] Mogrovejo-Valdivia A., Maton M., Garcia-Fernandez M.J., Tabary N., Chai F., Neut C., Martel B., Blanchemain N., [In Vitro Microbiological and Drug Release of Silver/Ibuprofen Loaded Wound Dressing Designed for the Treatment of Chronically Infected Painful Wounds](#), *Antibiotics*, **10**: 10070805 (2021).
- [25] Li L., LaBarbera D.V., [3D High-Content Screening of Organoids for Drug Discovery](#), In *Comprehensive Medicinal Chemistry III*, Elsevier, 388-415 (2017).
- [26] Fagundes P., Carniel T.K., Hall M.C., Colpani G.L., Silva L.L., Zanetti M., Maria J., Mello M., Dalcanton F., Fiori M.A., [Encapsulation of Nerol Oil in Polycaprolactone Polymer and Stability Evaluation](#), *J. Poly. Envir.*, **30**: 125-135 (2022).
- [27] Loureiro M.V., Vale M., Galhano R., Matos S., Bordado J.C., Pinho I., Marques A.C., [Microencapsulation of Isocyanate in Biodegradable Poly\(\$\epsilon\$ -caprolactone\) Capsules and Application in Monocomponent Green Adhesives](#), *ACS Applied Polymer Materials*, **2**: 4425-4438 (2020).
- [28] Byun Y., Hwang J.B., Bang S.H., Darby D., Cooksey K., Dawson P.L., Park H.J., Whiteside S., [Formulation and Characterization of \$\alpha\$ -Tocopherol Loaded Poly \$\epsilon\$ -Caprolactone \(PCL\) Nanoparticles](#), *LWT - Food Science and Technology*, **44**: 24-28 (2011).
- [29] Kim J., Kwak S., Park M.S., Rhee C.H., Yang G.H., [Safety Verification for Polysorbate 20, Pharmaceutical Excipient for Intramuscular Administration, in Sprague-Dawley Rats and New Zealand White Rabbits](#), *PLOS ONE*, **16**: 0256869 (2021).

- [30] Panel on Food Additives and Nutrient Sources added to Food (ANS), [Scientific Opinion on the Re-Evaluation of Polyoxyethylene Sorbitan Monolaurate \(E432\), Polyoxyethylene Sorbitan Monooleate \(E433\), Polyoxyethylene Sorbitan Monopalmitate \(E434\), Polyoxyethylene Sorbitan Monostearate \(E435\) and polyoxyethylene Sorbitan Tristearate \(E436\) as Food Additives](#), *European Food Safety Authority*, **13**: 4152 (2015).
- [31] Aboudzadeh M.A., Mehravar E., Fernandez M., Lezama L., Tomovska R., [Low-Energy Encapsulation of \$\alpha\$ -Tocopherol Using Fully Food Grade Oil-in-Water Microemulsions](#), *ACS Omega*, **3**: 10999–11008 (2018).
- [32] Mohammadzadeh, M., Bostan, A., Kadkhodae, R., [Preparation and Characterization of \$\alpha\$ -Tocopherol-Loaded Nano-Lipid Carriers: Effect of Lipid Type and Carrier Oil Content](#), *Iranian Journal of Chemistry and Chemical Engineering (IJCCE)*, **40(3)**: 715-724 (2021).
- [33] Mehmood T., [Analytical Methods Optimization of the Canola Oil Based Vitamin E Nanoemulsions Stabilized by Food Grade Mixed Surfactants Using Response Surface Methodology](#), *Food Chemistry*, **183**: 1-7 (2015).
- [34] Šuleková M., Hudák A., Smrčová M., [The Determination of Food Dyes in Vitamins by RP-HPLC](#), *Molecules*, **21**: 1368 (2016).
- [35] Koulouktsi C., Nanaki S., Bampalexis P., Kostoglou M., Bikiaris D., [Preparation and Characterization of Alendronate Depot Microspheres Based on Novel Poly\(\$\epsilon\$ -caprolactone\)/Vitamin E TPGS Copolymers](#), *International Journal of Pharmaceutics: X*, **1**: 100014 (2019).
- [36] Mirzaei-Mohkam A., Garavand F., Dehnad D., Keramat J., Nasirpour A., [Optimisation, Antioxidant Attributes, Stability and Release Behaviour of Carboxymethyl Cellulose Films Incorporated with Nanoencapsulated Vitamin E](#), *Progress in Organic Coatings*, **134**: 333-341 (2019).
- [37] McClements D.J., Rao J., [Food-Grade Nanoemulsions: Formulation, Fabrication, Properties, Performance, Biological Fate, and Potential Toxicity](#), *Critical Reviews in Food Science and Nutrition*, **51**: 285-330 (2011).
- [38] Liu W., Liu W., Liu C., Liu J., Yang S., Zheng H., Lei H., Ruan R., Li T., Tu Z., Song X., [Medium-Chain Fatty Acid Nanoliposomes for Easy Energy Supply](#), *Nutrition*, **27**: 700-706 (2011).
- [39] Raikos V., [Encapsulation of vitamin E in edible orange oil-in-water emulsion beverages: Influence of heating temperature on physicochemical stability during chilled storage](#), *Food Hydrocolloids*, **72**: 155-162 (2017).
- [40] Lv S., Zhang Y., Tan H., Zhang R., McClements D. J., [Vitamin E Encapsulation within Oil-in-Water Emulsions: Impact of Emulsifier Type on Physicochemical Stability and Bioaccessibility](#), *Journal of Agricultural and Food Chemistry*, **67**: 1521-1529 (2019).
- [41] Saberi A. H., Fang Y., McClements D. J., [Fabrication Of Vitamin E-Enriched Nanoemulsions: Factors Affecting Particle Size Using Spontaneous Emulsification](#), *Journal of Colloid and Interface Science*, **391**: 95-102 (2013).
- [42] El Kinawy O. S., Petersen S., Ulrich J. [Technological Aspects of Nanoemulsion Formation of Low-Fat Foods Enriched with Vitamin E by High-Pressure Homogenization](#), *Chemical Engineering & Technology*, **35**: 937-940 (2012).