

Robust Agent Based Distribution System Restoration with Uncertainty in Loads in Smart Grids

N. Zendehtdel*, R. Asgarian Gannad Yazdi

Department of Electrical Engineering, Faculty of Engineering, Ferdowsi University of Mashhad, Mashhad, Iran

ABSTRACT

This paper presents a comprehensive robust distributed intelligent control for optimum self-healing activities in smart distribution systems considering the uncertainty in loads. The presented agent based framework obviates the requirements for a central control method and improves the reliability of the self-healing mechanism. Agents possess three characteristics including local views, decentralizations and autonomy. The message, exchanged among neighboring agents, is used to develop a global information discovery algorithm and updates the topology information of out-of-service areas, available supply capacity and routing information. Fuzzy description is employed to take into account the uncertainties of measurements in which are exchanged between agents. Moreover, to find the optimal restoration plan, incorporating the discovered data, a routing problem is developed as a fuzzy binary linear optimization problem. This problem is approached by a novel method using a specific ranking function. Finally, robustness and applicability of the proposed self-healing method is tested on two standard case studies. The obtained results emphasize that ignoring the uncertainties may lead to non-realistic solutions.

KEYWORDS: Agent based self-healing framework, Fuzzy binary linear optimization, Smart grid, Uncertain load.

1. INTRODUCTION

Smart distribution grids are distinguished from conventional distribution systems by their ability to automatically detect the fault location using the digital measurements and two-way communications, to isolate the faulted areas using the remote digital switching technologies and quickly restore as many non-faulted outage loads as possible by minimum number of switching operations. These features improve the power system reliability and service quality.

Various approaches are available for implementing self-healing control method. This includes two main categories, namely, centralized and decentralized methodologies. Different centralized restoration techniques such as mathematical

programming, knowledge-based systems and heuristic methods have been proposed to solve this problem. Mathematical programming formulates the restoration problem as a mixed integer programming problem. In [1], a two-stage algorithm has been proposed which decomposes the restoration problem into two sub-problems. In [2], an optimization technique, called differential evolution, has been used to solve distribution feeder reconfiguration and service restoration problem in a centralized way. In [3], an iterative centralized mechanism has been developed for system reconfiguration during normal operation and service restoration after single or multiple fault occurrences. In [4], optimal restoration problem is solved using a dynamic programming approach. In [5], a communication based algorithm was proposed for restoration problem to decrease the restoration time in the smart grid distribution management system.

On the other hand, heuristic techniques and

Received: 4 Jul. 2014

Revised: 10 Nov. 2014

Accepted: 29 Dec. 2014

*Corresponding author:

N. Zendehtdel (E-mail: n.zendehtdel@gmail.com)

© 2015 University of Mohaghegh Ardabili

knowledge based systems search the solution space to solve the combinatorial restoration problem. In [6], an expert system algorithm has been utilized for restoration and loss reduction of distribution systems. In [7-9], the distribution restoration problem in presence of distributed generators is modeled as nonlinear mixed integer optimization problem and solved by heuristic methods. A heuristic approach is utilized to solve the proposed problem in [7], while a modified binary particle swarm optimization was applied to solve network reconfiguration problems in [8] and a multi-objective particle swarm optimization was used in [9]. A classifying system and co-evolutionary algorithm were used in [10] for solving the problem of power delivery recovery in case of the network failure. The elaborated method uses the theoretical background of genetic-based machine learning systems and fuzzy sets theory. Moreover, artificial neural network [11], ant immune system-ant colony optimization [12], genetic algorithm [13], among other heuristic methods were also used extensively for restoration problems. Although, centralized methods obtain optimal solutions, they require low-latency communication system and large amount of data transfer. Their computing center needs expensive computational capabilities, while the accuracy of obtained results may be influenced by the uncertain behavior of loads and distributed generations in smart grids. Therefore, the centralized methods may not be practical for large smart distribution systems. Meanwhile, multi agent systems (MASs) as decentralized approaches distribute the control and intelligence in every component level of the grid using agents, to fulfill self-healing duties of smart grids.

Decentralized approaches based on the MAS technology has been investigated in the literature [14-20]. In [14], MAS architecture has been utilized for only the service restoration without considering the load shedding and priorities and obtaining of extra available capacity through load transfer in the restoration procedure. In [15, 16], MAS framework has been developed for the service restoration problem, incorporating the load shedding concept but load variation and prioritization have not been considered in these two studies. In [15], the

cooperation of agents is centrally regulated by a master agent, while in [16] each control agent individually solves a NP-hard complex combinatorial restoration problem to make restoration decisions. The grid information is entirely provided during initialization process and agents' negotiation. In [17, 18], the restoration problem has been investigated in the MAS architectures, considering load prioritization and shedding concepts. The focus of [17] is on restoring out-of-service areas using exchanged information among load agents and supply agents. Timely load variation is not considered in [17]. In [18], self-healing mechanism is studied based on Taipower distribution system rules using the knowledge based system and typical load patterns. A completely distributed algorithm has been proposed in [19] for the self-healing mechanism in distribution systems with distributed energy resources (DES). This approach takes load shedding and partial restoration into account. A decomposed agent-based self-healing control of an urban smart power grid has been proposed in [20] without considering the load prioritization. Investigating satisfaction of power system operating constraints imposes expensive centralized computation activities on the agent-based algorithm. The mentioned studies lack a control structure for self-healing mechanism in smart grids. In [21, 22], an agent based control framework has been presented for controlling the self-healing process considering the peak load in duration of the fault repair. A MAS architecture including agents with local views has been proposed in [23] to realize the self-healing mechanism.

Existing mentioned papers and similar researches on this subject in literature have not properly addressed how to design a comprehensive well-defined MAS framework which obtains an optimal control for the self-healing in smart grids incorporating the agents' decentralizations. The decision making policies in available studies are based on the learning methods or expert-based systems which often achieve near global objectives and require huge databases to restore statistical data. In spite of the available online sensor measurements in the smart grids, decision makers in the literature utilize historical data and load patterns to address the

load variation that may lead to the limited restoration of some loads.

This paper proposes a new self-healing control framework considering the agents' decentralizations, local topology information and uncertainty in measurements. The developed control algorithm is based on the MAS architecture including agents in two classes: zone and switch. Their communication policy does not impose a low latency communication on the system and decreases the dependence of algorithm on the accuracy of the data transfer. In addition, in the proposed framework, online monitored information is used to set the parameters of decision making activities and perform the distributed calculations individually to investigate the satisfaction of the power system operating constraints. Hence, the suggested method is scalable, self-adaptable and self-updatable. At the same time, to distribute the computational activities an auxiliary grid, which refers to the out-of-service areas is introduced and a new mathematical model for restoration problem in the developed auxiliary grid is developed. The identified parameters in the proposed model can be automatically generated and updated based on the online measurements incorporating their uncertainties. To guarantee the optimality and robustness of obtained switching sequence during agents' decision makings in the designed MAS architecture, a hybrid policy is developed consisting of an expert-based technique and a mathematical programming method. To this end, the uncertainty in measurements is considered using fuzzy description and a new fuzzy binary linear programming (BLP) approach is proposed to solve the presented optimization problem and find the optimal and robust restoration plan. Considering the possibility of any variation in sensor measurements during the decision making process, guarantees the robustness of the algorithm. For the sake of comparison and implementation, two smart distribution systems are selected and the proposed method is tested on them. The results demonstrate the efficacy of the proposed method as well as the robustness of the obtained self-healing plan against the load variations.

The rest of this article is organized in six sections. Section 2 indicates the structure of the proposed

distributed control framework. Section 3 explains a mathematical programming approach utilized to find a robust and optimal plan. Section 4 introduces the designed self-healing control rules to regulate the performance of agents in the proposed framework. Section 5 illustrates the results of testing the proposed control algorithm on two distribution test systems. Finally, the paper conclusions are drawn in Section 6.

2. DISTRIBUTED CONTROL FRAMEWORK

With respect to location of the Intelligent Electronic Devices (IEDs), some line segments, known as zones are formed in each distribution feeder such that some IEDs are placed on the boundaries of zones. Furthermore, considering the direction of current which passes from X side to Y side of an IED, two sides are defined for every IED. Fig. 1 shows this consideration.

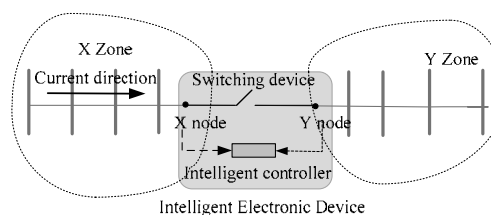

Fig. 1. X and Y sides of an intelligent electronic device

In order to propose a distributed control framework, each zone is appointed with a zone agent, which monitors local measurements and provides the fuzzy description of uncertainty. In addition, each agent-controlled switching device is assigned with a switch agent which utilizes the received measurements and cooperates with other agents to achieve self-healing mechanism. Moreover, the team concept is also defined in the MAS including the agent-controlled IEDs placed on the boundary side zone. Team concept provides the scalability of the proposed framework because if any intelligent electronic device is connected to the grid, then its IP address and operating situation can be identified for its teammates as a new agent which belongs to the team. The introduced MAS includes two types of switch agents, namely maneuvering agent which corresponds to normally opened switching device and sectionalizing agent which

corresponds to normally closed switching device. These agents move among five operating modes defined based on local measurements, when they perform actions and change the operating condition of power system. The agents' movement with their actions is shown in Fig. 2. In this figure the numbered arrows indicate the agent actions as (1) Receiving out of range measurements; (2) Fault detection; (3) Isolation; (4) Restoration. Next, five operating modes are explained.

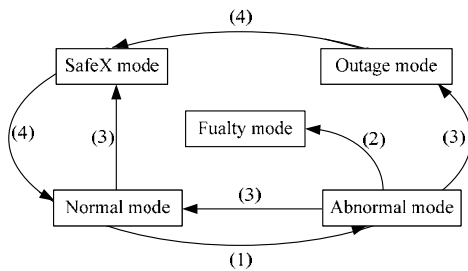

Fig. 2. The operating state transition

Abnormal mode: Large current passes from IED or an exceeding voltage drop is measured at neighbor zone.

Faulty mode: Agent has a faulted zone.

Normal mode: Neighbor zones operate normally.

Outage mode: There is a problem in both side zones.

SafeX mode: Exceeding voltage drop is measured. at Y zone

In the following, the proposed self-healing control framework including control structure, regulating rules and operating mechanism is presented regarding less of system rules or special case studies to provide the reusability and flexibility.

2.1. The agent architecture

In the MAS based control framework, the architecture of every agent as shown in Fig. 3 is composed of two layers, namely planning and operating layers.

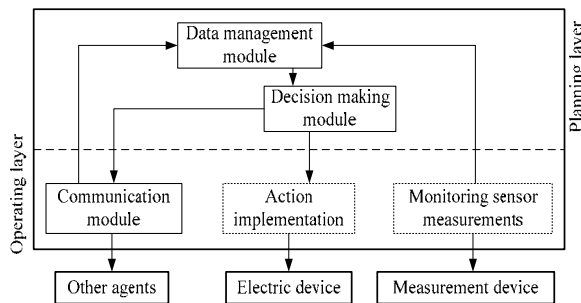

Fig. 3. The agent's architecture

The planning layer is the center of deliberation including data management, classification and decision making tasks, while the operating layer is related to the environmental perception and performance of agents containing communication based on Agent Communication Language (ACL) [24] and either monitoring measurements or action implementation. Considering agents' responsibilities, the operating layer contains different modules. The major responsibility of zone agent is monitoring measurements at their correspondent zone and sending provided information to its neighbor zone. Therefore, their operating layer is equipped with "monitoring sensor measurements" and "communication" modules. However, switch agents utilize the received information during their decision makings and carry out actions during their cooperation to heal the grid. Thus, their operating layer consists of "communication" and "action implementation" modules to give switch agents the ability of recognition and action. In addition, to this constructive difference, the functions are also defined for different modules in various levels.

2.2. Operating layer

Here, the performance of modules in operating layer is explained by the agents' type. On one hand, zone agent monitors the local measurements using the "monitoring sensor measurements" module and gives the provided uncertain description of local information to neighbor agents via "communication" module. On the other hand, various types of switch agents receive the local information from their neighbor zones and communicate with other switch agents in different levels to be aware of next zones information. Sectionalizing agents (ScAgs) continuously communicate with their *X* and *Y* teammates, while Maneuvering Agents (MvAgs) communicate with other agents of the same type without considering their positions as well as their teammates. These coordination policies decrease the dependency of the algorithm to the accurate data transfer. Hence, the obtained results are more fault tolerance against any communication failure. During the negotiation process, every switch agent updates its information using received message as:

$$\begin{aligned}
 X_i &= [ZInx_i, \Delta V_i, \Delta I_i] \\
 X_{i+1} &= [ZInx_{i+1}, \Delta V_{i+1}, \Delta I_{i+1}, \dots, X_i]
 \end{aligned}
 \tag{1}$$

Where, $ZInx_i$ denotes the i^{th} agent's neighbor zone index, ΔV_i and ΔI_i represent the calculated voltage and current differences at both sides of i^{th} zone. Moreover, switch agents affect on the power system when they carry out some actions such as closing their interfaces via "implementation action" module.

2.3. Planning layer

This layer contains two important modules which enable the agent to regulate its performance.

2.3.1. Data management module

In this module of zone agent architecture, online zone measurements including nodal voltage potential and branch current are managed and categorized separately. In switch agent architecture, the received data is classified and global information is recovered via a novel method to be used in optimal decision makings, considering the agents' local views. In this module, to discover global information about some parts of the grid some data packages are developed inspired by the link state packages which are introduced by routers in computer networks [25]. These packages consist of zones' information (i.e. zone index, operating measurements) exchanged among agents during their negotiation. Each data package starts with the neighbor zone index, and for each neighbor the voltage difference and current difference of both sides are given. In other words, this package includes data in three columns as zone index, voltage and current differences at both sides of the indexed zone. The data package rows are arranged in a particular order that points to the connectivity of zones next to agent which constructs the package. A sample of a data package constructed by $(i+1)^{th}$ agent with respect to Eq. (1) is shown in Table 1.

Table 1. Data package

The $(i+1)^{th}$ agent		
$ZInx_{i+1}$	ΔV_{i+1}	ΔI_{i+1}
$ZInx_i$	ΔV_i	ΔI_i

According to the order of rows in a data package and the zone indices presented in the first column,

the global information including connectivity of zones placed next to the agent and their operating measurements are discovered.

2.3.2. Decision making module

Zone agent calculates the voltage and current differences at both sides of the relative zone and models the available uncertainties in measurements using proper methods. Different techniques have been proposed to deal with the uncertainties in power systems which can be generally classified in two categories: possibility theory [26-28] and probabilistic techniques. The probabilistic methods itself include two categories: simulation [29, 30] and analytical [31, 32]. In [26], for consideration of load uncertainty in load, loads in buses are assumed as triangular fuzzy numbers, while in [27] the uncertainty in load is modeled as trapezoidal fuzzy number. In [28] fuzzy variables of different distributions (triangular, trapezoidal or Gaussian distributions) are applied to reflect the power demand curves, which obviously change over 24-hour. In the first category of probabilistic methods (i.e. simulation methods) Monte Carlo simulation in conjunction with genetic algorithm has been used to solve the optimal Distributed Generation (DG) placement problem in presence of uncertainties [29]. In [30], the Monte Carlo simulation has been used to analyze the optimal power flow under the uncertainty of load. However in analytical approaches a Bayesian-based method has been proposed to forecast the uncertain power production of wind and photovoltaic generators and phase load demands [31]. Discrete Time Markov Chain (DTMC) process has been utilized to model the difference between photovoltaic generations and Load [32]. In this work, the uncertainties in loads and measurements are represented by fuzzy numbers with the same membership functions such that the defuzzifier, which has the highest membership value, is equal to online measurements at a zone.

In "decision making" module of the switch agent architecture, agents' decentralization is taken into account. This module enables such agents to perform their computational activities in a distributed manner. This policy avoids the extension

of the efficacy of any agent's mistakes and provides MAS fault tolerance. Considering the switch agent types, the "decision making" module is equipped with different capabilities. For instance, ScAgs can make some comparison, simple decision makings and simple calculations using fuzzy arithmetic. These functions are regulated by expert-based rules related to following operational aspects of restoration problem. These expert-based rules utilize the operator's knowledge and experience to govern the control agents in order to achieve the self-healing objectives and guarantee the satisfaction of constraints.

- Radial topology of system should be maintained;
- The highest priority loads should be restored as soon as possible;
- The restoration is accomplished using minimum switching operations;
- Due to the radial topology of the system, the voltage drop is increased at the farthest node;
- In the radial faulted feeder, fault current flows from the substation to the lowest potential point;
- Due to the probabilistic nature of the DGs and hourly variations of the loads in the smart grids, online sensor measurements may vary during the restoration period. Hence, it is desirable to incorporate the uncertainty in the distribution system analysis.
- The online measured current difference at both sides of a zone (ΔI) points to an operational characteristic of that zone. Maximum possible voltage drop at a zone (ΔV) is calculated offline and indicates another operational characteristic of that zone.
- In order to satisfy the operational constraints during the transferring loads in restoration process, the available capacity of a backup feeder is calculated with voltage and line current limitations;
- The Allowable Additional Current (AAC) which passes feeder without any constraint violation is equal to minimum spare capacity of lines placed in the restoration path (i.e. path between the substation node and a connection node of a normally opened IED);

$$\begin{aligned} ZCur_i &= I_i^{max} - I_i \\ AAC &= \min_i \{ZCur_i\} \end{aligned} \quad (2)$$

Where $ZCur_i$ indicates the additional current which is allowed to flow from the i^{th} zone, I_i^{max} and I_i denote the i^{th} line maximum current limitation and the current value flows from i^{th} line.

- The additional Allowable Voltage Drop (AVD) at a feeder indicates its voltage capacity;

$$AVC = 0.9 - v_i^{min} \quad (3)$$

Where v_i^{min} denotes the voltage magnitude at the lowest voltage point of the restoration path.

- Regarding to the last three mentioned points, an outage zone is transferred to a backup feeder to be restored if the feeder has sufficient capacity to deal with the required operational characteristics of an outage zone;
- If a feeder has sufficient capacity, it restores outage areas as a group; otherwise these areas are divided into some sections to be restored via some feeders. The remaining outage zones should be shed;

On the other hand, in MvAg's architecture, the decision making module is equipped with hybrid control policies to find the applicable and optimal solutions during healing process. These policies are designed using mathematical programming approaches combined with the knowledge-based systems. Although the knowledge-based systems obtain a good plan for scheduling switching operations during the healing process, they suffer from shortcomings in accomplishment. They require large and static data warehouse as well as, expensive offline computational activities to be extended. Moreover, they are not self-updatable and non-adaptable.

To propose a proper and easy applicable decision making method with the distributed structure of the proposed MAS, a mathematical programming approach is used in a more simplified manner. To this end, the information of out-of-service areas are discovered from the exchanged message and a new simple optimization model is constructed based on discovered data. During decision making process, limited information related to a part of the power system is used and some computational activities are distributed among various agents using the expert-

based systems. Although, the introduced optimization model is formulated based on limited information of the power system, it gives an optimal and robust switching sequence for healing the main system.

3. MATHEMATICAL PROGRAMMING APPROACH

Mathematically, restoration problem has been modeled in the literature as a complex combinatorial optimization problem which requires the whole information of the grid to be solved in a centralized way. However, in this work a more simplified mathematical programming method is proposed as a decision making policy incorporating the agents' local views. To this end, the main grid is replaced by an auxiliary grid which is developed based on the classified information about the out-of-service areas. Then, the restoration problem in the auxiliary grid is mathematically modeled as a routing problem via a particular method. Routing problem is identified with the network topological characteristics and operational aspects of restoration. The obtained solution denotes an optimal restoration switching sequence.

3.1. Auxiliary grid construction

The auxiliary grid is a virtual grid which refers to un-faulted out-of-service areas. In the proposed distributed computing topology, the main power system is replaced by this auxiliary grid during the restoration decision making process. Constructing such grid needs some global information about out-of-service areas discovered using data packages. In this auxiliary grid, the outage zones, which their indices are presented in the first columns of the data packages, are connected together in a manner similar to package rows. Two mentioned characteristics of each zone, namely ΔV and ΔI , included in the second and third columns of data packages are considered as the representatives of zone's consumption information.

The auxiliary grid contains a capacity node connected to the grid at some zones which correspond to Y side zones of MvAgs in SafeX mode. The open/close situation of agents in the main grid identifies the connecting/disconnecting status of

the correspondent outage zones and the capacity bus in the developed grid. The required information about the connected MvAgs is discovered during the MvAgs' negotiation.

3.2. Routing problem formulation

For the sake of simplicity simplification, the restoration problem in the main grid is replaced by a constrained routing problem in the auxiliary grid. The solution of routing problem is equivalent to a restoration plan which is applicable in the main grid. The proposed routing algorithm as a multi objective optimization problem seeks to find the lowest number of paths starting from the capacity bus to connect as many outage zones as possible in the grid, considering topological constraints and operational limitations related to restoration problem. Indeed, the results obtained by routing problem denote some paths which are considered as restoration paths in power grid. In other words, the outage zones placed on the obtained path are considered to be restored by a backup feeder which its relative MvAg is connected to the capacity bus via the obtained path in the auxiliary grid.

In this routing problem, a binary variable, known as s_{ij} , is identified for the i^{th} zone to indicate the connecting situation of this zone and the capacity bus via its j^{th} output branch. This variable is introduced to see if there is a path in the auxiliary grid which starts from j^{th} output branch of capacity bus and contains the i^{th} zone without forming any ring. This variable is "1" if in the determined path, i^{th} zone is connected to capacity bus from j^{th} output branch; otherwise it is considered as "0". The proposed method considers the radial topology of the grid during the definition of binary variables.

The objective of restoration problem is restoring as many outage loads as possible using minimum switching operations. From the perspective of the proposed routing problem, this objective equals to connecting as many zones as possible in the auxiliary grid via minimum number of paths starting from capacity bus. The objective function of routing problem is defined as

$$\max_{\min_j} \sum_j \sum_i s_{ij} \quad (4)$$

The decision can be obtained by satisfying the

following constraints which are introduced based on the power system operational limitations and relative aspects of restoration problem. In the following formulations, the notation “ $\tilde{\cdot}$ ” indicates the uncertainty description of the correspondent parameters and “ \succeq ” represents the fuzzy ranking.

1- Voltage limits at the buses in the restored zone.

$$Z_j^{Rpath} \sum_i s_{ij} \Delta \tilde{I}_i + \sum_i s_{ij} \Delta \tilde{V}_i \preceq V_j^{Cn} - 0.9^{p.u.} \quad (5)$$

where, V_j^{Cn} is the voltage at a junction node of j^{th} backup feeder with the normally opened switching IED, Z_j^{Rpath} is the total impedance of restoration path from the substation to the junction node.

2- Voltage limits at buses placed in restoration path.

$$Z_j^{Rpath} \sum_i s_{ij} \Delta \tilde{I}_i - A \tilde{V} D_j \preceq 0 \quad (6)$$

where, $A \tilde{V} D_j$ represents the allowable voltage drop at the lowest voltage bus in the j^{th} backup feeder.

3- Line current limits.

$$\sum_i s_{ij} \Delta \tilde{I}_i - A \tilde{A} C_j \preceq 0 \quad (7)$$

where, $A \tilde{A} C_j$ denotes the allowable additional current passes from branches of j^{th} feeder.

4- Radial topology maintenance

An outage zone in auxiliary grid should be connected to capacity bus only via one path to not form a ring.

$$\sum_i s_{ij} - 1 \leq 0, \forall j \quad (8)$$

5- Sequence of restored zones

From the perspective of routing problem, zones are connected to a capacity bus from the closest zone to the farthest zone, considering their connection order.

$$s_{i+1j} - s_{ij} \leq 0 \quad (9)$$

6- Supply as many out-of-service zones as possible

If it is possible outage areas are supplied via lateral backup feeders.

$$\sum_i \Delta \tilde{I}_i - \sum_j \sum_i s_{ij} \Delta \tilde{I}_i \preceq 0 \quad (10)$$

The solution of this problem indicates each outage zone is re-energized by which feeder. According to the obtained solution, if some zones are still disconnected in auxiliary grid, their corresponding out-of-service areas should be shed.

3.3. Fuzzy binary linear programming

The proposed model is a fuzzy BLP problem with

fuzzy constraints including fuzzy technological coefficients as well as the right hand side numbers. To the best of our knowledge, there is no work to approach such special type of fuzzy BLP problems. In this work a proper approach is presented to solve such problems to find the optimal restoration plan.

In the proposed model, the objective function is formulated as a weighted summation of the decision variables as well as the left hand side of the constraints. In this weighted summation, if any crisp binary decision variable is obtained as “1”, its coefficient is kept in the summation; otherwise, the related coefficient is eliminated from the summation. Considering this fact, some constraints of the proposed model, satisfied by the obtained optimal solution, are formulated as the ranking operations on two fuzzy numbers. These two fuzzy numbers present at both sides of these constraints. As it clear, fuzzy arithmetic is utilized in the proposed restoration model. Therefore, some preliminaries are briefly reviewed in this section and then an approach is introduced for this special type of fuzzy BLP problem.

3.3.1. Basic definitions

Here, some preliminaries are discussed for the purpose of introducing a fuzzy BLP method.

Definition1. (Parametric form) [33]: Parametric form of a fuzzy number \tilde{z} is a pair, $(L(r), R(r))$, of functions $L(r), R(r), 0 \leq r \leq 1$, satisfying the following requirements:

1. $L(r)$ is a bounded monotonically increasing left continuous function,
2. $R(r)$ is a bounded monotonically decreasing left continuous function,
3. $L(r) \leq R(r), 0 \leq r \leq 1$.

In decision makings, fuzzy number ranking is the most usable function that compares and orders fuzzy numbers. Various ranking fuzzy number methods have been reviewed in G. Bortolan and R. Degani [34]. Most of techniques select an alternative set and compare the alternatives instead of the fuzzy sets. In [35], the magnitude of fuzzy number \tilde{z} with parametric form $\tilde{z} = (L(r), R(r))$ is defined as an alternative calculated using the following formulation,

$$\text{Mag}(\tilde{z}) = \frac{1}{2} \left(\int_0^1 (L(r) + R(r) + 2z_0) r dr \right) \quad (11)$$

As it is described in [22], the resulting scalar value of Eq. (11) is used to rank the fuzzy numbers. Indeed, the ranking of \tilde{z} and \tilde{v} is defined by magnitude function as:

1. $\text{Mag}(\tilde{z}) > \text{Mag}(\tilde{v})$ if and only if $\tilde{z} \succ \tilde{v}$.
2. $\text{Mag}(\tilde{z}) = \text{Mag}(\tilde{v})$ if and only if $\tilde{z} \approx \tilde{v}$.

3.3.2. Fuzzy BLP approach

In this work, the routing problem is modeled as a fuzzy BLP with a crisp and linear objective function as well as several linear equality and inequality constraints. Some of these constraints include the fuzzy technological coefficients as well as the right hand side numbers. They are taken into account as fuzzy number ranking operations satisfied by the optimal solution of the optimization problem. Such a fuzzy problem can be defuzzified by operating the ranking function on the problem constraints, and then the surrogate crisp model can be solved using any crisp BLP approach. Consequently, the proposed fuzzy BLP approach uses the magnitude function to rank the fuzzy numbers on the both sides of any constraint and develops an auxiliary crisp BLP which can be solved by branch-and-bound technique [36].

4. DISTRIBUTED SELF-HEALING CONTROL FRAMEWORK

In the presented MAS, due to the fuzzy description of uncertainty in measurements, switch agents conduct some distributed computational activities to evaluate their situation using the arithmetic and ordering operations on fuzzy numbers. Furthermore, enough rules are developed to provide a feasible sequence of switching operations to guarantee the applicability of the given self-healing plan. The requirements of the decision making process such as power system operating constraints and restoration objectives are entirely considered with the expert-based knowledge.

4.1. Distributed calculation

Switch agents carry out some distributed calculations to determine the available capacity of backup feeders and discover the information of out-of-

service areas using the following rules.

Rule1: When a ScAg in normal mode is asked about the available capacity of its related feeder, it forwards this message to its X teammates unless it belongs to the substation team.

Rule2: ScAg in substation team replies the capacity query with a message including the total transmission line impedance, the lowest bus voltage and the lowest value of spare current capacity of lines at its X zone.

Rule3: ScAg in normal mode determines some parameters and replies the capacity query after receiving the replication of its X teammates. ScAg calculates the Thevenin impedance related to path between substation and its X zone. It uses the impedance of its X zone lines and received impedance from its X teammates. It determines the lowest value among spare current capacity of lines at its X zone and the minimum current received from its X teammates related to the next zone. The lowest value among bus voltages at its X zone and the received minimum voltage is also calculated. This agent sends these parameters to its Y teammates.

Rule4: If MvAg in SafeX mode receives the replication of its X teammates, which are in normal mode, it repeats the distributed calculations mentioned in Rule3 to determine the allowable voltage drop and additional current of its correspondent backup feeder.

Rule5: If ScAg in Outage mode is asked about its Y zone requirements, it forwards the message to its Y teammates unless it belongs to the end or faulty team.

Rule6: ScAg in Outage mode replies the consumption query after attaching the information about its Y zone including the zone index, its $\Delta\tilde{V}$ and $\Delta\tilde{I}$ to the received message.

4.2. Fault location detection

The efficacy of a permanent fault is appeared only in the faulted feeder in a radial topology of a distribution system. Considering this fact, in the proposed MAS fault is localized by agents using following rules:

Rule1: If ScAg moves into the abnormal mode, it queries current measurements at its next zone by sending out "QUERY_IF" to its Y teammates.

Rule2: ScAg in abnormal mode replies the query with “INFORM True” if it measures exceeding current; otherwise it sends “INFORM False”.

Rule3: If ScAg in abnormal mode only receives “False” it localizes the fault in its Y side zone.

4.3. Fault isolation

After detecting the fault location, the smallest possible area is isolated by agents using the following rules.

Rule1: ScAg in abnormal mode, who localizes the fault, opens its interface and moves into Faulty mode. It wants its Y teammates to perform similar actions.

Rule2: The interfaces of ScAgs in Faulty mode are allowed to be closed only if fault is repaired.

Rule3: Switch agents, who receive an extended loss of voltage from their neighbor zone agents open their interfaces and move into Outage mode.

The overall procedure of fault location detection and restoration is shown in Fig. 4.

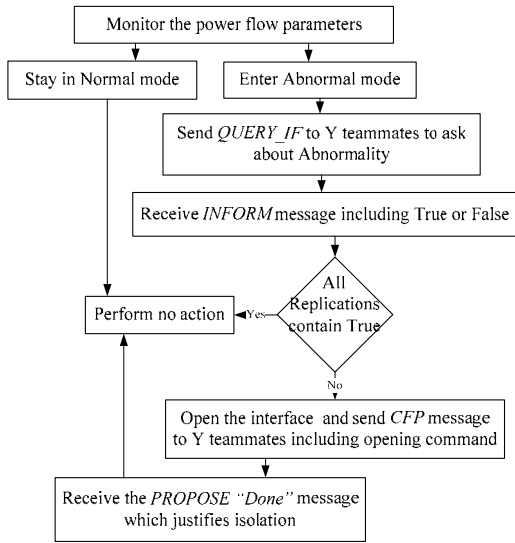

Fig. 4. Overall procedure of agents' operation to detect the fault location and isolate it

4.4. Priority load restoration

Regarding to the limited supply capacity, if the highest priority loads such as hospitals or big industrial centers place at a zone, that zone is considered as a highest priority zone for restoration.

Switch agents correspond to IEDs placed on the

boundary of the priority zone are considered as high priority agents: High priority Sectionalizing Agents (HScAg) and High priority Maneuvering Agents (HMvAg). These high priority switch agents are responsible to find the best restoration path to reenergized high priority loads as soon as possible. They use the following policies.

Rule1: HScAg in Outage mode declares its request about re-energizing its neighbor zone by sending out “REQUEST” message containing the index of priority zone, its $\Delta\tilde{V}$ and $\Delta\tilde{I}$.

Rule2: If HScAg in Outage mode receives “CONFIRM close interface” from its X teammates, it closes its interface and moves into the normal mode.

Rule3: HMvAg in SafeX mode with maximum capacity has high priority to restore priority loads.

In addition, non-priority agents coordinate together using following rules:

Rule1: ScAgs in outage mode attaches the information of its Y zone to “REQUEST” message and forwards it to its X teammates.

Rule2: ScAg in outage mode closes its interface and forwards “CONFIRM” message.

Rule3: MvAg in SafeX mode considers its correspondent feeder. In addition, this agent utilizes data packages including information about outage zones placed in the priority path, to evaluate the possibility of restoration incorporating Eqs. (5) to (7). From the topological perspective, the path between MvAg and priority zone is known as priority-path. Rule4: MvAg in SafeX mode queries MnAgs' capacity by sending “QUERY_IF”, if Eqs. (5) to (7) are satisfied; otherwise, it determines its capacity as zero.

Rule5: MvAg in SafeX mode replies the capacity queries with “INFORM” message including its non-zero capacity; otherwise it replies with “REFUSE”.

Rule6: MvAg in SafeX mode with enough and maximum capacity closes its interface as a main maneuvering agent and sends out “CONFIRM” message to other ScAgs in Outage mode placed in priority-path to give them closing order.

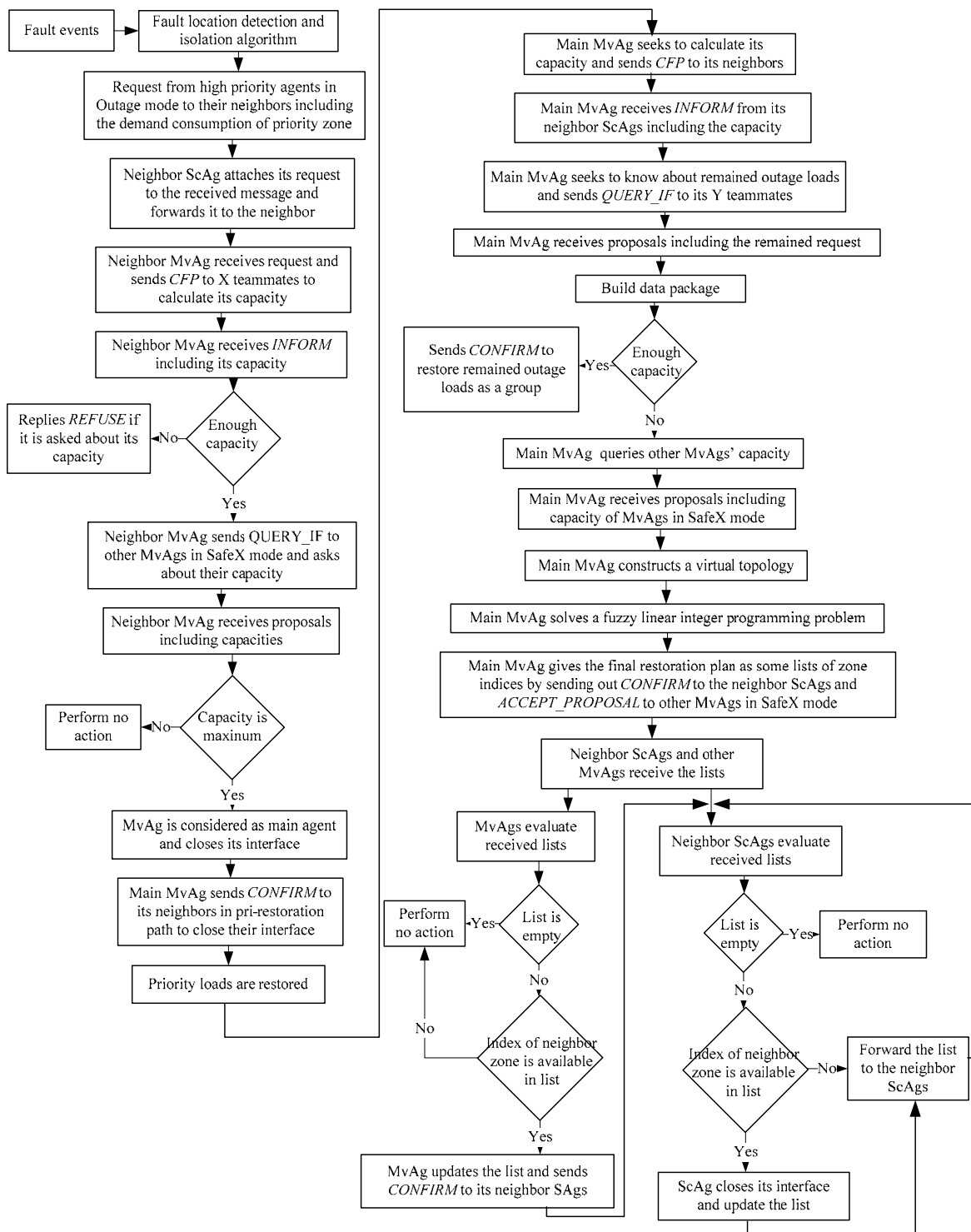

Fig. 5. Overall procedure of restoration phase using the proposed control agents

4.5. Non-priority load restoration

After restoring priority loads, the control switch agents cooperate together based on the following rules to restore as many remaining outage loads as possible.

Rule1: Main agent in normal mode updates its

knowledge about its available capacity and the demand consumption of remaining outage zones.

Rule2: Main agent seeks to find the restoration plan with the performance of its decision making module.

Rule3: Main agent gives the founded plan as a list

of outage zone indices to MvAg in SafeX mode by sending “ACCEPT_PROPOSAL” message.

Rule4: Main agent sends “CONFIRM” message to its *Y* teammates and gives them a list of outage zone indices which should be restored by the main agent.

Rule5: ScAgs in Normal mode placed in priority-path forward the “CONFIRM” message.

Rule6: ScAgs in SafeX mode asks its *Y* teammates about the requirements of their *Y* side zones.

Rule7: ScAgs in SafeX mode forward the “CONFIRM” message to its *Y* teammates.

Rule8: ScAgs in Outage mode repeats rules 5 and 6 of subsection 4.1.

Rule9: ScAg in Outage mode closes its interface if it finds its *Y* zone index in the received list.

Rule10: MvAgs in SafeX mode close their

interfaces if the received restoration plan is not empty.

Rule11: MvAgs in SafeX mode forwards the restoration plan to its *Y* teammates.

Rule10: MvAgs in SafeX mode close their interfaces if the received restoration plan is not empty.

Rule11: MvAgs in SafeX mode forwards the restoration plan to its *Y* teammates via a message.

Considering the mentioned rules, the overall procedure of agents’ operating in the restoration phase of algorithm is shown in Fig. 5. As can be seen, the restoration phase is started by re-energizing the highest priority loads and then other outage loads are allowed to be restored. Furthermore, for clarification, the relationship between agents and their cooperation during the healing process is shown in Fig. 6.

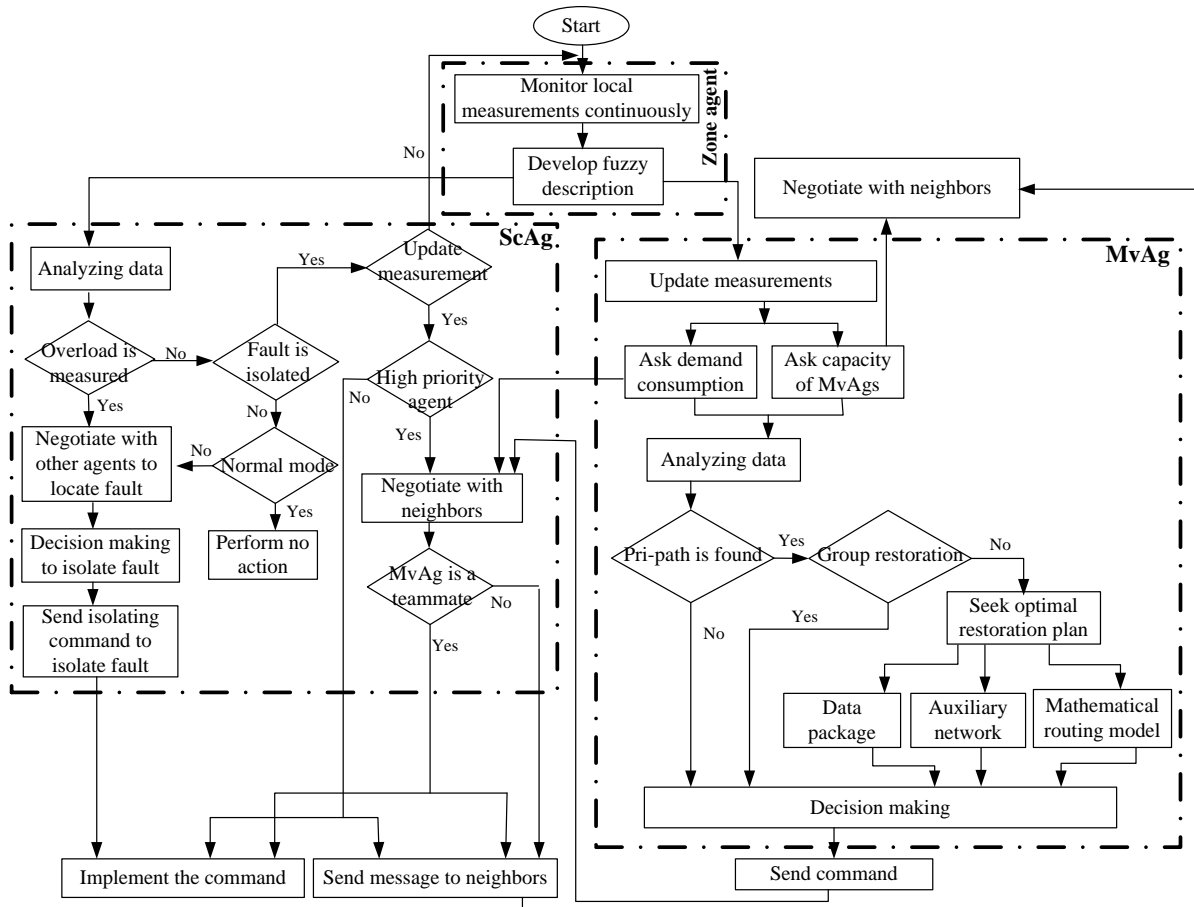

Fig. 6. The relationship among agents and their cooperation

As can be seen from Fig. 6, sectionalizing agents receive the measurements provided by neighbor zone agents and evaluate them to localize and isolate

the fault. They cooperate with other switch agent types by sending data to them and implementing the received commands. On the other hand, manu-

vering agents classify the received network information and develop a mathematical optimization for decision making problem using the managed data. According to the performance of agents and their cooperation, a whole pseudo-code for program of each agent is provided in appendix.

5. CASE STUDY

To validate the proposed robust self-healing MAS control algorithm, two distribution test systems including 70-nodes, 4-feeder [37] and IEEE 33-node [38] are selected as a case studies. It is assumed, the main distribution feeder has enough capacity to supply loads in normal operating condition. In this study, the distribution system is modeled using MATLAB simulator as a pilot system and the iterative simulation gives the online information as sensor measurements. Furthermore, the agents' coordination and communication services are provided in Java Agent Development Framework (JADE). Microsoft Excel is used as an interface to exchange information between Matlab and JADE platforms.

5.1. Case1. 70-node, 4-feeder distribution system

The proposed method is tested on a sample distribution system including two substations, 70 nodes and four feeders [37] as shown in Fig. 7 with zone numbers. In this system, feeders 1 and 2 are residential feeders, feeder 3 is an industrial feeder and feeder 4 is a commercial feeder. It is assumed that fault occurs in zone 1 at feeder 4 in duration of load growth and zone 10 contains large industrial loads which are considered as high priority loads for restoration. The uncertainty in loads is described as triangular fuzzy numbers shown in Fig. 8. Other shapes for fuzzy numbers based on operator insight or gathered information can also be used. Minimum load and maximum bus loads are 95% and 120% of the load with the highest membership value, respectively. With this assumption, the voltage and current differences at the both sides of a zone, branch current and also loading capacity of a backup feeder are considered as triangular fuzzy numbers with the same membership functions.

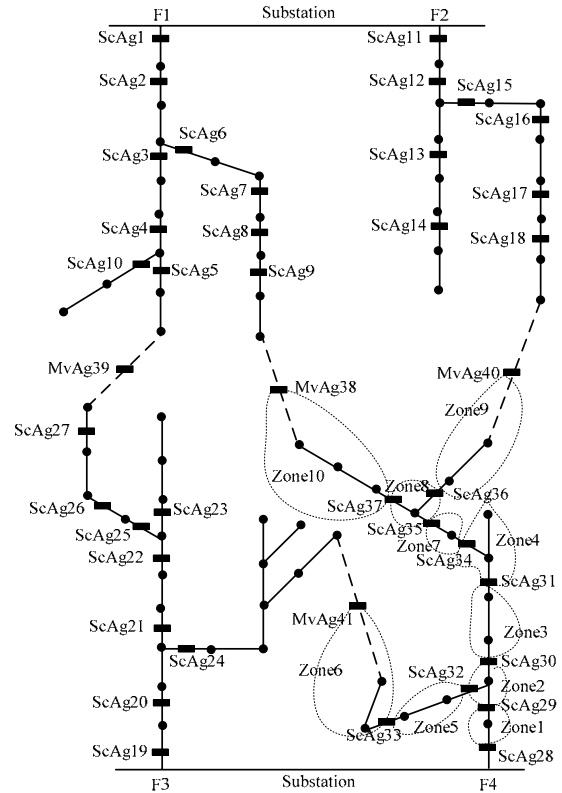

Fig. 7. The 70-node, 4-feeder test system

Zone agent creates these fuzzy descriptions by placing the sensor measurements at the center of fuzzy numbers with the highest membership degree. The measurements are monitored from the pilot system in the pre-fault condition. According to the possibility of load variation two separated periods are defined based on the load consumption, which are the lightest loading period (i.e. from 1 AM to 6 AM) and the highest loading period (i.e. from 5 PM to 10 PM). The proposed control method is tested on the mentioned distribution system in two scenarios considering these two periods and the fuzzy description of uncertainties in online measurements. The obtained switching sequences in each scenario are compared with the restoration plan presented in [21] to show the capability of the proposed method.

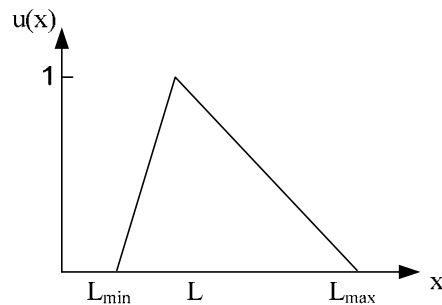

Fig. 8. Load as a triangular fuzzy number

5.1.1. Scenario 1

The fault current passes through switch 28 in the lightest loading period, and thus ScAg 28 concludes its situation is in the abnormal mode. It negotiates with its *Y* teammate, known as ScAg 29, to query about its operating situation. Fig. 9 illustrates the switch agents' negotiation during their cooperation to localize and isolate the fault. The fault is isolated by opening switches 28 and 29. After that, ScAgs 30 to 37 open their interfaces due to the extended loss of voltage and enter the outage mode. HScAg 37 in outage mode seeks a capable backup feeder to restore highest priority loads as soon as possible, so it sends the information of zone 10 to its teammates. MvAg 41 with the highest and enough supply capacity is selected as the main agent to close its interface and restore zone 10 considering the satisfaction of operating constraints modeled as Eqs. (5) to (7). This main agent sends a closing order to its *Y* teammate to be implemented and forwarded to other parts in restoration path. Now, MvAg 41 in normal mode starts negotiation to repeat the computation activities which obtain the new capacity of its correspondent feeder and the requirements of remaining outage zones to investigate the possibility of the group restoration.

In this case, due to satisfaction of Eqs. (5) to (7), MvAg concludes to implement the group restoration, and therefore it requests its *Y* teammates to close their interfaces. The "CONFIRM" message is forwarded and the ScAgs close their interfaces to restore outage areas. The obtained healing switching sequence is shown in Table 2. In this case study, the proposed method achieves the same healing plan in comparison with [21], while it presents fully distributed robust control framework including agents with local views. The proposed control algorithm uses the online sensor measurements and considers the possibility of their timely variations as uncertainty to provide enough robustness. In addition to using expert-based systems, it utilizes the mathematical programming to guarantee the optimality of obtained results and reduce the requirements to the expensive pre-computations, historical data and huge data bases which are necessary in [21].

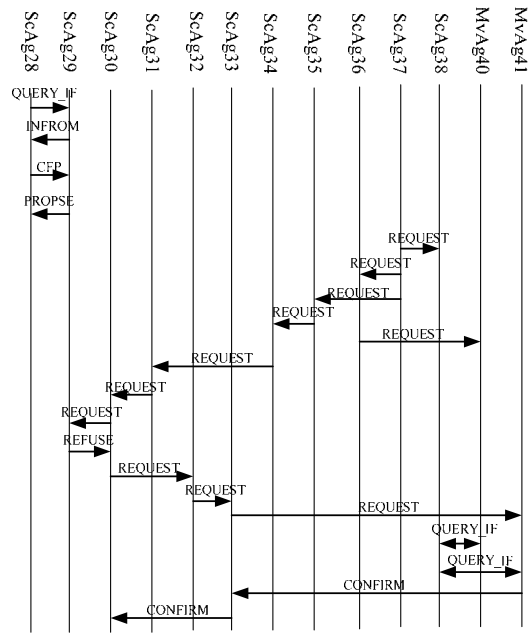

Fig. 9. The shortened list of exchanged message

5.1.2. Scenario 2

Here, it is assumed that fault occurs in highest loading period. Agents cooperate with each other in the same way as described in scenario 1 to locate and isolate the fault. The downstream agents also open their interfaces and move into the outage mode. HScAg 37 in outage mode seeks to find a backup feeder and sends its request to its teammates. MvAgs 38, 40 and 41 negotiate to its *X* teammates to calculate their available capacity after receiving the request of HScAg 37. Furthermore, these three MvAgs negotiate together and exchange information about their capacities. Consequently, MvAg 38 closes its interface as a main agent and restores zone 10. It repeats its distributed calculations explained in section 4.1 to investigate how remaining outage areas can be restored. Due to the lack of capacity for restoring whole of the outage loads via feeder F1, the main agent asks other MvAgs about their capacities. Moreover, it creates data packages to discover the global information about the outage areas.

MvAg 38 constructs an auxiliary grid shown in Fig. 10 and constructs the mathematical routing model for restoration problem in auxiliary grid as explained in section 4.

The solution of the mathematical programming problem gives the optimal paths in the auxiliary grid such that each path connects some zones in the

network to the capacity node.

Table 2. The healing plan using switching operations

Step	ScAg28	ScAg29	ScAg30	ScAg31	ScAg32	ScAg33	ScAg34	ScAg35	ScAg36	ScAg37	MvAg38	MvAg40	MvAg41
I	0	0	1	1	1	1	1	1	1	1	0	0	0
II	0	0	0	0	0	0	0	0	0	0	0	0	0
III	0	0	1	1	1	1	1	1	0	1	0	0	1
IV	0	0	1	1	1	1	1	1	1	1	0	0	1

I. Isolation, II. Extended loss of voltage at downstream nodes, III. Priority load restoration, IV. Non-priority load restoration.

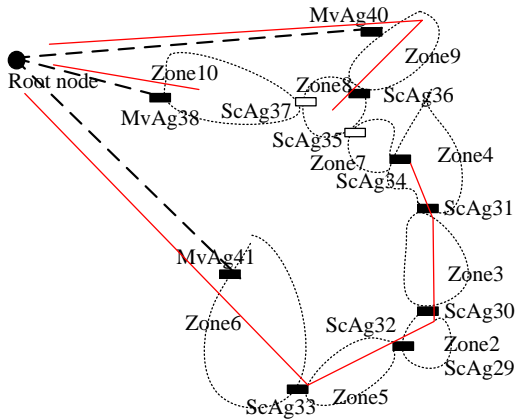

Fig. 10. The auxiliary grid

Considering the auxiliary grid and the obtained paths, shown in Fig. 10 by red lines, the optimal healing plan divides outage loads into separated groups such that each one is restored via a backup feeder. The switching sequences during the self-healing mechanism are illustrated in Fig. 11. The healing mechanism is divided into some sub-process such as I. Fault detection, II. Fault isolation, III. Extended loss of voltage, IV. Highest priority load restoration, V. Restoring non-priority outage loads via the main agent and VI. Complete the restoration process.

Comparing with [21], a similar switching sequence is obtained by the proposed control framework such that it utilizes three backup feeders to restore out-of-service areas in three separated groups using similar numbers of switching operations. This fact emphasizes the capability of the proposed method.

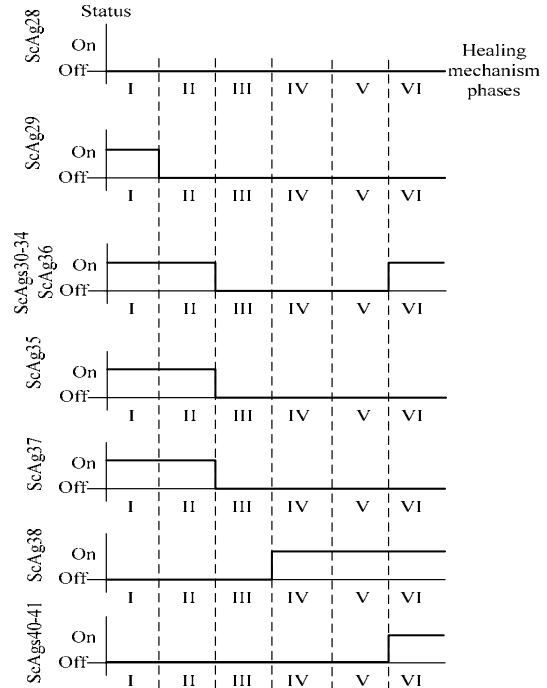

Fig. 11. The switching operations

5.2. Case 2. IEEE 33-node standard test system

The IEEE 33-node radial distribution test system includes 33 buses and 32 branches [38]. The 12.66 kV sub-station is located at node 1. All calculations are carried out in the p.u. system with 12.66 kV and 100 MVA as base voltage and power quantities, respectively. Considering the location of intelligent switching devices, 18 agent-controlled switching devices, including five MvAgs and 13 ScAgs, are added. Fig. 12 presents system with its zones and teams. According to the position of the intelligent switching devices, 13 teams are formed and 13 zone agents, ZAGs, are defined to monitor the measurements and present the fuzzy description of the available uncertainties. In the test system, the team 6 load is critical while others are not. A permanent balanced fault is considered at node 7, zone 3.

A comparison between two various scenarios is presented to demonstrate the robustness of the proposed self-healing plan in presence of the load uncertainties.

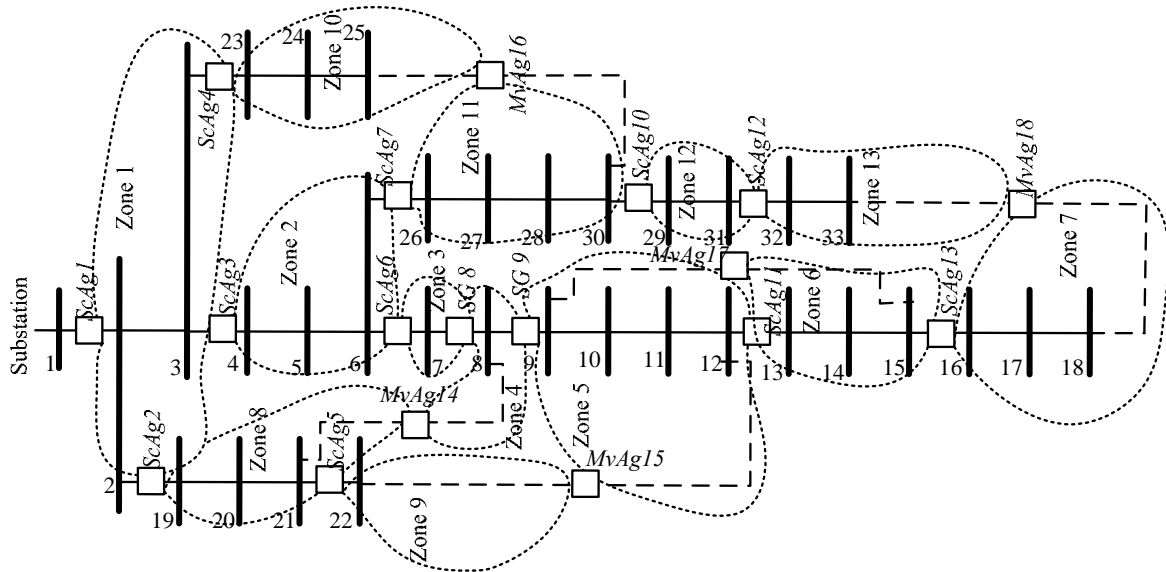

Fig 12. IEEE 33-node test system.

In the first scenario, the proposed method is implemented on the distribution system with the uncertain loads. The obtained results illustrate the capability of the proposed MAS architecture to control the self-healing process. The consideration of the uncertainties in the loads increases the robustness, reliability and applicability of the obtained self-healing plan. To demonstrate this fact, the viewpoint of the proposed MAS is deliberately changed in the second scenario and the responsibility of ZAgS is modified.

ZAgS monitor the pre-fault measurements and ignore the possibility of the load variations during the repair process of the faulted area. The agents in the modified MAS structure cooperate together with respect to measurements monitored by ZAgS, and obtain a new self-healing plan. The comparison between these two obtained self-healing plans demonstrates the robustness of the proposed method and shows the importance of the consideration of the load variations in decision makings. The results emphasize that disregarding the uncertainties may lead to a non-realistic self-healing policy.

5.2.1. Scenario 1. Consideration of uncertainty in loads

In this scenario, the time variation of loads in a smart distribution system and the uncertainty in the measurements are considered to increase the flexibility of the self-healing process and guarantee

the applicability of the resulting switching plan. In this case the description of uncertainty is the same as case 1. With this assumption, the voltage difference and current difference on the both sides of each zone, branch current and also loading capacity of backup feeder are considered as triangular fuzzy numbers with the same membership functions. ZAgS are responsible to create these fuzzy descriptions, while, other agents carry out their tasks using this provided data during the various phases of the proposed method. The proposed approach controls the self-healing method using the switching device operations. The obtained sequence of the switching operations during the healing process is illustrated in Table 3.

As can be seen in Table 3, the given restoration policy divides the outage zones into two groups and utilizes two switching operations. Although this policy is more costly than a single-group restoration plan, the effectiveness of the obtained plan is guaranteed against the load variations during the faulted area repair time.

In this case, a permanent fault occurs at node 7 and the simulation ends while the MvAg 18 closes its interface and re-energizes the disconnected zone 7. To show the effectiveness of the proposed control framework, Table 4 illustrates the variations of the voltage magnitude of bus 14 as a critical node at zone 6.

Table 3. Switching sequences in scenario 1

Step	ScAg1	ScAg2	ScAg3	ScAg4	ScAg5	ScAg6	ScAg7	ScAg8	ScAg9	ScAg10	ScAg11	ScAg12	ScAg13	MvAg14	MvAg15	MvAg16	MvAg17	MvAg18
Pre-Fault																		
	1	1	1	1	1	1	1	1	1	1	1	1	1	0	0	0	0	0
Post-Fault																		
I	1	1	1	1	1	0	1	1	1	1	1	1	1	0	0	0	0	0
	1	1	1	1	1	0	1	0	1	1	1	1	0	0	0	0	0	0
II	1	1	1	1	1	0	1	0	0	1	0	1	0	0	0	0	0	0
III	1	1	1	1	1	0	1	0	0	1	0	1	0	1	0	0	0	0
	1	1	1	1	1	0	1	0	1	1	0	1	0	1	0	0	0	0
	1	1	1	1	1	0	1	0	1	1	1	1	0	1	0	0	0	0
IV	1	1	1	1	1	0	1	0	1	1	1	1	0	1	0	0	0	1

I. Isolation, II. Extended loss of voltage at downstream nodes, III. Priority load restoration, IV. Non-priority load restoration

As can be seen that, the voltage magnitude returns to its normal range and stays within this range after restoring the loads placed in pre-restoration path.

Table 4. Voltage magnitude of node14

Voltage (p.u.)	0.9205	0.0001	0.9644	0.9643
Self-healing phase	Pre-fault	Isolation	Priority load restoration	Complete restoration

5.2.2. Disregarding of uncertainty

In this scenario, consideration of the load uncertainties by the zone agents is ignored. In other words, ZAGs monitor the on-line measurements and provide them to the agents placed on the boundary of the relative zone. Indeed, the ZAGs ignore the possibility of the load variation during the fault repair time. According to this modification, switching device agents cooperate together to obtain a self-healing plan.

In this scenario, the performance of the agents is similar to the first scenario, except for when the non-priority out-of-service loads are allowed to be restored. In this part of the MAS algorithm, MvAg14 as a main manoeuvring agent updates its knowledge about the requirements of remaining disconnected loads and the available capacity by negotiating with its teammates, and investigates the possibility of the group restoration. Considering the satisfaction of Eqs. (5) to (7), the MvAg 14 concludes to restore the remaining disconnected outage loads as a single group and sends a closing command to its teammates asks other agents in

restoration path to close their interfaces to complete the restoration process.

The sequence of the switching operations during the self-healing process is shown in Table. 4. As can be seen that, the modified MAS algorithm obtains a self-healing plan which restores loads as a single group. However, the accuracy and applicability of this plan in presence of the load variations, as an unavoidable concept of power systems, should be examined.

5.2.3. Robustness of the Proposed Method

In the real world, the probabilistic nature of the DGs and time varying loads lead to the uncertain behavior of the smart grids. Therefore, disregarding the uncertainty during the self-healing decision making may cause a non-realistic plan which is not implementable in real smart grids. To illustrate this fact, in this section the simulation conducted in the first scenario is repeated using the self-healing plan obtained in the second scenario to restore the out-of-service areas in the smart distribution system with the uncertain and time varying loads. Table 5 includes the on-line branch currents in the backup feeder after applying the policy.

As can be seen that in Table 5, group restoration causes backup feeder overloading in the distribution system with uncertain loads. The current magnitudes of the “line1” and “line18” violate their limitations when the switching sequence developed in the second scenario, is applied to the system with the uncertain in loads. Indeed, controlling the self-healing mechanism without the consideration of the

uncertainty is not robust enough and may violate the operational constraints. It emphasizes that, considering the uncertainty in the measurements increases the reliability and guarantees the applicability of switching policy in healing process.

Table 5. Current magnitude of some lines

Line Num.	Zone	Cur. Mag. (Amp)	Max. Allowable Cur. (Amp)
Line1	Zone1	512.14	500
Line2		330.43	500
Line18		168.23	142
Line19	Zone8	155.55	200
Line20		143.11	200
Line21		12.37	200
Line8	Zone4	90.41	400
Line9	Zone5	82.50	200
Line10		74.66	200
Line11		68.24	200
Line12		59.88	200
Line13	Zone6	51.58	200
Line14		34.97	200
Line15		27.50	200
Line16	Zone7	19.71	200
Line17		11.95	200

6. CONCLUSION

A distributed comprehensive framework is introduced for implementing optimum and robust self-healing control activities in smart distribution systems with uncertain in loads. The contributions of this control algorithm are (1) Building a fully distributed architecture which considers agents with local views, decentralizations and limited communication; (2) Designing a control method which is self-updatable automatically using continues online measurements; (3) Designing a global information discovery algorithm using a proper data classification; (4) Proposing a routing problem as a simplified mathematical optimization method for restoration problem to guarantee the optimality of the obtained restoration plan; (5) Considering the possibility of load variation during the restoration period using fuzzy description of uncertain measurements to guarantee the robustness. The obtained results of testing the proposed

algorithm on two standard test systems verify the applicability of the proposed method.

APPENDIX

In this section, pseudo-code for programming each type of agents is provided with its special responsibilities. Fig. 13 illustrates pseudo-code for programming zone agents. Given various capabilities of each class of switch agents, the relative pseudo-code is developed incorporating agents' operating situations. The pseudo-codes for programming sectionalizing and maneuvering agents are shown in Figs. 14 and 15 respectively.

```

Initialize voltage to zero;
Initialize line current to zero;
Initialize maximum limit of current;
Initialize line impedance to zero;
Initialize delta-v to zero;
Initialize delta-i to zero;
Repeat
    Initialize counter to zero;
    Input the voltage, line current, impedance;
    Compute the minimum spar capacity of lines;
    Compute minimum voltage;
    Set the delta-v to the calculated voltage difference at both side of zone;
    Set the delta-i to the calculated current difference at both side of zone;
    Generate the fuzzy description of measured data;
    Compute the total impedance of lines at zone;
    Send the determined parameters to the neighbors via a message;
    Repeat
        Increment counter;
    Until counter reaches to its limit;
Until the self-healing mechanism is completed;
    
```

Fig 13. Pseudo-code for programming zone agents

```

Initialize the AgCnt to zero;
Initialize the MgCnt to zero;
Receive the uncertainty description of measurements;
Determine the operating situation;
If operating mode is Abnormal
    Set step to zero;
    Switch(step){
        Case 0:
            Send QUERY_IF' to its Y teammates to ask their situation;
            Repeat
                Increment AgCnt;
            Until the message sent to all the teammates;
    
```

```

Increment step;
Break;
Case 1:
Repeat
    Receive a replication;
    Investigate the content of message;
    Increment MgCnt;
Until MgCnt is equal to AgCnt;
Increment step;
Break;
Case 2:
If all messages include "False"
    Fault is localized at Y side zone;
    Opening the interface;
    Entering the Faulton mode;
    Sending opening command to its Y teammates;
Elseif receive opening command
    Opening the interface;
    Entering the Faulton mode;
    Forward confirm message to ensure the accurate
    procedure;
Endif
Increment step;
Break;}
If voltage drop is extended
    Open the interface;
    Enter the outage mode;
Endif;
Elseif operating mode is Normal
If agent is asked about the available capacity;
If belongs to substation team;
    Compute the spar current capacity at X side zone;
    Compute allowable voltage drop at X side zone;
    Send calculated parameters to the Y teammates;
Else
    Forward the message to its X teammates;
Endif;
Endif;
If agent receives a replication from its X teammates
    Compute the spar current capacity at X side zone;
    Compute the allowable voltage drop at X side zone;
    Compute minimum value between received and
    calculated current capacity;
    Compute minimum value between received and
    calculated allowable voltage drop;
    Send the calculated values to Y teammates;
Endif;
If agent receives ordering command
    Implement the command or forward it;
Endif;
Elseif operating mode is Outage
If agent is a high priority agent
    It sends the request message including the
    requirements of the high priority zone to its
    teammates;
Endif;
If agent is asked about the demand consumption of
outage zone
    If agent is in Faulton mode

```

```

    It replies with REFUSE message and does not
    perform any action;
Elseif
    If agent belongs to the end zone or receives
    REFUSE replication
        It replies by sending the information about the
        neighbor zone;
    Else
        It forwards the message;
    If it receives the replication of their teammates
        It attaches the information of the neighbor zone to
        the received message;
        It replies by sending the provided attachments;
    Endif;
Endif ;
Endif;
Endif;
If agent receives the request of high priority agent
Repeat
    It sums its neighbor zone requirements with the
    content of received message;
    It forward provided information to its teammates;
Until the message received by an agent in Faulton
mode;
Endif;
If agent receives a closing order
    It closes its interface;
    It forwards the received ordering message;
Endif
If agent receives a list of zone indices
    Processing the received list;
    If the index of the outage neighbor zone is available in
    the list
        Closing the interface;
        Eliminating the zone index from the list;
        Forwarding the list to the teammates;
    Else
        Performing nothing;
    Endif;
Endif;
Elseif operating mode is SafeX
    If agent is asked about the remaining outage zones'
    demand
        It sends a CFP to Y teammates and asks them about
        their requirements;
        It waits to receive the answer to calculate the sum of
        voltage differences at both sides of outage zones;
        It forwards the calculated information back;
    Endif;
Elseif operating mode is Faulton
    Agent does not perform any action;
Endif ;
Endif;

```

Fig 14. Pseudo-code for sectionalizing agents

```

Initialize MvAg-Cnt to zero;
Receive the uncertainty description of measurements;
Determine the operating situation;
If operating situation is not SafeX mode
    Agent does not perform any action;
Else
    If agent receives the request of priority zone
        It sends a CFP message to its X teammates and asks
        them about the capacity;
        If it receives the replication from its X teammates
            It investigates the available capacity to see if it is
            sufficient for restoring the highest priority loads
            and the outage zones placed in the path (using (5)
            to (7));
        If the capacity is enough
            It asks other maneuvering agents about their
            capacity;
            It waits to receive replications;
            Repeat
                Receiving maneuvering agent replication;
                Increment MvAg-Cnt;
            Until MvAg-Cnt equals to the numbers of
            maneuvering agent minus one
            Processing the received capacities to find out
            maximum value;
            If agent has the highest capacity
                It closes its interface and enters to the Normal
                mode;
                It is considered as main maneuvering agent
                It sends the closing command to its Y teammates
                which gives the request message
            Else
                It does not perform any action
            Endif
        Else
            Set its capacity to zero
        Endif
    Endif
Endif
If agent is asked about its capacity
    It sends a CFP message to its X teammates and asks
    them about the capacity
    If it receives the replication from its X teammates
        It replies with sending its available capacity
    Endif
Endif
If agent receives a list of zone indices from the main
agent
    If the list is not empty
        Closing the interface
        Sending the message to its Y teammates including
        the list
    Else
        Performing no action
    Endif
Endif
If agent is assigned as main agent
    It sends a message to its Y teammates to ask them
    about the requirements of remaining outage zones
    
```

```

It sends a message to its X teammates to update its
knowledge about the capacity of correspondent
backup feeder
It waits to receive replications
If it receives replication
    Generating data packages
    Generating auxiliary grid
    Generating the rooting optimization problem
    Computing the solution of the rooting optimization
    problem using fuzzy BLP approach
Endif
Generating lists of zone indices by dividing given
solution into some categories such that each one
related to a maneuvering agent
Sending the relative list of zone indices to another
maneuvering agent
If a list assign to it, is not empty
    Sending CONFIRM message including the list to its
    Y teammates
Else
    Performing no action
Endif
Endif
    
```

Fig 15. Pseudo-code for maneuvering agents

REFERENCES

- [1] T. Nagata, S. Hatakeyama, M. Yasouka and H. Sasaki, "An efficient method for power distribution system restoration based on mathematical programming and operation strategy," *Proceedings of the International Conference of Power System Technology*, Perth, WA, pp. 1545-1550, 2000.
- [2] D. Pal, S. Kumar, B. Tudu, K.K. Mandal and N. Chakraborty, "Efficient and automatic reconfiguration and service restoration in radial distribution system using differential evolution," *Proceedings of the International Conference on Frontiers of Intelligent Computing: Theory and Applications Advances in Intelligent Systems and Computing*, vol. 199, pp. 365-372, 2013.
- [3] T. Ananthapadmanabha, R. Prakash, M. Kumar Pujar, A. Gangadhara and M. Gangadhara, "System reconfiguration and service restoration of primary distribution systems augmented by capacitors using a new level-wise approach," *Journal of Electrical and Electronics Engineering Research*, vol. 3, no. 3, pp. 42-51, 2011.
- [4] R. Perez-Guerrero, G. Heydt, N. Jack, B. Keel, and A. Castelhana, "Optimal restoration of distribution systems using dynamic programming," *IEEE Transactions on Power Delivery*, vol. 23, no. 3, pp. 1589-1596, 2008.

- [5] A. Hussain, M.-S. Choi and S.-J. Lee "A novel algorithm for reducing restoration time in smart distribution systems utilizing reclosing dead time," *Journal of Electrical Engineering & Technology*, vol. 9, pp. 742-748, 2014.
- [6] C.-C. Liu, S. Lee, and S. Venkata, "An expert system operational aid for restoration and loss reduction of distribution systems," *IEEE Transactions on Power Systems*, vol. 3, no. 2, pp. 619-626, 1988.
- [7] W.P. Mathias-Neto "Distribution system restoration in a DG environment using a heuristic constructive multi-start algorithm," *Proceedings of the IEEE/PES Transmission and Distribution Conference and Exposition*, Sao Paulo, pp. 86-91, 2010.
- [8] Y. Shi, S. Yao and Y. Wang, "Research on distribution system restoration considering distributed generation," *Proceedings of the China International Conference on Electricity Distribution*, pp. 1-5, 2010.
- [9] A. Arya, Y. Kumar and M. Dubey, "Reconfiguration of Electric Distribution Network Using Modified Particle Swarm Optimization," *International Journal of Computer Applications*, vol. 34, no. 6, pp. 54-62, 2011.
- [10] J. Stepien and S. Filipiak, "Evolutionary approach to restoration service of electric power distribution networks," *American Journal of Engineering Research*, vol. 2, no. 6, pp. 94-102, 2013.
- [11] Y. Hsu and H. Huang, "Distribution system service restoration using the artificial neural network approach and pattern recognition method," *IEE Proceedings on Generation, Transmission, Distribution*, vol. 142, no. 3, pp. 251-256, 1995.
- [12] A. Ahuja, S. Das and A. Pahwa "An ais-aco hybrid approach for multi-objective distribution system reconfiguration," *IEEE Transactions on Power Systems*, vol. 22, no. 3, pp. 1101-1111, 2007.
- [13] Y. Kumar, B. Das and J. Sharma, "Multiobjective, multiconstraint service restoration of electric power distribution system with priority customers," *IEEE Transactions on Power Delivery*, vol. 23, no. 1, pp. 261-270, 2008.
- [14] M. Tsai and Y. Pan, "Application of BDI-based intelligent multi-agent systems for distribution system service restoration planning," *European Transactions on Electrical Power*, vol. 21, pp. 1783-1801, 2011.
- [15] T. Nagata and H. Sasaki, "A multi-agent approach to power system restoration," *IEEE Transactions on Power Systems*, vol. 17, no 2, pp. 457-462, 2002.
- [16] X. Yinliang and L. Wenxin, "Novel multiagent based load restoration algorithm for microgrids," *IEEE Transactions on Smart Grid*, vol. 2, no. 1, pp. 152-161, 2011.
- [17] J. M. Solanki, S. Khushalani and N. Schulz, "A multi-agent solution to distribution systems restoration," *IEEE Transactions on Power Systems*, vol. 22, no. 3, pp. 1026-1034, 2007.
- [18] C.H. Lin, C.S. Chen, T.T. Ku, C.T. Tsai and C. Y. Ho, "A multiagent-based distribution automation system for service restoration of fault contingencies," *European Transactions on Electrical Power*, vol. 21, pp. 239-253, 2011.
- [19] C.P. Nguyen and A.J. Flueck, "Agent Based Restoration With Distributed Energy Storage Support in Smart Grids," *IEEE Transactions on Smart Grid*, vol. 3, no. 2, pp. 1029-1038, 2012.
- [20] H. Liu, X. Chen, K. Yu and Y. Hou, "The control and analysis of self-healing urban power grid," *IEEE Transactions on Smart Grid*, vol. 3, no. 3, pp. 1119-1129, 2012.
- [21] E. Zidan and F. El-Saadany, "A cooperative multiagent framework for self-Healing mechanisms in distribution systems," *IEEE Transactions on Smart Grid*, vol. 3, no. 3, pp. 1525-1539, 2012.
- [22] S.A. Arefifar, Y. A-R. Mohamed and T.H.M. EL-Fouly, "Comprehensive operational planning framework for self-healing control actions in smart distribution grids," *IEEE Transactions on Power Systems*, vol. 28, no. 4, pp. 4192-4200, 2013.
- [23] W. Ling and D. Liu, "A distributed fault localization, isolation and supply restoration algorithm based on local topology," *International Transactions on Electrical Energy Systems*, 2014.
- [24] M. Wooldridge, "Developing Multi-Agent Systems with JADE", John Wiley & Sons Ltd, NY, USA 2007.
- [25] A.S. Tanenbaum, "Computer Networks", Pearson Education LTD, 4th edn, 2003.
- [26] M. R. Haghifam and O. P. Malik, "Genetic algorithm-based approach for fixed and switchable capacitors placement in distribution systems with uncertainty and time varying loads," *IET Proceedings on Generation, Transmission & Distribution*, vol. 1, no. 2, pp. 244-252, 2007.
- [27] Y.Y. Hong and P.H. Chen, "Genetic-Based under frequency load shedding in a stand-alone power system considering fuzzy loads," *IEEE Transactions on Power Delivery*, vol. 27, no. 1, pp. 87-95, 2012.
- [28] B. Wang, Y. Li and J. Watada, "Supply reliability and generation cost analysis due to load forecast

- uncertainty in unit commitment problems,” *IEEE Transactions on Power Systems*, vol.28, no.3, 2014.
- [29] Z. Liu, F. Wen and G. Ledwich “Optimal siting and sizing of distributed generators in distribution systems considering uncertainties,” *IEEE Transactions on Power Delivery*, vol. 26, no. 4, pp. 2541-2551, 2011.
- [30] A. Bracale, G. Carpinelli, D. Proto, A. Russo and P. Varilone, “New approaches for very short-term steady-state analysis of an electrical distribution system with wind farms,” *Energies*, vol. 3, no. 4, pp. 650-670, 2010.
- [31] A. Bracale, P. Caramia, G. Carpinelli, A.R.D. Fazio and P. Varilone, “A bayesian-based approach for a short-term steady-state forecast of a smart grid,” *IEEE Transaction on Smart Grid*, vol.4, no. 4, pp. 1760-1771, 2013.
- [32] M.N. Kabir, Y. Mishra, G. Ledwich, Z.Y. Dong and K.P. Wong, “Coordinated control of grid connected photovoltaic reactive power and battery energy storage systems to improve the voltage profile of a residential distribution feeder,” *IEEE Transactions on Industrial Informatics*, vol.10, no.2, 2014.
- [33] M. Ma, M. Friedman and A. Kandel, “A new fuzzy arithmetic,” *Fuzzy Sets and Systems*, vol. 108, pp. 83-90, 1999.
- [34] G. Bortolan and R. Degani, “A Review of Some Methods for Ranking Fuzzy Subsets,” *Fuzzy Sets and Systems*, vol. 15, pp. 1-19, 1985.
- [35] S. Abbasbandy and T. Hajjari “A new approach for ranking of trapezoidal fuzzy numbers,” *Computers and Mathematics with Applications*, vol. 57, pp. 413-419, 2009.
- [36] L. A. Wolsey, “*Integer Programming*”, John Wiley & Sons Ltd , NY, USA, 1998.
- [37] D. Das, “Reconfiguration of distribution system using fuzzy multi-objective approach,” *Electrical Power and Energy Systems*, vol. 28, pp. 331-338, 2006.
- [38] M. M. Hamada, M.A.A. Wahab and N.G.A. Hemdan, “Simple and efficient method for steady-state voltage stability assessment of radial distribution systems,” *Electric Power Systems Research*, vol. 80, pp. 152-160, 2010.