



Intelligent Power Control of Zero Energy Building-Integrated of Fuel Cell and Plug-in Electric Vehicle in Smart Distribution Systems

Mohammad Iman Ghiasi¹, Masoud Aliakbar Golkar², Amin Hajizadeh³

¹Department of Power Electrical Engineering, Science and Research branch, Islamic Azad University, Tehran, Iran, m.ghiasi@srbiau.ac.ir

²Department of Electrical and Computer Engineering, K.N.Toosi University of Technology, Tehran, Iran, golkar@kntu.ac.ir

³Department of Electrical Engineering, University of Shahrood, Shahrood, Iran, aminhajizadeh@shahroodut.ac.ir,

Abstract

The renewable energy sources and plug-in electric vehicles (PEVs) are becoming very popular because of the combination of high fuel costs and concerns about emission issues. This paper presents modelling and control of a Building Integrated Fuel Cell and Plug-in Electric Vehicles (BIFC-PEV) in smart distribution systems. In BIFC-PEV system, conventional building elements could be replaced by special fuel cell and PEV for delivering power to the house. The interest in battery electric vehicles (BEVs) and plug-in electric vehicles (PEVs) has increased due to their impact on redistribution of the pollution from tail pipe to smog stuck, low-cost charging, and reduced petroleum usages. First, the overall configuration of the BIFC-PEV including dynamic models of fuel cell, battery and its power electronic interfacing are briefly described. Then, to distribute the power between power sources, the fuzzy power controller has been developed to stabilize the DC-link power. Simulation results are illustrated to demonstrate the effectiveness and capability of proposed control strategy during different operating conditions in utility grid.

Keywords: BIFC-PEV, Power Control, Renewable Energy, Fuel Cell, Energy Storage.

© 2015IAUCTB-IJSEE Science. All rights reserved

1. Introduction

With the developing of the intelligent technologies, it is safe to say that smart building is becoming more attractive as well as more viable in the building industry. Generally speaking, smart buildings are expected to address both intelligence and sustainability issues by utilizing computer and intelligent technologies to achieve the optimal combinations of overall comfort and energy consumption, as well as using renewable energy to reduce the impact on natural environment. Building-Integrated Fuel cell and Plug-in Electric Vehicle (BIFC-PEV) is the important form using renewable energy in future city. In BIFC-PEV system, conventional building elements could be replaced by special fuel cell and PEV for delivering power to the house. The interest in battery electric vehicles (BEVs) and plug-in electric vehicles (PEVs) has increased due to their impact on redistribution of the pollution from tail pipe to

smog stuck, low-cost charging, and reduced petroleum usages. Compared with traditional hybrid electric vehicles (HEVs), BEVs/PEVs have an enlarged battery pack and an intelligent converter. Using a plug, BEVs/PHEVs can charge the battery using electricity from an electric power grid, also referred to as “grid-to-vehicle” (G2V) operation, or discharge it to an electric power grid during the parking hours, also referred to as “vehicle-to-grid” (V2G) operation [1].

Many researchers have investigated the various potential benefits and implementation issues of V2G concept. The fundamentals of using BEVs/PHEVs for load levelling, regulation, reserve, and other purposes have been presented in [2], [3]. The potential impacts of BEVs/PHEVs on electricity demand, supply, generation, infrastructure, prices, and associated emission levels in 2020 and 2030 in 13 regions specified by

the North American Electric Reliability Corporation (NERC) has been analyzed in [4]. The impacts of BEVs/PHEVs on electric power network components have been considered in [5]. The optimal V2G aggregator for frequency regulation by applying the dynamic programming algorithm to compute the optimal charging control for each vehicle has been presented in [6]. In [7-8] also discussed power system frequency control by using V2G system. The case studies of plug-in hybrid electric vehicles if used by regulating power providers in Sweden and Germany are performed in [9].

The aggregated BEV-based battery storage for the use in long-term dynamic power system simulation when integrating V2G in the western Danish power system are modeled in [10]. According to presented research studies, it is evident that the integration of renewable energy sources with plug-in electric vehicle for supplying power to building is an important problem which should be considered carefully. Hence, in this paper an intelligent power control for building integrated fuel cell and plug-in electric vehicle is proposed. In order to build the BIFC-PEV in Simulink environment, mathematical models of fuel cell,

battery, power electronic converters are implemented. Furthermore, control strategy for managing power between smart building, fuel cell power source and PEV is developed. Finally, simulation analyses for different case studies are presented.

1. Proposed System Framework Description

As the Fig. 1 shows, the overall system is composed of the utility power grid, the building system, the renewable energy resource and the PEV system. In this paper, the renewable energy resource includes fuel cell which is green energy with zero CO₂ emission. The PEV system could be considered as a new form of distributed storage. It is combined with the distributed renewable energy resource and the controllable load (the smart building) to form BIFC-PEV system. The dynamic models for each power sources, energy storage and power electronic converters are given in [11-13].

To measure the controllability of the EM mode of test system from each of the four inputs: δ_1 , δ_2 , m_1 , m_2 , the SVD is estimated in [12] so that The EM mode is more controllable with m_1 , m_2 than with either δ_1 , δ_2 .

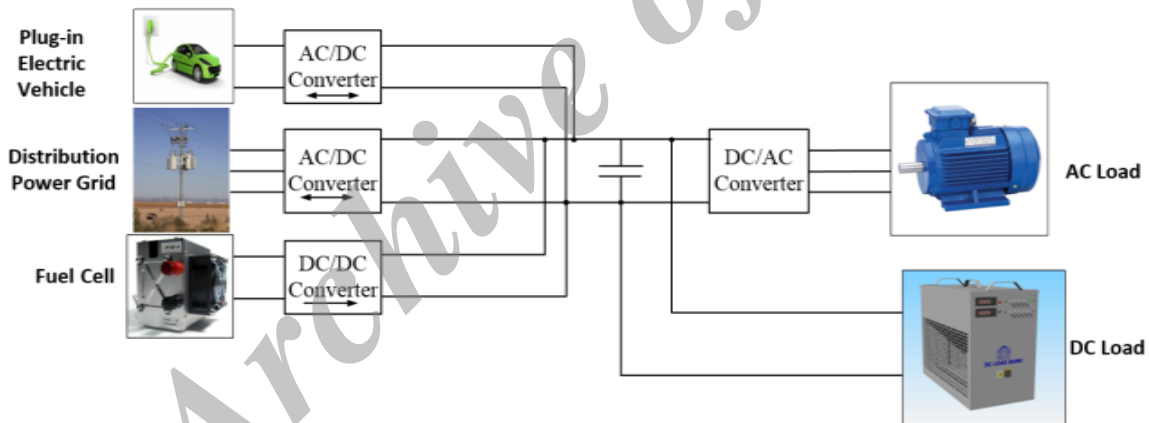

Fig. 1. Proposed controller structure

2. Power Flow Control

Power flow control from fuel cell and PEV to smart building and to/from grid is required to maintain power balance at all times while satisfying the active and reactive power demanded by the home electrical load. Equation (1) gives power balance expressions that should be satisfied both at the DC-link and at the PCC at all times. The rate and magnitude of fuel cell power P_{FC} and rate, sign and magnitude of PEV power P_{PEV} depend on the magnitude and how fast the load changes.

According to the control strategy proposed in this paper, P_{Home} and Q_{Home} are made equal to P_{ref} and Q_{ref} so that the hybrid System (HS) output follows the home load demand under normal

loading conditions and P_{Grid} and Q_{Grid} are zero. If the home load demand exceeds the hybrid power system capacity, the rest of the power is supplied

$$\begin{aligned} P_{HS} &= P_{FC} + P_{PEV} \\ P_{Home} &= P_{HS} + P_{Grid} \\ Q_{Home} &= Q_{HS} + Q_{Grid} \end{aligned} \quad (1)$$

from the grid. Fig. 2 shows the overall structure of the control strategy.

The control strategy also keeps the DC-link/battery voltage within a band around the nominal DC-link voltage to keep the inverter in synchronism with the grid. The following

differential equation for DC link power balance is given:

$$C_{dc}V_{dc} \frac{dv_{dc}}{dt} = P_{PEV} + P_{FC} - P_{home} \quad (2)$$

According to the Eq. (31), in order to regulate the DC-link voltage it is necessary to keep the power balance in DC-link. In this equation, the change in home power is considered as disturbance during the load power variations. Moreover, to meet the power balance in DC-link it is important to consider the physical limitations of fuel cell power. In addition, the amount of power that should be absorbed by battery energy storage to balance the power in DC-link is very important and it depends on the DC-link energy. The DC-link energy measurement is carried out by means of the following calculation:

$$E_{dc}(k) = \left(\frac{1}{2}\right)C_{dc}V_{dc}^2(k) \quad (3)$$

In this paper, a power flow control structure has been developed for hybrid sources. It is based on Fuzzy Logic Control (FLC) strategy that determines the PEV power according to the following inputs:

$$e(k) = E_{dc-ref}(k) - E_{dc}(k) \quad (4)$$

$$\Delta e(k) = e(k) - e(k-1)$$

Edc-ref is the reference dc link energy which is calculated by reference dc link voltage.

Hence, it is essential to design robust and stable control strategy to guarantee the stability of the dc link of hybrid system. For this purpose, a fuzzy control strategy is developed [22].

3. Intelligent Control of DC-Link Power

In order to achieve a stabilized control, the control system structure is analyzed. Hence, in this paper, a hybrid fuzzy/ state feedback control structure has been developed [10].

The block diagram of the hybrid fuzzy/ PI controller is shown in Fig.6. In this structure, the fuzzy controller sets output voltage of DC-link on operating point. Then, fuzzy controller adjusts the firing angle of AC-DC converter during operating point variations that might be occurred when load current changes. In fact, the role of PEV is shown well to operate as Demand Side Management (DSM) operator. The PEV could deliver the power to building when the house electrical load is much bigger than the fuel cell power. Furthermore, PEV's battery could be charged during light electrical load.

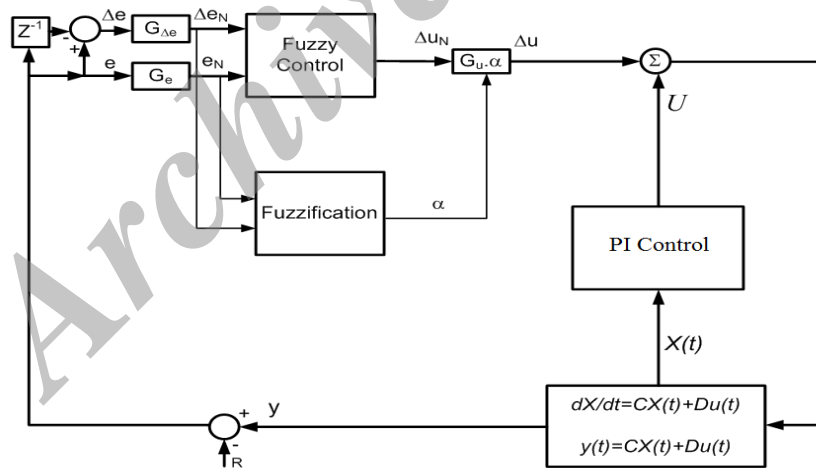

Fig. 2. block diagram of the hybrid fuzzy/ state feedback controller

By using the scaling factors (SFs) G_e , $G_{\Delta e}$, the quantities e and Δe are converted to normalized e_N and Δe_N . These normalized quantities e_N and Δe_N are crisp in nature and therefore need to be first converted to their corresponding fuzzy variables. After fuzzification, the fuzzified inputs are given to the fuzzy inference mechanism which, depending on the given fuzzy rule base, gives the normalized incremental change in control output (Δu_N). The output Δu_N is converted into actual

incremental change in control output (Δu) by using the scaling factor G_u . For the implementation the fuzzy inference engine, the “min” operator for connecting multiple antecedents in a rule, the “min” implication operator, and the “max” aggregation operator have been used [10].

Actually, the output Δu_N from the inference mechanism is fuzzy in nature, hence, to determine the crisp output, the defuzzification stage is applied. The centroid defuzzification scheme has been used

here for obtaining the output Δu . Finally, the actual value of the controller output (u) is computed by:

$$u(k) = u(k-1) + \Delta u(k) \tag{5}$$

The relationships between the SFs and the input and output variables of the self-tuning FLC are as follow:

$$\begin{aligned} e_N &= G_e \cdot e \\ \Delta e_N &= G_{\Delta e} \cdot \Delta e \\ \Delta u &= (\alpha \cdot G_u) \cdot \Delta u_N \end{aligned} \tag{6}$$

In this scheme, the FLC is tuned on-line (while the controller is in operation) by dynamically adjusting its output scale factor by a gain updating factor (α). The value of α is determined from a rule base defined on e and Δe and derived from the knowledge of control engineering. Generally, selection of suitable values for G_e , $G_{\Delta e}$ and G_u are made based on the knowledge about the process to be controlled and sometimes through trial and error to achieve the best possible control performance. This is so because, unlike conventional non-fuzzy controllers, there is no well-defined method for selecting appropriate values of SFs for FLC.

Each fuzzy control rule in the controller rule base is of the form:

A) Rule: If e is E and Δe is ΔE , then Δu is ΔU

Where E , ΔE and ΔU are the fuzzy sets corresponding to error, change in error and the incremental change in the control output, respectively. In this work, for both the inputs (e and Δe) and the output (Δu), seven fuzzy subsets have been used. These are: PB (positive big), PM (positive medium), PS (positive small), ZE (zero), NS (negative small), NM (negative medium) and NB (negative big).

For each of these fuzzy sets, triangular membership function (MF) has been used [22]. From this figure it is observed that the triangles are symmetric with equal base having 50% overlap with neighboring MFs.

As each of the two inputs has seven fuzzy sets, there are altogether 49 control rules in the FLC. The rule base for computing the output Δu is shown in Table 1 which is a widely used rule base designed with a two dimensional phase plane. The control rules in Table 2 are built based on the characteristics of the step response.

Moreover, the gain updating factor (α) is calculated using fuzzy rules of the form:

B) Rule: If e is E and Δe is ΔE then α is α .

From Fig. 9 it is observed that the value of α is computed from the normalized values of e and Δe

by a fuzzy rule base. The membership functions used for e and Δe are exactly same as those used in FLC. Moreover, the same fuzzy operators also been used in this case. The membership functions for the factor α are defined in the domain $[0,1]$.

As each of the two inputs (e and Δe) to the fuzzy rule base (corresponding to α) has seven fuzzy variables, the rule base has 49 rules for computing the value of α . Table 2 shows the rule base for computing α . This rule base has been designed to improve the control performance under large disturbances such as three-phase short circuit on the transmission lines, a sudden loss of generating unit or a large loss of load, etc. For example, immediately after a large disturbance, e may be small but Δe will be sufficiently large (they will be of same sign) and, for this case, α is supposed to be large to increase the gain.

Therefore, under these circumstances, the appropriate rules are “IF e is PS and Δe is PM THEN α is B” or “IF e is NS and Δe is NM THEN α is B”. On the other hand, for steady state conditions (i.e., $e \approx 0$ and $\Delta e \approx 0$), controller gain should be very small (e.g., IF e is ZE and Δe is ZE THEN α is ZE) to avoid chattering problem around the set point. Further justification for using the rule base in Table 2 can be found in [10].

The control signal is fed to the PWM generator. The PWM generator based upon the control signal adjusts the pulses of the switch of the boost converter.

Table.1.
Rule base for computing the output Δu

| $\Delta e/e$ | NB | NM | NS | ZE | PS | PM | PB |
|--------------|----|----|----|----|----|----|----|
| NB | NB | NB | NB | NM | NS | NS | ZE |
| NM | NB | NM | NM | NM | NS | ZE | PS |
| NS | NB | NM | NS | NS | ZE | PS | PM |
| ZE | NB | NM | NS | ZE | PS | PM | PB |
| PS | NM | NS | ZE | PS | PS | PM | PB |
| PM | NS | ZE | PS | PM | PM | PM | PB |
| PB | ZE | PS | PS | PM | PB | PB | PB |

Table.2.
Rule base for computing the output α

| $\Delta e/e$ | NB | NM | NS | ZE | PS | PM | PB |
|--------------|----|----|----|----|----|----|----|
| NB | VB | VB | B | SB | S | S | ZE |
| NM | VB | VB | B | B | MB | S | VS |
| NS | VB | VB | B | VB | VS | S | VS |
| ZE | S | SB | MB | ZE | MB | SB | S |
| S | VS | S | VS | VB | B | MB | VB |
| PM | VS | S | MB | B | B | VB | VB |
| PB | ZE | S | SB | B | VB | VB | VB |

4. Simulation Results

In order to verify the mathematical model of fuel cell, converter and controller the whole system has been simulated in MATLAB software environment. It is supposed that fuel cell is supplied 5KW of active power. Moreover, it is assumed that the output voltage of DC-DC converter should be regulated at 100V under different load current conditions. For analyzing fuel cell power generation system with designed control strategy, three cases for simulation conducted that described as continue. According to the presented results, it is achieved that the proposed control strategy is very suitable for fuel cell power generation system. In fact, by this control strategy the output voltage of fuel cell is regulated under different loading conditions and existing disturbances which may occur in fuel cell stack. Moreover, this control strategy is proper for BIFC-PEV during requested power from load. For this purpose, a simulation of results based on the requested load power (Fig.3) is performed. In Fig. 4 variations of fuel cell current and voltage are illustrated.

In Fig. 5 voltage and current variations for PEV's battery are shown. In this case, it is supposed the PEV has been connected to building and could absorb and deliver power from building. As illustrated, battery energy storage could deliver

and absorb some power during different loading conditions. In this condition, regulated voltage of DC-DC converter is presented in Fig. 6. In order to present that fuel cell and PEV supply the load power, in Fig.8 the output power of fuel cell and battery and load active power are illustrated. As shown, PEV could deliver and absorb the power to keep the power balance in building. Moreover, the battery's state of charge (SOC) is presented in Fig.8.

5. Conclusion

In this paper intelligent control of a Building Integrated fuel cell and Plug-in Electric Vehicles (BIFC-PEV) in smart distribution systems is investigated. The overall configuration of the BIFC-PEV including dynamic models of fuel cell, battery and its power electronic interfacing are briefly described. Then controllers design methodologies for power electronic converters in order to manage the power flow from BIFC-PEV to the utility grid during normal operation is introduced. Moreover, to distribute the power between power sources, the fuzzy power controller has been developed to stabilize the DC-link power. Simulation results are illustrated to demonstrate the effectiveness and capability of proposed control strategy during different operating conditions in utility grid.

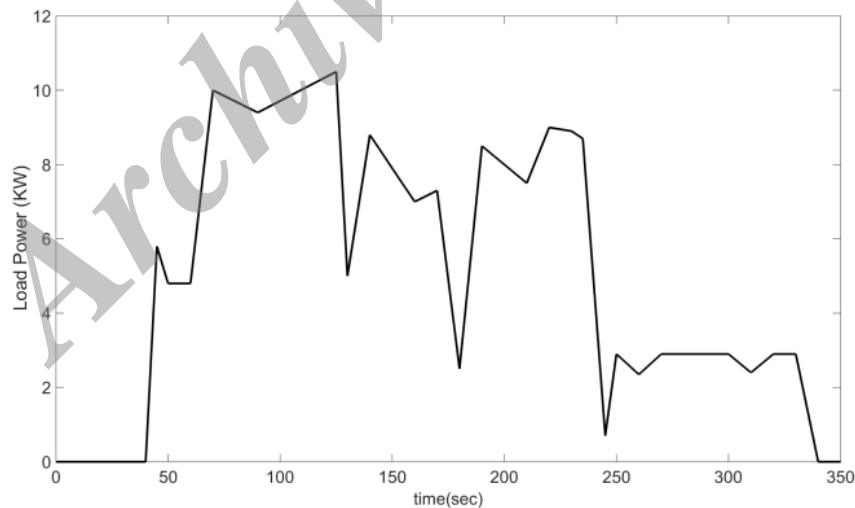

Fig. 3. Load active power

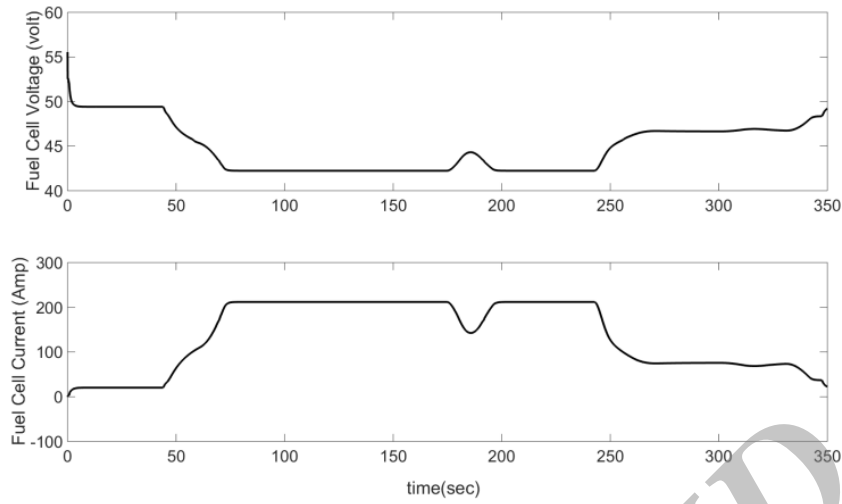

Fig. 4. Variations of fuel cell current and voltage in fuel cell electric ship

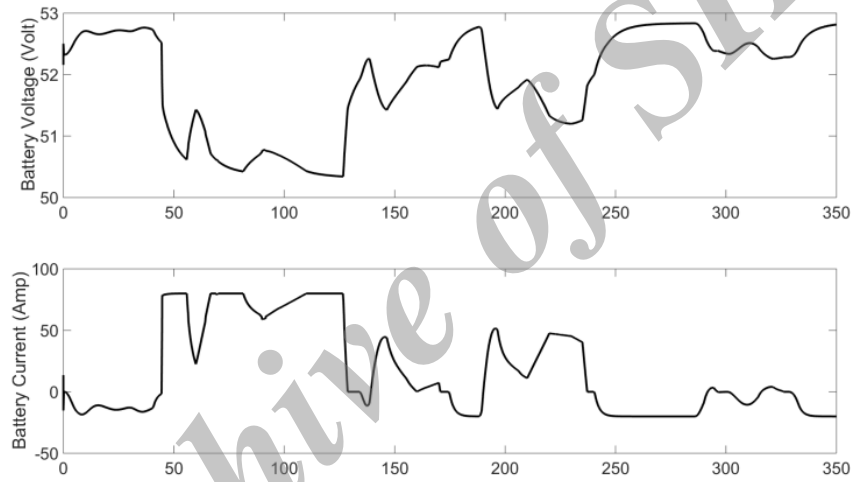

Fig. 5. Variations of battery current and voltage of PEV

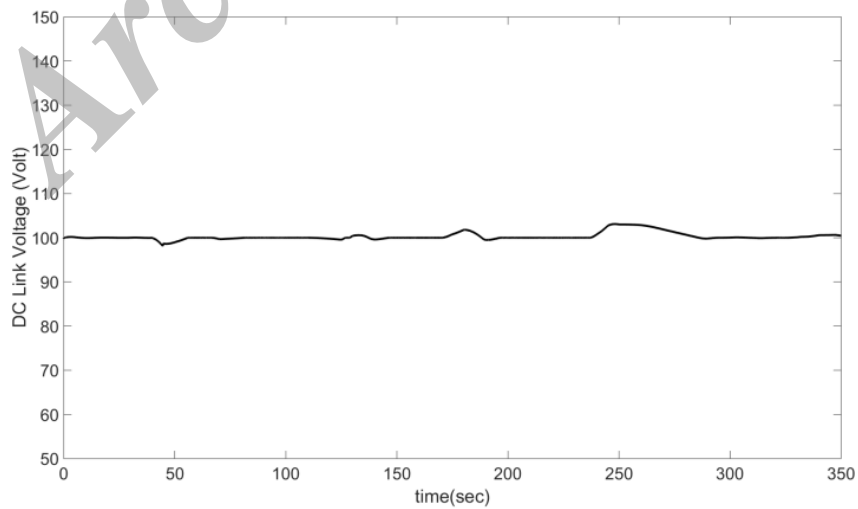

Fig. 6. Output voltage of DC-DC converter in BIFC-PEV

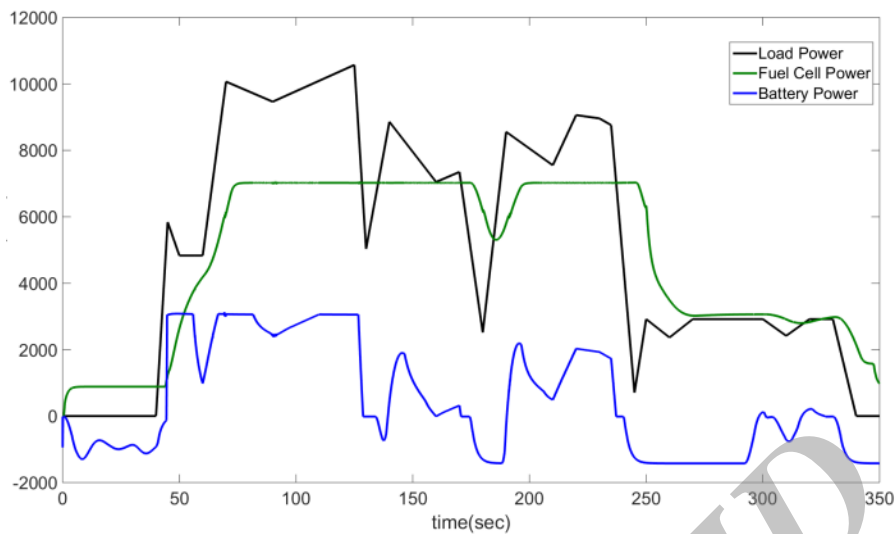

Fig. 7. Output power for fuel cell, battery and load

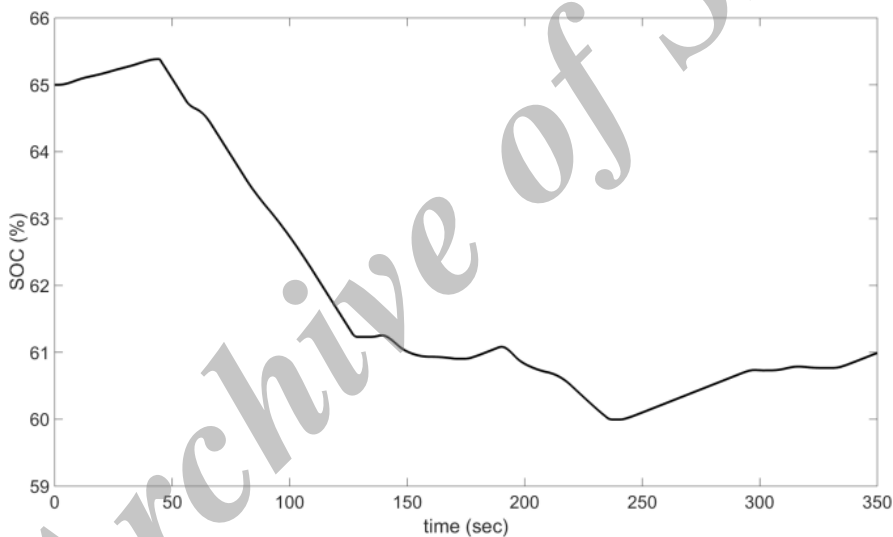

Fig. 8. Battery's state of charge (SOC)

References

- [1] H. Hens and A. Janssens, Building, living and energy in Energy Today and Tomorrow. Leuven: ACCO, , pp. 133-151,2006.
- [2] G.R.K.D.Satya Prasad, K. Vijaya Kumar Reddy, Ch. Saibabu "Integration Of Renewable Energy Sources In Zero Energy Buildings With Economical And Environmental Aspects By Using Homer", International Journal Of Advanced Engineering Sciences And Technologies, Vol No. 9, Issue No. 2, 212 – 217,2012.
- [3] H. Turker , S. Bacha , D. Chatroux and A. Hably "Modeling of system components for vehicle-to-grid (V2G) and vehicle-to-home (V2H) applications with plug-in hybrid electric vehicles (PHEVs)", Proc. IEEE PES Innovative Smart Grid Technol, 2012
- [4] J. F. Martins, V. Fernão Pires, Luis Gomes, O. Páscoa Dias, "Plug-in electric vehicles integration with renewable energy building facility – building/vehicle interface", IEEE POWERENG ,2009.
- [5] Bedir, B. Ozpineci, J. E. Christian, "The Impact of Plug-in Hybrid Electric Vehicle Interaction with Energy Storage and Solar Panels on the Grid for a Zero Energy House", Transmission and Distribution Conference and Exposition, 2010.
- [6] Zhu Wang, Lingfeng Wang, Anastasios I. Dounis, and Rui Yang, "Integration of Plug-in Hybrid Electric Vehicles into Building Energy Management System", Power and Energy Society General Meeting, 2011 .
- [7] A.J. Marszal, P. Heiselberg, J.S. Bourrelle, E. Musall, K. Voss, I. Sartori , A. Napolitano, "Zero Energy Building – A review of definitions and calculation methodologies", Journal of Energy and Buildings, Vol.43, 971-979, 2011.
- [8] R. Baetens, R. De Coninck, J. Van Roy, B. Verbruggen, J. Driesen, L. Helsen, D. Saelens, "Assessing electrical bottlenecks at feeder level for residential net zero-energy buildings by integrated system simulation", Journal of Applied Energy, Vol.96, 74-83, 2012.
- [9] Pang, P.Dutta, M. Kezunovic, "BEVs/PHEVs as Dispersed Energy Storage for V2B Uses in the Smart Grid", IEEE TRANSACTIONS ON SMART GRID, VOL. 3, NO. 1, MARCH 2012.

- [10] Zhu Wang, Lingfeng Wang, Anastasios Dounis, Rui Yang, "Integration of plug-in hybrid electric vehicles into energy and comfort management for smart building", *Journal of Energy and Buildings*, Vol.47, 260-266, 2012.
- [11] Hajizadeh, M.A. Golkar. "Control of hybrid fuel cell/battery distributed power generation system with voltage sag ride-through capability", 2nd International Conference of Power and Energy Conference, 2008.
- [12] Padulles, J., G. Ault and J. McDonald, "An integrated SOFC plant dynamic model for power systems simulation", *Journal of power sources*, 86(1): 495-500,2014.
- [13] T.C. Chen., *Linear system theory and design*: Oxford University Press, Inc,2014
- [14] R.K.Mudi,N.R. Pal,. A robust self-tuning scheme for PI- and PD-type fuzzy controllers, *IEEE Transactions on Fuzzy Systems*, 7(1): 2-16, 1999.
- [15] Golden, C., 2009. *National Renewable Energy Laboratory*. Richland, WA: Pacific Northwest National Laboratory,2009.

Archive of SID