

Original Research

Designing and Manufacturing of the Mechanical Displacement Helper System

Sajjad Pashaie^{1*}, Fatemeh Abdavi², Shirin Yazdani³

1-2. Department of Sport Management, Faculty of Physical Education & Sport Sciences, University of Tabriz, Tabriz, IRAN

3. Department of Motor Behavior, Faculty of Physical Education & Sport Sciences, University of Tabriz, Tabriz, IRAN

ABSTRACT

Mechanisms of assistive mechanical- movement and therapeutic devices are derived from treadmill, walker and manual sliding and sliding movements, where a person is placed on a skeleton of a cubic-shaped rod and rotates the front wheels by 180 degrees by moving and sliding one of the handles and by moving the second batch, the remaining 180 degrees of forward rotation is made and the device moves in successive motion. The technical background of the invention is in the field of rehabilitation engineering or assistive devices for people with movement disorders and disabilities. The wheels are elastic, and the electronic eye in front of the walker collides with the brakes. The lower part is mounted independently of the treadmill for each leg, with the simultaneous application of different loading mechanisms for the lower limbs, which allows the person to move through the rear wheels and move the machine forward. In addition to ease of movement for the person with a variety of disabilities and lower extremity abnormalities, this device does not apply pressure to the injured foot or both legs.

Keywords: Anomalies, Helper, Disabled.

Introduction

Today, quality of life is one of the main indicators of society, which includes the most important factors that determine living conditions in society and personal well-being [1]. Walking as an important task in everyday life is a dynamic, complex and rhythmic task [2]. To control stature and maintain rhythm and stability in walking, a complex control system is needed that can adapt to internal and external changes. This control system is dependent on the coordination of sensory systems that are able to recognize the position and movement of the body and the visual environment, and the operating organs that produce transient and kinetic responses [3- 4].

By getting old, the risk of falling is also increased [5]. The risk of falls is much more common in old age. Approximately 30% of people over the age of 65 experience a fall during the year [6]. The aging process brings about physiological changes in various sensory systems as well as the movement system [3], resulting in changes in gait pattern such as reduced gait speed, shorter step length, increased dual support duration, reduction of the stepping rate, increasing momentum fluctuations, and greater variability of spatial-temporal parameters are created [7-8].

The World Health Organization (WHO) has defined disability as a disruption to the relationship between itself and the environment. In other words, disability is a set of physical, mental, social or a combination of factors that somehow negatively impact one's personal life and preclude the continuation of his or her independent life naturally [9].

The natural movements of the lower limbs that are affected by injury, old age, disability, or illness can be partially offset by assistive devices [10]. Widespread utility in sporting endeavors and more recently have been applied by consumers and researchers [11]. Creativity or creativeness is one of the most important abilities of human beings and the most fundamental factor in creating value that plays a vital role in all aspects of his life.

Today, with the rise of technology, we are witnessing new advances in the world of motor assisted vehicles. In ancient times, the cane looked like protective clothing and was considered a reasonable cover. Nowadays this cane application is almost obsolete and just like a walker or a wheelchair, it is considered to be an auxiliary motor vehicle that is often used to help maintain balance in the injured person. People with pain and weakness in one or both legs took the cane and walker as a motor aid and tried to maintain balance while walking. In such cases an ordinary cane was sufficient and would greatly help the user. The use of the cane put a lot of pressure on the injured limb and was frustrating (such as those with knee pain, arthritis, or pelvic pain). People who have fractures in the lower extremities or for the same reason have been operated on the lower extremities use a walker, elbow cane, or armpit. However, using traditional methods of motor aids not only does not help the injured person but also causes other problems and pain (wrist or elbow pain, Figure 1)

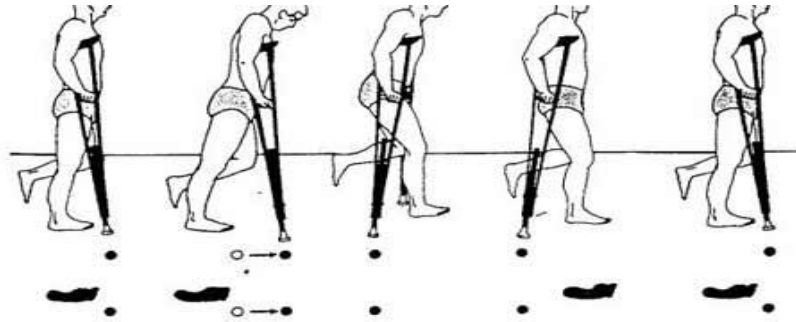

Figure 1. Improper use and excessive pressure on the limbs

Among the simpler walking aids available in the market (walker, cane), the user can begin walking with a walker or cane. However, the elderly, the disabled or newly injured people need surgery to get good help in walking. A mechanical displacement assistive device is an auxiliary device used to maintain balance in people with disabilities, weakness or movement disabilities.

Technical Field of Invention

The technical field of the invention is in the field of rehabilitation engineering or assistive devices for people with movement disorders and disabilities and the basis of its design is to help a variety of groups of disabled patients, including the elderly, neuromuscular patients, stroke and the like, as well as patients with knee pain and severe instability in the knees and thighs, who cannot walk easily and with less pressure on the hands and feet and maintain proper balance with the help of existing walkers in the market.

Material and Methods

Mechanical and electronic parts were used to make this device;

A) Mechanical Part:

In this section, VariCAD software was used to design mechanical components. Figure 2 shows the main components of the mechanical part of the software output.

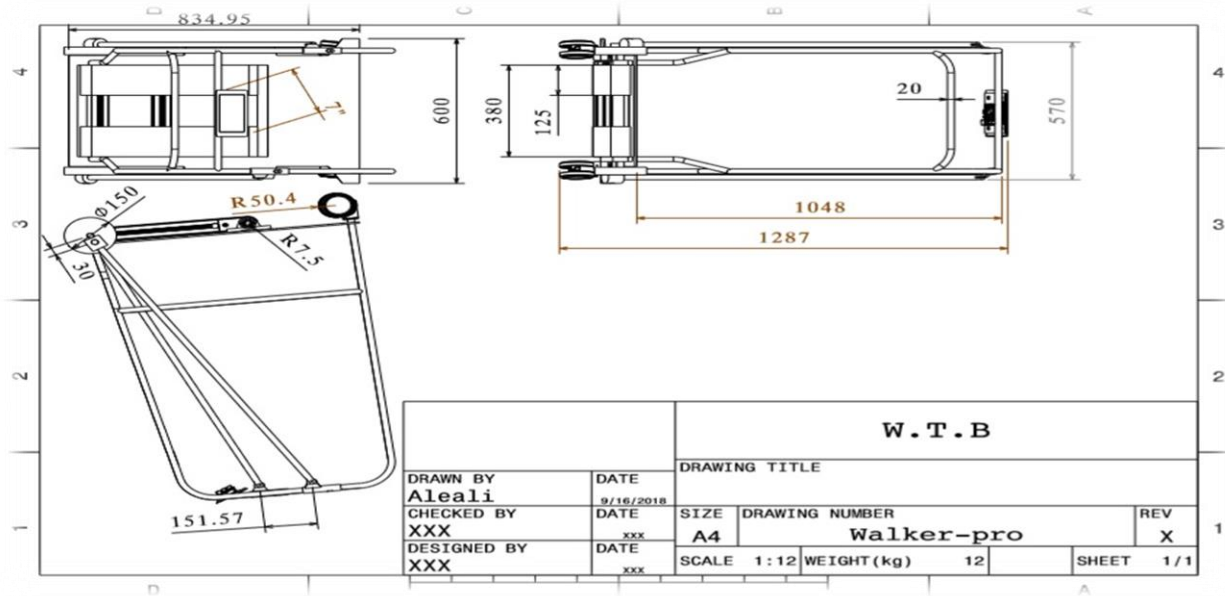

Figure 2: The main components of the mechanical part

Moving Knob:

Linear motion is caused by the back and forth movement of the hands by the arm to the wheels and it moves the injured person forward.



Figure 3: Moving knob

Machine Wheels

A view of the rear wheels moves on the treadmill by walking (Figure 4). But by linear and sliding movement of one of the handles, the front wheels spin about 180 degrees and by moving the second batch, it performs the remaining 180 degrees forward and moves the device in a continuous motion and the electronic eye in front of the walker collides with the brakes (Fig. 5, 3).

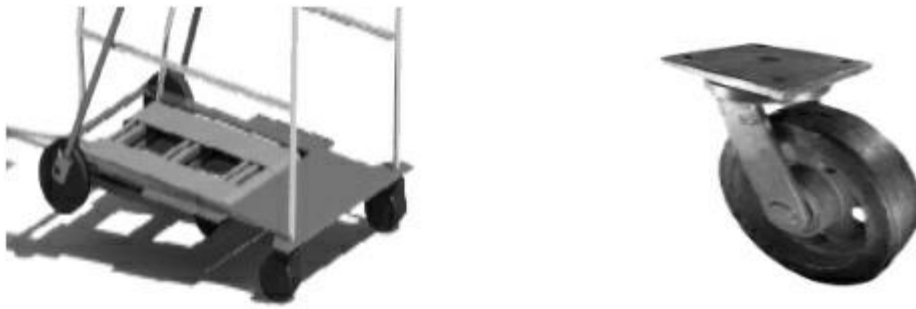

Figure 4: Rear wheels of the machine

A view of the rear wheels moves on the treadmill by walking (Figure 4). But by linear and sliding movement of one of the handles, the front wheels spin about 180 degrees and by moving the second batch, it performs the remaining 180 degrees forward and moves the device in a continuous motion and the electronic eye in front of the walker collides with the brakes (Fig. 5, 3).

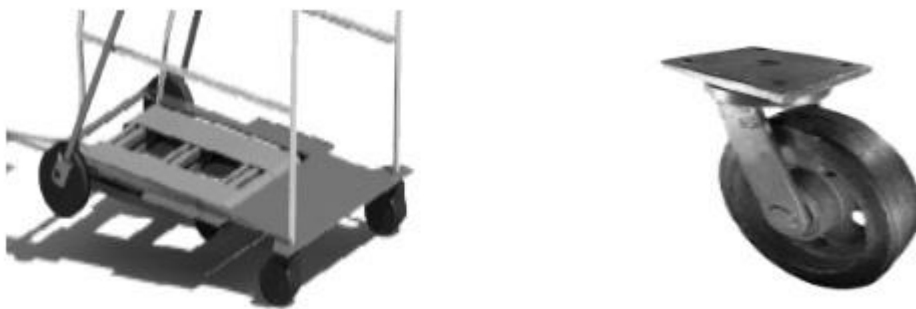

Figure 4: Rear wheels of the machine

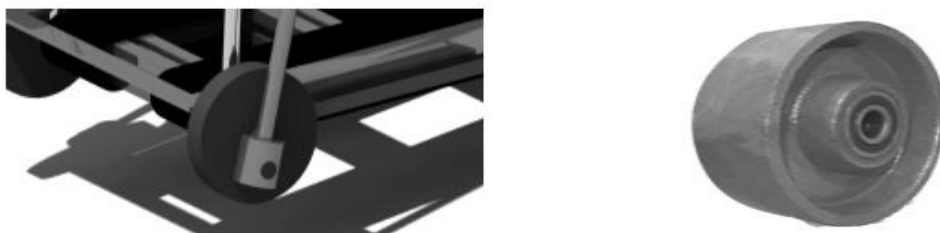

Figure 5: Front wheels of the machine

Device Treadmill

Treadmill straps or machine straps are one of the main parts of the present device that with the power of the legs, the device rotates and starts working. Machine strap resistance is important because it is directly in relation with the foot of the walker and is in constant rotation and friction. Machine strap in its lower surface with fixed device surface (body), uses device rollers at the top and bottom and also direct pressure from the user in the upper surface. When the person starts walking on the machine, the machine straps are repeatedly pressed and

struck with each step. Therefore, the resistance of straps against abrasion and traction is one of the most important points in choosing the strap of the present device (figure 6).

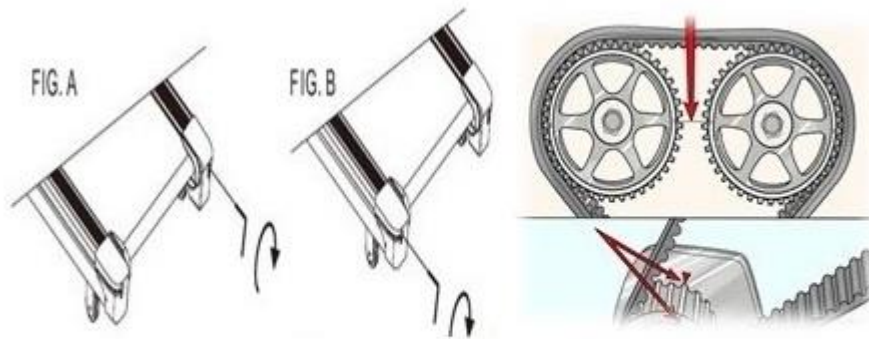

Figure 6: Device treadmill

One of the benefits of this mechanism is that the treadmills are separate to apply different working pressure loads for each leg, which causes the actual movement of the healthy foot against the injured foot. It means there are two foot-steps for legs that have predetermined resistance levels that apply differently for both feet. So, the user can move the device by walking on it.

B) Electronic Part:

In this section, Proteus software was used to design electronic components. This part of the device is used to display the steps taken, to test and measure blood pressure and heart rate, GPS and calories (Figure 7).

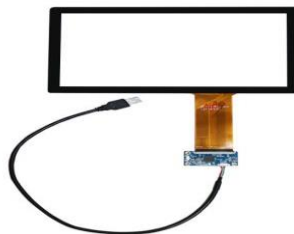

Figure 7: Device panel

Components of Inventive Elements in the Electronic Sector:

1. **Heart rate sensor:** The heart rate sensor measures your heart rate in beats per minute using an optical LED light source and an LED light sensor.
2. **Using piezoelectric sensor:** Piezoelectricity is the charge created across certain materials when a mechanical stress is applied. Piezoelectric pressure sensors exploit this effect by measuring the voltage across a piezoelectric element generated by the applied pressure. They are very robust and are used in a wide range of industrial applications.
3. **Wi-Fi module:** WiFi Module is a self-contained SOC with integrated TCP/IP protocol stack that can give any microcontroller access to your WiFi network. The ESP8266 is capable of either hosting an application or offloading all Wi-Fi networking functions from another application processor.

4. **Arduino boards:** Arduino is an open-source electronics platform based on easy-to-use hardware and software. Arduino boards are able to read inputs - light on a sensor, a finger on a button, or a Twitter message - and turn it into an output - activating a motor, turning on an LED, publishing something online.
5. **Monitor:** A monitor is an electronic visual computer display that includes a screen, circuitry and the case in which that circuitry is enclosed.
6. **Battery:** A battery is a device consisting of one or more electrochemical cells with external connections for powering mechanical displacement helper system.
7. **MPC6001 IC :** The MP6001 is a monolithic Fly back/Forward DC-DC converter which includes a 150V power switch and is capable of delivering up to 15W output power. It can also be used for boost and SEPIC applications. The MP6001 uses the fixed-frequency peak current mode primary controller architecture.
8. **SENSE electronic board:** Using two clamp-on sensors and a 240V breaker, the Sense monitor samples current and voltage one million times per second to determine where your energy is going.

Findings

Claim 1: Because the machine can withstand up to 120 kg force, the use of mounts (Fig. 8 No. 1, 6) and screws M10 for each wheel, are 4 (Fig. 8 No. 7, 13).

Claim 2: According to claim 1, the wheels have a metal and screw connection which are suitable for holding the wheel and allow them to rotate (Fig. 8, No. 6, 7, and 13).

Claim 3: According to claim 1, solid wheels were used due to the front wheels not being flat tyred (Fig. 8 No. 7).

Claim 4: According to claim 1, the rear wheels are a tire-bearing rubber thigh wheels and were used to withstand high volume and weight (Fig. 8 No. 13).

Claim 5: According to claim 2, since the wheels are highly efficient at smooth and uneven surfaces and because the wheels are adapted to a depth of 15 centimeters or holes, the wheels are 30 cm in diameter (Figure 8, Nos. 7, 13).

Claim 6: The wheels are claimed to be elastic and impactable and the electronic eye in Figure 8 number (5) in front of the walker brakes while facing obstacles (Figure 8 No. 7).

Claim 7: It is claimed that the sliding handle (Fig. 8 No. 3, 4) performs a 20cm forward-backward movement, and the front wheels rotate by 180 degrees (Fig. 8 No. 7).

Claim 8: According to claim 7, the way the arms are attached to the wheels is off-center, which causes them to move (Fig. 8, Nos. 3, 4, 7).

Claim 9: The use of a metal shank (Fig. 8 No. 14) was used to lay the person's foot on it.

Claim 10: It is claimed that a treadmill belt or treadmill strap rotates, as one steps on it (Figure 8, No. 14).

Claim 11: According to claim 8, number 10, for the left and right legs, the speed and rhythm of the main movement of the shift is adjusted non-automatically and by the individual stepping (Figure 8, Nos. 8, 9).

Claim 12: According to claim of figure 8, numbers 10 and 11, the treadmill bar is adjusted for the left and right legs for simultaneous different workloads (Figure 8 No. 8).

Claim 13: Using the display panel on the device is to display the taken steps, test and measure of blood pressure and heart rate, GPS, and calories (Figure 8 No. 5).

Claim 14: Treadmill straps at their lower surface Fig. 8 (10, 11, 12), with fixed plate of the treadmill (Fig. 8, No. 15) at the beginning and end with the rollers of the device and at high pressure also under direct pressure from the person and when the person starts to walk, the treadmill belt is pressed against each foot with each step, and the rear wheels (Fig. 8 No. 13) start to move.

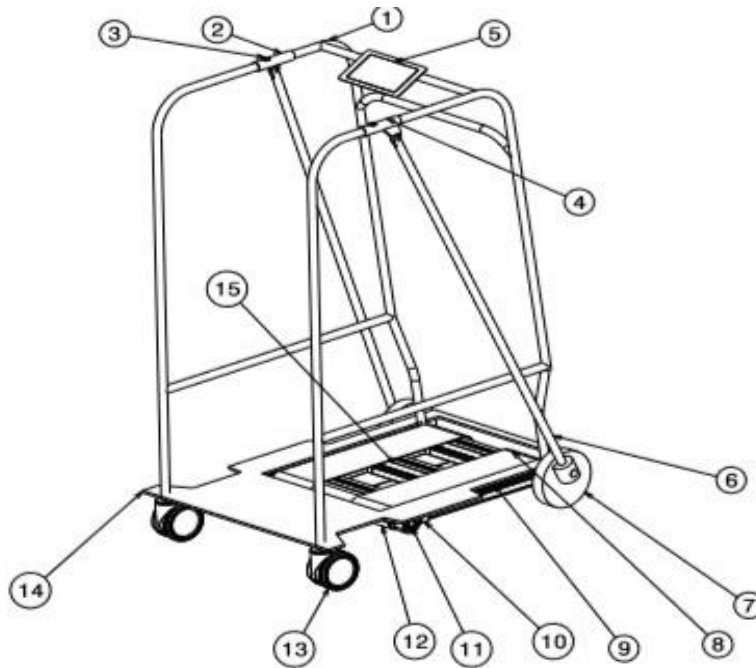

Figure 8: Claims

Discussion

In normal walking there are at least one and at most two legs. But when walking with auxiliary equipment (cane and walker) there are at most three, four and at least one stands. The availability of auxiliary equipment in the lateral transfer market reduces the center of gravity and changes the mechanics of walking. Walking slower and shorter stride lengths in people using assistive devices due to changing long-term walking patterns may have certain effects (e.g. canes and walkers) [12]. As a result, continuous rehabilitation therapy is recommended to reduce these complications.

Using canes and walkers to move gradually reduces the body's mobility and capabilities. People with lower extremity problems, the disabled, and the elderly who use a walker for their movement, tend to be less mobile, and as the fear of falling to the ground gradually increases, the mobility will decrease. It can cause sensory disturbances (tingling and numbness) in the back of the arm, forearm and wrist, and may even cause paralysis of the muscles behind the forearm and wrist drop (inability to straighten the wrist) [13]. But the current walker, due to its stability, creates an inappropriate position on the back and reduces arm rotation. The use of walkers requires more attention than canes.

Currently, due to the general push for the rehabilitation of injured lower extremities in health centers, homes, or sports clubs, conditions require a device such as auxiliary assistants to be designed and constructed to occupy

less space and be more similar to have a normal walk. Not only does this device try to alleviate these effects, but the Walker's section also offers training for the injured person, blood pressure and heart rate, calorie (this part of the device provides the injured person with the ability to when an accident occurs, by pressing the Caller button, it sends a call to the person we defined as Caller and therefore the "caller" is notified of the situation). If the injured person has faced an accident, the location of the person can be precisely defined and found by GPS or the calorie system on the device. The remarkable thing about this device is that, besides the walker part of the device is fixed and moving and it steps like a human (sinusoidal), it can also adjust the height of any user.

Conclusion

The main purpose of this device is to solve the problem of auxiliary displacement devices that have already been introduced. In this sample, the defects of previous devices have been eliminated and are a suitable replacement in the marketplace. Because it was necessary to build a device that performed two treatments simultaneously with different applied workload for a variety of lower limb disabilities and abnormalities (Fig. 9).



Figure 9: Full shape of the machine

Acknowledgment

This device with patent number 97887, in the Office of Industrial Property, Center for Intellectual Property dated 2019 February 6, has been registered.

References

1. Cimet, G., Gencalp, N S., Keskin, G. *Quality of life and job satisfaction of nurses*. J Nurs Care Qual, 2003, 18 (2), 151-158.
2. Kashef, A, Ashourifar, M. *Designing and developing a compartment to use the Human Treadmill as a Rat's Treadmill*. Journal of Advanced Sport Technology, 2018. 2(1):25-29.
3. Borel, L., & Alescio-Lautier, B. *Posture and cognition in the elderly: interaction and contribution to the rehabilitation strategies*. Neurophysiologie Clinique/Clinical Neurophysiology, 2014, 44(1), 95-107.
4. Wollesen, B, Voelcker-Rehage, C. *Training effects on motor-cognitive dual-task performance in older adults*. European Review of Aging and Physical Activity, 2014, 11(1), 5-24.

5. Carpfntfr. M. G. Frank. J. S...Shchir. C. P. & PfySar. G. W. *The influence of postural threat on the control of upright stance*. Experimental Brain Research. 2001, 138.210-218.
6. Rabiei, Mohammad, Farahpour, Nader, Nazem, Farzad, Mehdi Hazavei, Seyed Mohammad. *The effects of long-term use of cane on some kinematic variables of gait in older men*. 6th National Conference of Iranian Students of Physical Education and Sport Sciences. 2010, 11-20.
7. Beurskens, R., & Bock, O. *Age-related deficits of dual-task walking: a review*. Neural plasticity, 2012.
8. Menz, H. B., Lord, S. R., & Fitzpatrick, R. C. *Age-related differences in walking stability*. Age and ageing, 2004, 32(2), 137-142.
9. Jan lee, young. *Health, wellbeing the quality of life: some psychosomatic reflection*. Neuron doctrinal Let; 2004, 24(6), pp.01-403.
10. Changdar, L. *Quality of life in community mental health care*. Journal of Nurse Student, England, 2011, 31(2), 679-683.
11. James, D. *Wearable Technology in sport, a convergence of trends*. Journal of Advanced Sport Technology, 2017, 1(1):1-4.
12. Ostchega, Y., Dillon, C.F., Lindle, R., Carroll, M., Hurley, B.F. *Isokinetic leg muscle strength in older Americans and its relationship to a standardized walk test: data from the national health and nutrition examination survey 1999–2000*. Journal of the American Geriatrics Society, 2004, 52 (6), 977–982.
13. Maki. B. E. Hohiday. P. J. & Topper. A .K. *A prospective study of postural balance and risk of falling in an ambulatory and independent elderly population*. Journal of Gerontology, 1994, 49.M72-84.

Corresponding Author: Sajjad Pashaie, Department of Sport Management, Faculty of Physical Education & Sport Sciences, University of Tabriz, Tabriz, IRAN. **Email:** Sajjad.pashaie@yahoo.com.

طراحی و ساخت دستگاه کمک یار جابجایی مکانیکی - درمانی

سجاد پاشایی*^۱، فاطمه عبدوی^۲، شیرین یزدانی^۳

۱-۲. گروه مدیریت ورزشی، دانشکده تربیت بدنی و علوم ورزشی دانشگاه تبریز، تبریز، ایران

۳. گروه رفتار حرکتی، دانشکده تربیت بدنی و علوم ورزشی دانشگاه تبریز، تبریز، ایران

چکیده

مکانیزم دستگاه کمک یار جابجایی مکانیکی، درمانی، برگرفته از ترمیل، واکر و حرکت های لنگ و کشویی دستی می باشد که فرد بر روی یک اسکلت بندی میله ای فرم مکعبی شکل قرار می گیرد و با حرکت خطی و کشویی (رفت و برگشت) یکی از دسته ها، چرخ های جلو به میزان ۱۸۰ درجه دوران می کند و با حرکت دسته دوم ۱۸۰ درجه باقی مانده دوران روبه جلو انجام می دهد و با حرکت پی در پی بصورت حلزونی دستگاه به جلو حرکت می کند. زمینه فنی اختراع در حوزه مهندسی توانبخشی یا وسایل کمکی افراد مبتلا به ناهنجاری اختلالات حرکتی و معلولین می باشد. چرخ ها حالت الاستیکی و ضربه پذیری دارند و چشم الکترونیکی جلوی واکر در برخورد با موانع ترمز می زند. قسمت تحتانی با مکانیزم اعمال همزمان بارکاری متفاوت برای اندام های تحتانی ترمیمی برای هر پا بصورت مستقل از هم تعبیه شده، که فرد با قدم زدن بر روی آن باعث انتقال حرکت به چرخ های عقب شده و دستگاه به جلو حرکت می کند. این دستگاه علاوه بر سهولت در جابجایی فرد مبتلا به انواع معلولیتی و ناهنجاری های اندام های تحتانی باعث عدم اعمال فشار به ناحیه آسیب دیده در پا یا هر دو پا می گردد.

واژه های کلیدی: ناهنجاری، کمک یار، معلول.