

Effect of aging and manufacturing tolerances on multi-stage transonic axial compressor performance

Author

Hadi Karrabi^a
 Meysam Sajjadi^a
 Mostafa Baghani^{b*}

^a Research and Optimization
 Division at Fartak Company
 (MIDHCO), Tehran, Iran

^b School of Mechanical Engineering,
 College of Engineering, University of
 Tehran, Tehran, Iran

ABSTRACT

The Axial compressor is an integrated part of a gas turbine. The central part of compressors is its blades. Blade aerodynamic has a significant effect on compressor performance. Because of the adverse pressure gradient in the compressor, any deviation in the blade profile has a significant influence on the flow field as well as the compressor performance. During the manufacturing and operation of a compressor, the blade profile may deviate from the nominal design. This deviation may happen within the manufacturing process, e.g., changing in stagger angle of the blade, changing in the maximum thickness of the blade profile or may occur in an operation process, e.g., increasing the blade surface roughness. By the way, these deviations affect the compressor performance. In this research, a numerical investigation is carried out to understand better the effects of geometry variability of the blades, including maximum thickness, blade surface roughness, and rotor blades stagger angle on the Transonic Axial compressor performance parameters, including the efficiency and pressure ratio. A CFD code, which solves the Reynolds-averaged Navier–Stokes equations, is employed to simulate the complicated 3D flow field of the axial compressor. The code is validated against experimental data for the axial compressor. The numerical result is in good agreement with the test data and error at the design point for the efficiency was computed to be 0.3%, which shows high accuracy of the numerical method. Then, the effect of geometry variability on the axial compressor blade performance parameters is studied. Results show that increase in the surface roughness, blade thickness, and the rotor blades twist lowers the efficiency, pressure ratio and mass flow significantly in the compressor. Results show with a 10% increase of the blade installation angle at the design point, the mass flow rate decreases 1.93%, and the efficiency and pressure ratio decreases 0.35% and 1.8%, respectively. The blade surface roughness reduces the mass flow rate, total pressure ratio and efficiency of the compressor. The results show that imposing the roughness at the design point of the compressor, mass flow rate and efficiency is reduced 1.8% and 2.75 %, respectively. Meridional view of this compressor is shown in figure 1 in which the blade profiles for the first to fourth stages are DCA type [1].

Article history:

Received : 1 October 2018

Accepted : 12 December 2018

Keywords: Transonic Axial Compressor, Numerical Simulation, Roughness, Performance Map, Stagger Angle, Efficiency, Twist.

1. Introduction

* Corresponding author: Mostafa Baghani
 School of Mechanical Engineering, College of
 Engineering, University of Tehran, Tehran, Iran
 Email: baghani@ut.ac.ir

Increasing the pressure in a gas-turbine cycle is done by Compressor as one of the most essential components of the Gas Turbines. Transonic axial flow compressors are today

widely used in aircraft and industrial engines to receive at maximum pressure ratios per stage. The compressor consists of several stages of airfoils circumferentially positioned on a rotor driven by a turbine. The purpose of the compressor is to increase the total pressure of the air with minimum power. Axial compressors consume up to 50% of the generated turbine power; therefore, accurate design and manufacturing with minimum deviation and maintaining the compressor at its optimum performance during the operation is of vital importance. Due to the adverse pressure gradient, the flow field inside the compressor is complicated, and because of the duty of the blade for transferring energy to the flow, design of the compressor's blades from the aerodynamic point of view is essential. Compressor performance is entirely dependent on its blade geometry; therefore, any changes in the blade geometry due to the manufacturing process, faulty design or due to the aging of the compressor will influence compressor performance and its efficiency. In this study, the effect of stagger angle and blade thickness change on the compressor performance have been investigated at the rotor blade of the first stage, while the roughness effect is investigated at all stage rotor and stator blades.

Two methods could be employed for this purpose: 1-experimental study 2-Numerical simulation. The cost of the first method is commonly high time-consuming; for this reason, the second method is used in this study.

The meridional view of this compressor is shown in figure 1 in which the blade profiles

for the first to fourth stages are DCA type [1].

Due to complex 3-D geometry, the numerical simulation method needs to be capable of analyzing the 3-D flow field with high precision and without applying any simplification in solving governing equations. The 3-D simulation method, which has high precision in the simulation of the 3D flow field with complex geometry is the answer for the above-mentioned purpose. 3-D numerical models could solve the Navier-Stockx equations without any simplification. Many researchers have simulated the turbo-machines with these numerical methods, and their results are satisfactory, among them are Gu et al. [2], Mugli, F. et al. [3], Cravero, C. and Marini, M [4]. K. L Suder et al has experimentally studied effects of increasing the roughness and the thickness on the rotor of transonic axial compressor. The results showed that increasing the roughness on the rotor surface reduces the compressor performance and increasing the thickness reduces the pressure ratio at the design point by 4%.

The effect of blade lean, twist and bow on the performance of axial turbine at the design point has been investigated by Karroubi et al. [5]. Syverud, E et al. have conducted some experiments on the jet engine GE J85-13. The brine was injected into the axial compressor (with eight stages and 6.5 pressure ratio) of the jet engine and caused fouling on the surface of the blade and, consequently, the surface roughness increased the pressure and suction sides of the blades. Their test results revealed that generally, this roughness caused the performance diagram to shift to the region of the lower flow rate and lower pressure ratio [6].

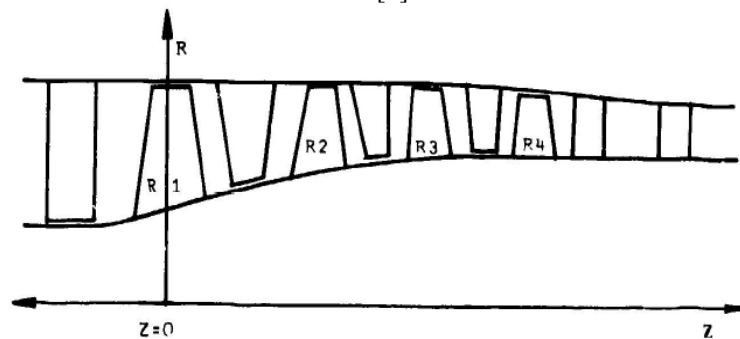

Fig.1. Meridional view OF BBC/SULZER

The effect of roughness on the centrifugal compressor has been investigated by Karrabi et al., and their results showed that the roughness could lead to reducing the efficiency and pressure ratio of the compressor [9].

The impact of blade roughness and biofouling on the performance of a two-bladed horizontal axis marine current turbine was investigated experimentally and numerically. The turbine performance was adversely affected in the case of roughened blades, with the power coefficient (CP) versus λ curve significantly offset below that for the clean case [10].

A series of experimental tests were carried out in the hydraulics laboratory at Cardiff University to assess the influence of blade surface roughness on the performance of vertical axis water turbines [11].

A numerical study of turbulent flow around a HAWT for a range of wind conditions where the flow over the rotor varied from fully attached flow to massively separated flow with the presence of different roughness degrees was performed. The k- ϵ RNG turbulence model was used to close the RANS equations [12].

Marco Montis et al. [13] investigate the influence of trailing edge bleeding on the Aerodynamics of an NGV Cascade experimentally and numerically. They used ANSYS –CFX 11 for numerical simulation, and good agreement between simulation and experimental results is shown.

Nili et al. [14] investigated a centrifugal compressor of a turbocharger numerically. The effects of area ratio, tip clearance, and volute on the performance characteristics was numerically studied and the results validated by experimental data.

Dunn et al. studied a variety of turbulence models via numerical software for a 1.5 stage turbine. The SST turbulence model found to have the most suitable for analysis of secondary flows in comparison with experimental data [15].

Many researchers have investigated how geometric changes in a blade design can affect its performance. Benini et al. [16] investigated the effect of sweep and lean blade on the transonic compressor.

In recent years, several researchers like Marini [17] simulate turbomachines with this method, and they showed good agreement between simulation and experimental results.

In this research, the axial compressor is simulated with the 3-D numerical method, and the results are compared and validated through the experimental data. Next, effects of the first-stage rotor blade twist, the maximum thickness of the first stage of the rotor as well as the roughness of all stages of the rotor and stator on the axial transonic compressor performance map are studied in detail. In the final section, a summary is presented and some conclusions are drawn.

2. Numerical Simulation

The process and the steps of the employed numerical simulation are depicted in Fig.2. The 3-D flow field of four-stage transonic axial compressor is numerically studied in this research.

3. Grid generation

The first and the most crucial step in this simulation are geometry definition and grid generation. This step also is very time-



Fig.2. The General process of the Simulation

consuming. Selection of the grid type and location of the grid refinement is an effective parameter on the results' precision and convergence rate. Grid generation requires high skill, and the user must have a complete physical understanding of the flow field inside the compressor. At the first step, a coarse mesh is used, and after checking the results, mesh refinement has been done. Refinement of the grid must be performed around locations of high gradients of pressure, temperature, velocity, and turbulence. Near the hub, shroud, blade profile, clearance, leading edge, and trailing edge, we have high gradients. In these regions, smaller mesh size should be used. Also, the mesh size depends on the turbulence model. For example, when we employ the SST

(shear stress transport) turbulence model, a mesh size must be used that y^+ value on all the walls is less than 1, but in the k-e model, y^+ value can be around 150. Structured grid and regional blocking are utilized in this work. The geometry, along with the grid, is illustrated in Fig.3.

In theory, the calculation error is expected to be reduced with decreasing the mesh size [9]. To perform mesh study, three mesh sizes are used for estimation of the pressure ratio and efficiency. As could be observed from Figs. 5 and 6, decreasing the mesh size does not affect the computed pressure ratio and efficiency; hence, the mesh size of B grid is acceptable. The isentropic efficiency is defined as

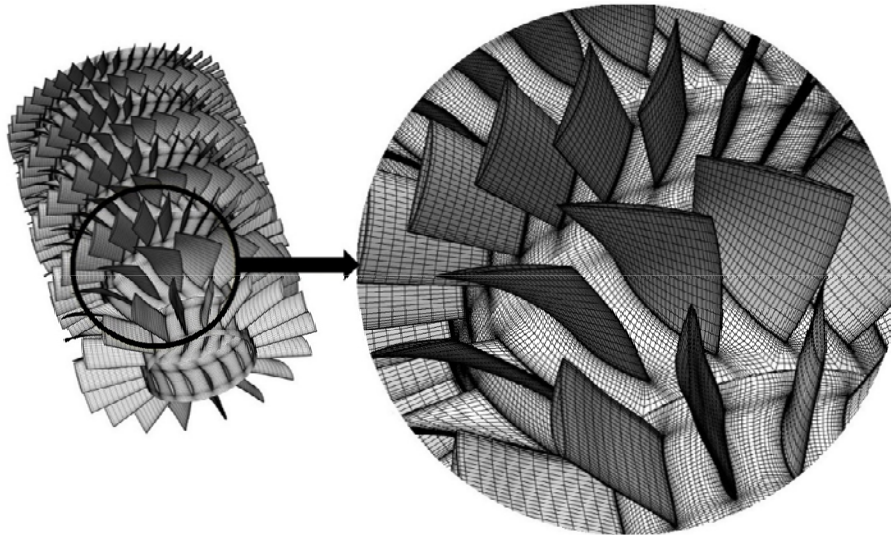

Fig.3. Geometry with a structural grid

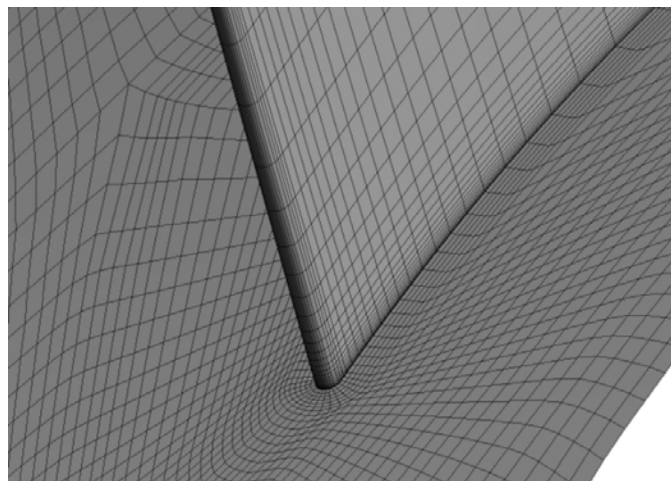

Fig.4. Structural Grid in Meridional Surface

$$\eta_{ic} = \frac{\left(\frac{P_{02}}{P_{01}}\right)^{\frac{k-1}{k}} - 1}{\frac{T_{02}}{T_{01}} - 1}, \quad (1)$$

where, T_{02} is the total temperature at the outlet, T_{01} is the total temperature at the inlet, P_{02} is the total pressure at the outlet and P_{01} is the total pressure at the inlet. The pressure ratio is given by

$$p_r = \left(\frac{P_{02}}{P_{01}}\right). \quad (2)$$

4.Numerical Method

For the flow analysis, the continuity and momentum equations need to be numerically solved. For the compressible flow or flow

together with heat transfer, the Energy equations should be solved as well. The turbulence models must be considered for the turbulent flows. Turbulence equations need to be solved in this work due to the turbulent character of the considered flow field. To properly account for the flow complexity and sharply curved path of the flow, the RNG k-ε turbulence model is selected. This turbulence model has excellent precision and effects while considering sharp changes of the pressure gradients. Using the mixing plane interface model, the computational domain is divided into stationary and moving zones. This model utilizes relative motion between zones to transfer calculated values among them. To complete the model in rotating zones, the Coriolis and centrifugal accelerations are

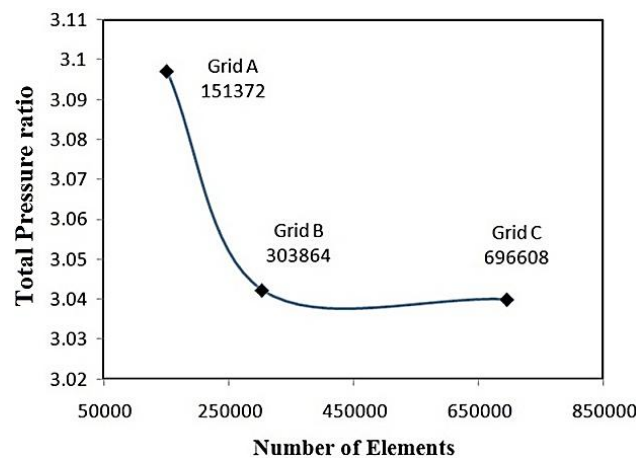

Fig.5. Effect of Grid Size on the Pressure Ratio

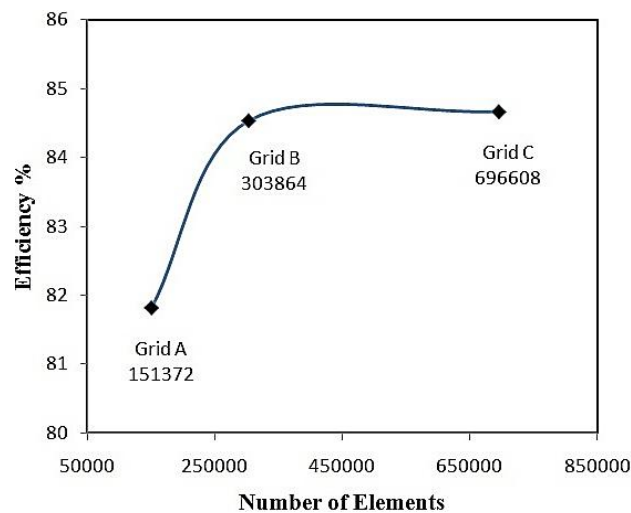

Fig.6. Effect of Grid Size on the Efficiency

added to the momentum equations. The mixing-plane method is a non-physical snapshot approach which cannot be compared to a snapshot of a transient simulation, because the solution does not know anything about what happened before, but it mixes the stator flow into the rotor. The mixing plane model, on the other hand, has the advantage that only one pitch of the stator, as well as the rotor, have to be modeled.

5.Introducing Boundary Conditions

The boundary conditions in this simulation are as follows:

- Stagnation pressure at the compressor inlet is used. Flow direction at the inlet is normal to the inlet cross section and assumed to be without any pre-rotation. Stagnation temperature and the turbulence model are considered as inlet parameters.
- The average static pressure at the outlet is used as the boundary condition in near the choke.
- Mass flow rate at the outlet is used as the boundary condition near the stall.
- The boundary condition of the all stationary and rotating walls is an adiabatic and non-slip condition for velocity on the surface is adopted.
- The interface between rotors and stators is accounted for at the mixing plane.

Due to the axisymmetric condition in the compressor, the periodic boundary condition for the rotor and stator is assumed. In other word, only one blade of the rotor and one blade of the stator in each stage needs to be simulated through applying this boundary condition. Boundary conditions in this simulation are illustrated in Fig.7.

6.Validation of the numerical results

BBC/SULZER axial transonic compressor has four stages with Inlet Guide vane works with air as working fluid. This compressor is designed for the total pressure ratio of 3.06 at 15000 rpm rotational speed [1]. The number of grids in this simulation is 303864, where the mesh independency check is conducted. The results of this simulation are compared with experimental data for this compressor and the profile of the total pressure ratio versus the mass flow rate, and the efficiency versus the mass flow rate is plotted in Figs. 7 and 8, respectively. Error at the compressor design point in the efficiency is 0.3%, which reveals high precision of the utilized computational method.

Comparison between numerical results and experimental data for the radial distribution of the pressure and total temperature from the root to tip of the blade at the compressor outlet for the total pressure ratio of 3.02 is shown in Fig.8.

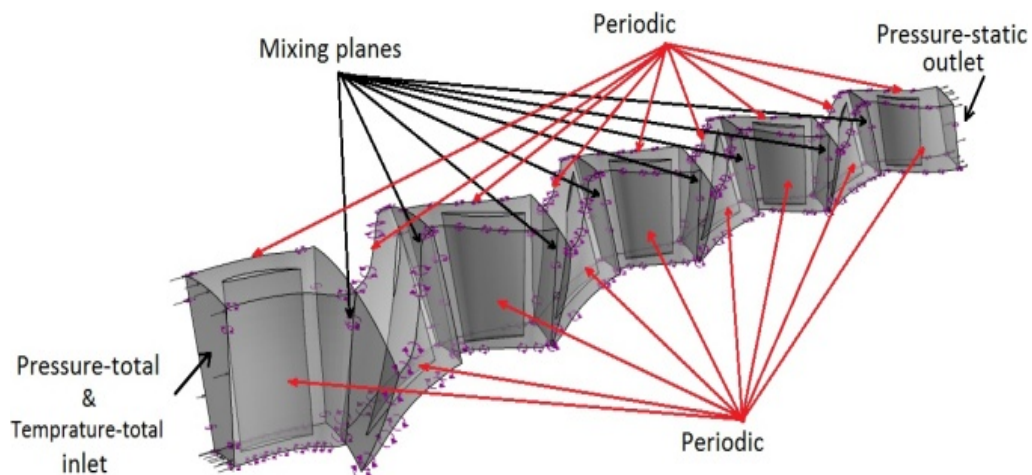

Fig.7. Boundary Conditions used in Simulation

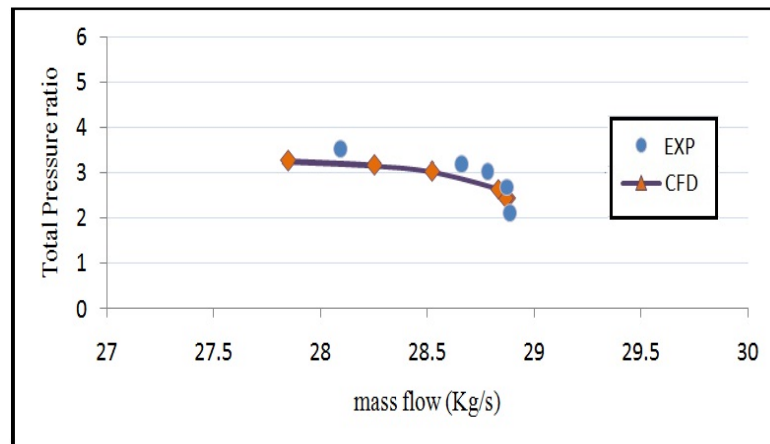

Fig 8. Comparison of the Total Pressure Ratio Between the Experimental and Numerical Results

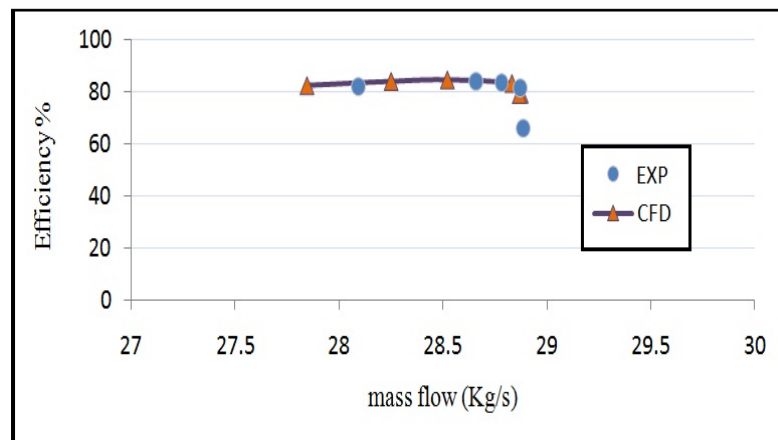

Fig 9. Comparison of the Efficiency Between the Experimental and Numerical Results

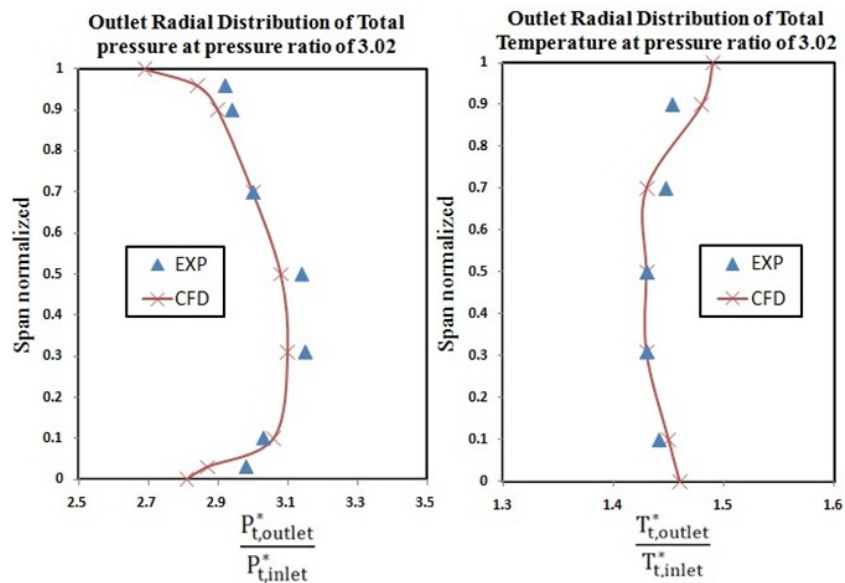

Fig 10. Comparison of the Total Temperature and the Pressure Ratio Between the Experimental and Numerical Results

The simulation results for BBC/SULZER compressor at the design point are presented here. Distribution of the relative Mach number at the root sections, middle and tip of the blade are depicted in Fig.11. At the initial part of the flow path of the rotor blade, relative velocity grows, and this causes a sudden rise in the relative Mach number in this region. As expected, the relative Mach numbers decreases on the pressure side and increases on the suction side. At the start of the suction side for the rotor blades and specifically on the first

stage, relative Mach number will increase over unity, which means the throttle condition for the flow in higher velocity. As it could be observed from Fig.11, with approaching toward the blade tip, the relative Mach number increases and at the blade tip, flow is fully supersonic. Conversely, the flow is sub-sonic at the blade root, which corresponds to the flow nature in the transonic compressors. Total pressure distribution at the root, middle and tip of the blades is shown in Fig.12.

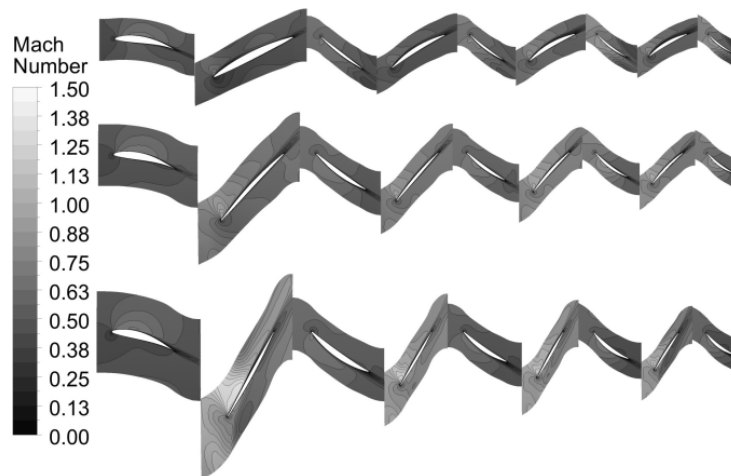

Fig.11 Mach Number at the Root, Middle and Tip of the Blades.

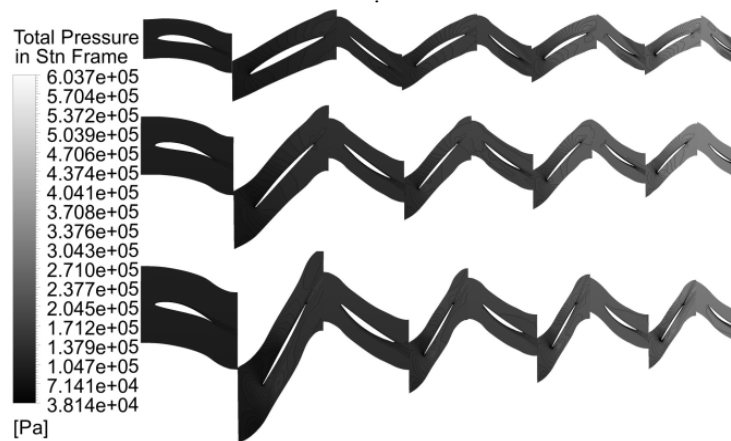

Fig.12. Total Pressure Distribution at the Root, Middle and Tip of the Blades.

As it could be seen from Fig.11, the total pressure increases in the rotor due to the energy transfer into the fluid. However, as one may expect, this value remains constant in stators. Due to the high increase of the relative Mach number at the section close to the rotor blade tip and specifically for the first stage of the rotor blade and due to losses increasing, the total pressure is highly decreased in this region. Streamlines for the flow passing over the rotor blades is shown in general and 3D view of the compressor in Fig.13. Flow velocity is increasing due to flow kinetic energy increasing while passing through the rotor blades. However, the flow velocity decreases on the stator due to the diffusion.

7.Blade twisting

Blade twisting is due to changing of the stage angle in the manufacturing process for the

blades. The stager angle changes linearly from the root to the tip. As could be observed from Fig.14, these changes start from the root and increase linearly to the tip and at the tip reaches its maximum deviation value, which is 10%.

Results of the blade twisting in the pressure ratio-flow rate and efficiency-flow rate are shown in Figs 15 and 16, respectively. With a 10% increase of the blade installation angle at the design point, the mass flow rate decreases 1.93% and the efficiency and pressure ratio decreases 0.35% and 1.8%, respectively. With increasing the installation angle, the throat area decreases, and consequently, the flow rate decreases. With a 10% decrease in the installation angle, the flow rate increases 2.21% and efficiency, and the pressure ratio increase 1.16% and 0.53%, respectively.

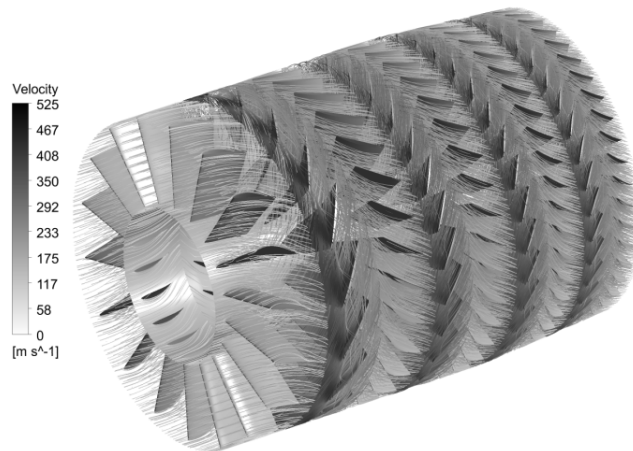

Fig 13. Streamline in 3d Views

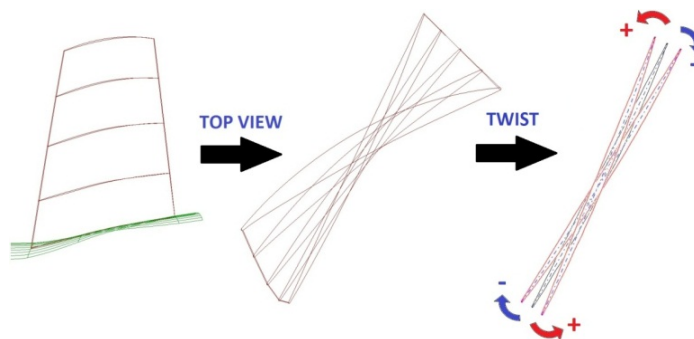

Fig.14. Twist Angle Definition and Implementation

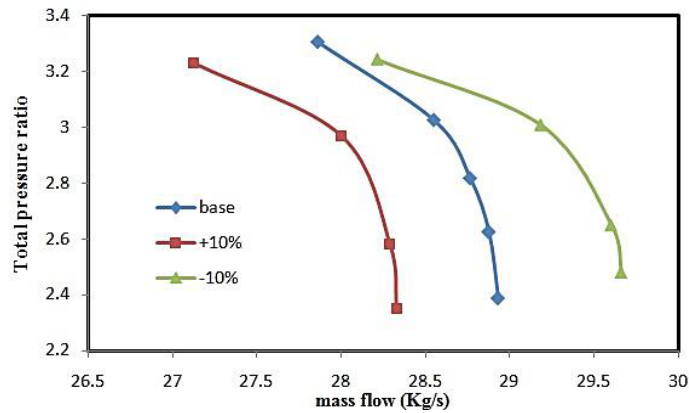

Fig 15. Effect of the Blade Twist on the Total Pressure Ratio

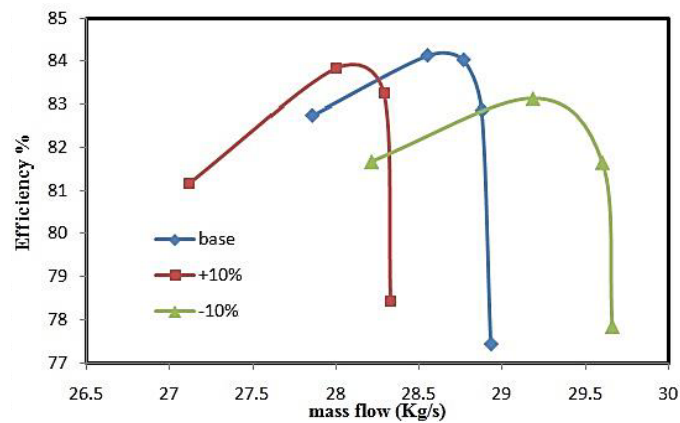

Fig 16. Effect of the Blade Twist on the Efficiency

Deviation of the stager angle from its nominal value changes the incidence angle from its design value. Designed incidence angle is an optimum value which causes the minimum total pressure loss, and its variation will increase the pressure loss and efficiency as

well. According to Fig.17, the variation of the incidence angle from its design value increases the total pressure loss [13] and decreases both the efficiency and pressure ratio of the compressor. The results of changing the stager angle prove the discussed efficiency reduction.

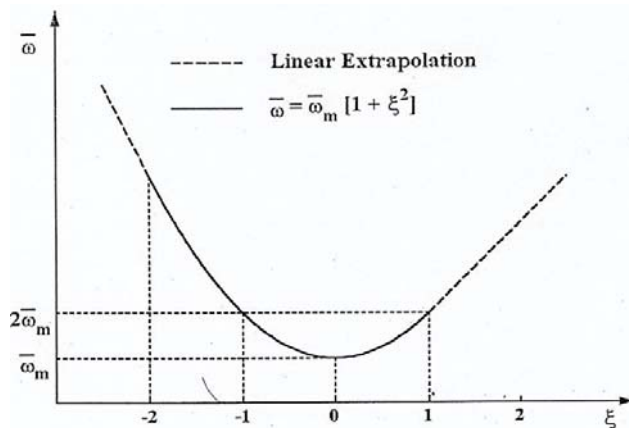

Fig.17. Effect of Non-Dimensional Incidence Angle on the Loss

8.Change in maximum thickness of the first rotor blade

Change in maximum thickness of the blade could happen during the blade manufacturing process. Maximum thickness change may affect compressor performance. To account for this effect, this has been imposed on the geometry and has been simulated in 3-d numerical modeling. Changing in maximum thickness is imposed through two values. The first change is an increase of the maximum thickness of all the span first stage blade of the rotor to 10 percent against the nominal value, and the second change is a decrease of the maximum thickness of all the span first stage blade of the rotor to 10 percent against the nominal value. The method for geometry changing is shown in Fig.18.

The effects of changing the maximum thickness on the efficiency and pressure ratio are shown in Figs.19 & 20. Blockage is one of the most critical dynamic phenomena that has a high effect on axial compressor performance. Because of an increase in the maximum thickness, adverse pressure gradient along the blade profile has been enhanced, and due to this, the boundary layer near the blade profile grows higher, therefore, the effective area between the blades for crossing the flow has been decreased, which leads to a reduction in the mass flow rate. This phenomenon is named blockage. Blockage phenomenon increases the loss and therefore, lowers the efficiency and the pressure ratio. At the compressor design point, with a 10 percent increase in the

maximum thickness, the mass flow rate is decreased by 0.4%, and the efficiency is decreased by 0.1%. While the maximum thickness is lowered by 10%, the mass flow rate and efficiency are increased by 0.5% and 0.9%, respectively. The results show that in constant mass flow rate, with increasing the maximum thickness, the pressure ratio is decreased and with decreasing the maximum thickness, the pressure ratio is enhanced.

Blade roughness is one of the main reasons for the compressor performance deterioration. Due to many factors, blade roughness may occur. One of the main factors of blade roughness is aging. Compressor aging depends on installation location as well as the climate and could be different from site to site. In industrial sites, the compressor entrance air can consist of particles of oil and dust. When these particles enter into the compressor, they may lead to foul. Deposits of the oil, dust, grease and other materials may roughen the compressor surfaces. Blade roughness can affect the compressor flow field. When the blade roughness grows, the thickness of the boundary layer grows faster and hence leading to an increase in losses. Roughness causes skin friction to rise and, therefore, more loss. Also, the higher surface roughness may cause narrowing in the operating range through the early onset of the stall and surge. Reducing the mass flow rate is another result of the roughness; roughness enhances the boundary layer thickness both on the blades and along the end walls of the annulus and hub, and leads to a reduction of the flow area;

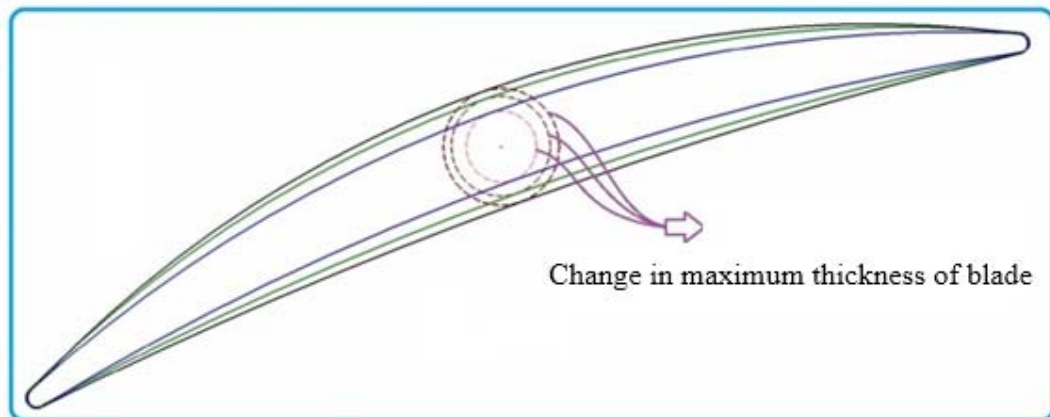

Fig.18. A Method for the Geometry Changing

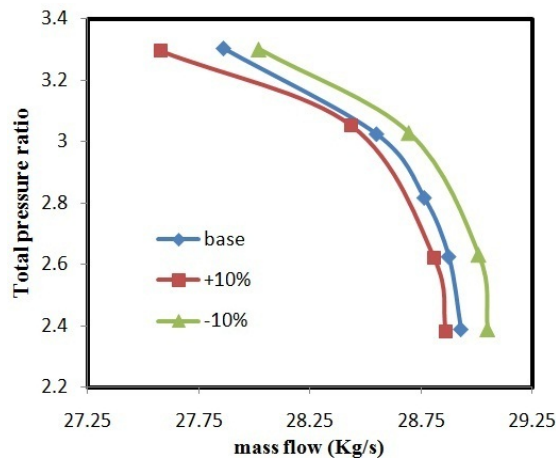

Fig.19. Total Pressure Ratio Vs. the Mass Flow

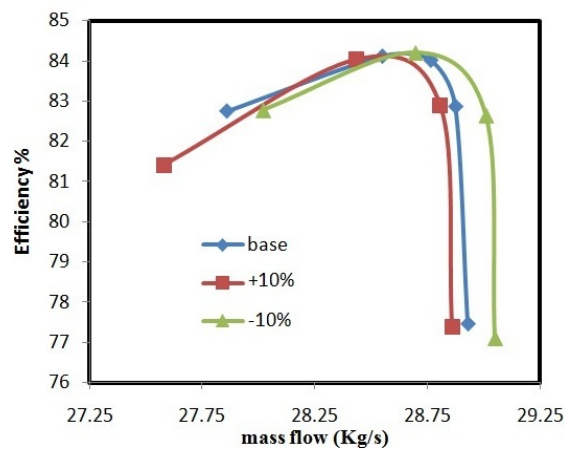

Fig.20. Isentropic Efficiency Vs. the Mass Flow

therefore, the mass flow rate is reduced. The first stages of an axial compressor are normally the ones that are heavily roughed. For this reason, in this study, changes in the roughness of the compressor are assumed to be linear. First stage roughness is high, and roughness of the end stage is low. For modeling the roughness in the numerical code, the logarithmic overlap layer begins to deviate from that of the smooth wall by Δu^+ . The Δu^+ is usually modeled as a function of the roughness Reynolds number, k^+ . Quantities u^+ , Δu^+ and k^+ are, respectively, as

$$u^+ = \frac{1}{k} \ln y^+ + B - \Delta u^+ \tag{5}$$

$$\Delta u^+ = \frac{1}{k} \ln(1 + 0.3k^+) \text{ and} \tag{6}$$

$$k_{eq}^+ = U_\tau \frac{k_{eq}}{\nu} \tag{7}$$

There exist three roughness regimes corresponding to k^+ [14]:

- $k_{eq}^+ \leq 5$ Hydraulically smooth wall
- $5 \leq k_{eq}^+ \leq 70$ Transitional roughness regime
- $70 \leq k_{eq}^+$ Fully rough flow

The main reason of exercising roughness effects is to employ modified wall functions instead of the original ones. There are some suggestions for near-wall grid spacing when the wall is rough. Wilcox suggested using a relatively large grid element size adjacent to a boundary. "Large" means covering the region of rapid variation in turbulence variables and relying on the wall function to set the proper average values in this region. In this study, the

first grid size near the wall is set to be in the order of the roughness height. Roughness value on the inlet guide vane is assumed 150 micrometers and reduced linearly along the compressor so that at the last stator, the roughness is 75 micrometers. Effect of the roughness on the performance is illustrated in Figs. 21 & 22. Result of the roughness is an increase of the boundary layer thickness that leads to a blockage in the flow. The mass flow rate through the compressor is reduced, and the relevant performance curve of the compressor is shifted to the lower mass flow rate. As the results show, the blade surface roughness reduces the mass flow rate, total pressure ratio and efficiency of the compressor. The operation range (the range between the surge and choke) is also decreased. The results show

that imposing the roughness at the design point of the compressor, mass flow rate, and efficiency is reduced by 1.8% and 2.75 %, respectively.

9. Summary and Conclusions

3D simulation flow in an axial compressor was implemented, and effects of the blades' geometrical changes, including changes of the stager angle on the compressor performance were studied. For validation purposes, the results of 3D numerical solution were compared with experimental data, and the error at the design point for the efficiency was computed to be 0.3%, which shows high accuracy of the numerical method. The rotor blade twist, including the blade stager angle on

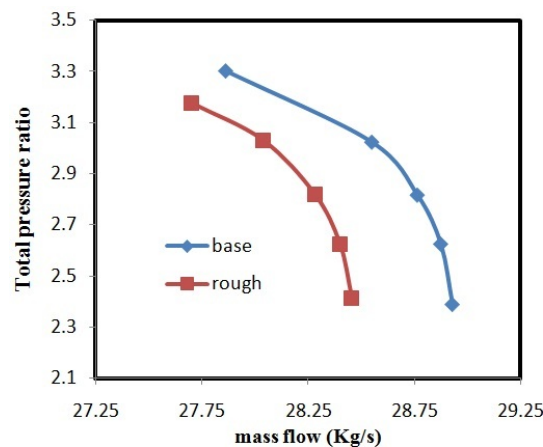

Fig.21. Total Pressure Ratio Vs. Mass Flow

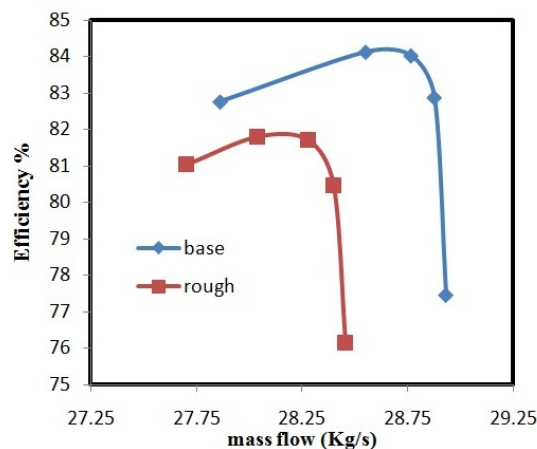

Fig.22. Isentropic Efficiency Vs. the Mass Flow

the first-stage rotor blade, was changed, and its effects were studied accordingly. The results of 3D numerical solution revealed that due to increasing of the blade stager angle, the performance diagram shifted toward the lower pressure ratio and the lower efficiency, and with decreasing this angle the diagram shifts toward the higher flow rate and the lower efficiency and pressure ratio. Efficiency is reduced due to increasing the losses in both cases of increasing and decreasing the angle.

References

- [1] Hirsch, Ch., Denton, J. D., "Propulsion and Energetic panel working group 12 on Through flow calculations in Axial Turbomachines", AGARD Advisory Report No.175, Advisory group for Aerospace research and development. ADA109292, 1981.
- [2] Gu, F., Engeda, A., Cave, M. and Di Liberti, L., "A Numerical Investigation on the Volute/Diffuser Interaction Due to the Axial Distortion at the Impeller Exit," Transactions of the ASME, Journal of Fluid Engineering, Vol. 123, no. 3, pp. 475-483, 2001.
- [3] Mugli, F., Holbein, P. and Dupont, P., "CFD Calculation of a Mixed Flow Pump Characteristic from Shut-off to Maximum Flow", in Proc. ASME Fluid Engineering Division Summer Meeting (FEDSM'01), New Orleans, LA, USA, paper FEDSM2001-18072, May-June 2001.
- [4] Cravero, C. and Marini, M., "Modeling of Incompressible Three-Dimensional Flow in Rotating Turbomachinery Passages", in Proc. ASME Fluids Engineering Division Summer Meeting (FEDSM'02), Montreal, Quebec, Canada, paper FEDSM2002-31177, July 2002.
- [5] K. L. Suder, R. V. Chima, A. J. Strazisar, W. B. Roberts, "The Effect of Adding Roughness and Thickness to a Transonic Axial Compressor Rotor", Journal of Turbomachinery. Vol. 117/491, 1995.
- [6] Syverud, E., Brekke, O., and Bakken, L. E., "Axial Compressor Deterioration Caused by Saltwater Ingestion", ASME J. Turbomach., 129, pp. 119-127, 2007.
- [7] Ferziger, J.H. and Peric, M., "Computational Methods for Fluid Dynamics", Springer, Berlin, Germany, 1996.
- [8] ANSYS CFX-11 User's Guide
- [9] Budugur Lakshminarayana, "Fluid dynamics and Heat transfer of Turbomachinery", John Wiley & Sons Inc, ISBN 0-471-85546-4, 1996.
- [10] Jessica M., Walker, Karen, A., Flack, Ethan E., Lust, Michael P., Schultz and [Lukša Lužnik](#), "Experimental and numerical studies of blade roughness and fouling on marine current turbine performance" Renewable Energy, Volume 66, June 2014, Pages 257-267
- [11] Luis Priegue and Thorsten Stoesser "The influence of blade roughness on the performance of a vertical axis tidal turbine" International Journal of Marine Energy, Volume 17 (2017), Pages 136-146
- [12] [Bouhelal Abdelhamid](#), [Arezki Smaili](#), Christian Masson and [Ouahiba Guerri](#) "Effects of Surface Roughness on Aerodynamic Performance of Horizontal Axis Wind Turbines" The 25th Annual Conference of the Computational Fluid Dynamics Society of Canada, CFD2017-337, 18-21 June 2017, University of Windsor.
- [13] Marco Montis, Reinhard Niehuis, Mattia Guidi, Simone Salvadori, Francesco Martelli, and Bruno Stephan 2009, "Experimental and Numerical Investigation on the Influence of Trailing Edge Bleeding on the Aerodynamics of a NGV Cascade", in Proc. ASME Turbo Expo, GT 2009-59910.
- [14] Nili-Ahmadabadi M., Hajilouy-Benisi A., Durali M., F. Ghadak., 2008 "Investigation of a Centrifugal Compressor and Study of the Area Ratio and Tip Clearance Effects on Performance" Journal of thermal science.
- [15] Dwain. D, Glen S. 2009, "Turbulence Model Comparisons for a Low Pressure 1.5 Stage Test Turbine" ISABE-2009.
- [16] Benini, B., Biollo, R., 2007, "Aerodynamics of swept and leaned transonic compressor-rotors", Journal of Applied energy pp. 1012-1027

- [17] Mugli, F., Holbein, P. and Dupont, P., May-June 2001, "CFD Calculation of a Mixed Flow Pump Characteristic from Shut-off to Maximum Flow," in Proc. ASME Fluid Engineering Division Summer Meeting (FEDSM'01), New Orleans, LA, USA, paper FEDSM2001-18072.
- [18] Roland. H. Aungier, 2003, " Axial Flow Compressors: A Strategy for Aerodynamic Design and Analysis ", American Society of Mechanical Engineers, ISBN-10: 0791801926.