

Phthaloylation of Cellulose Acetate in Acetic Acid and Acetone Media

Niculae Olaru* and Liliana Olaru

Institute of Macromolecular Chemistry "Petru Poni"
Aleea Gr. Ghica-Voda, 41 A, Iasi-700487, Romania

Received 3 April 2005; accepted 17 November 2005

ABSTRACT

A study of the phthaloylation of cellulose acetate in two reaction media consisting of acetic acid and acetone, respectively is performed by using a statistical experimental design. Two kinds of cellulose acetate having degrees of acetylation of 1.62 and 1.93, respectively are used as starting materials. Two mathematical models are obtained for describing the correlation between the degree of phthaloylation of the synthesized cellulose acetate phthalates and the principal reaction parameters involved: the molar ratios of catalyst/cellulose acetate and phthaloylation agent/cellulose acetate. It is concluded that the degree of phthaloylation of the products is mainly influenced by the amount of phthaloylation agent in the case of acetic acid and by the amount of catalyst in the case of acetone used as organic solvent.

Key Words:

cellulose acetate;
phthaloylation;
degree of substitution;
mathematical models.

INTRODUCTION

Cellulose acetate phthalate (CAP) is the mixed ester of cellulose with *o*-phthalic and acetic acids which proves interesting properties that make it suitable for enteric film coating of capsules and tablets [1]. Recent reports have described its

ability to inhibit infections by the human immunodeficiency virus type 1 (HIV-1) and several herpes viruses in vitro [2-6]. Composite biofilms produced using wheat gluten and cellulose acetate phthalate are cited as barriers to moisture and oxygen

(*)To whom correspondence should be addressed.
E-mail: nolaru@icmpp.ro

diffusion [7].

CAP is a nontoxic and inexpensive material and has been used for several decades as a pharmaceutical excipient due to its solubility dependent on the pH of the aqueous media. Thus, enteric coatings based on CAP are resistant to acidic gastric fluids, but easily soluble in mildly basic medium of the small intestine. The pH-sensitive solubility of CAP is mainly determined (as other properties of this mixed ester) by the degree of substitution (DS), namely the average number of substituent groups bound to an anhydroglucose unit (AGU), as well as by the molar ratio of the substituents (acetyl and phthaloyl groups). These two structural characteristics of the polymer are dependent on its provenience, i.e., on the method employed for its synthesis.

The most common way to prepare cellulose acetate phthalate consists of the reaction of a partially substituted cellulose acetate (CA) with phthalic anhydride in the presence of an organic solvent and a basic catalyst, following the Scheme I. DS_{ac} and DS_{ph} are the average number of acetyl and phthaloyl groups on AGU, respectively.

The organic solvents widely used as reaction media for the phthaloylation of cellulose acetate are acetic acid, acetone, or pyridine. The basic catalysts employed are anhydrous sodium acetate when using acetic acid, amines when using acetone, and the organic solvent itself when using pyridine as reaction medium. Data reported so far on various procedures to obtain CAP with appropriate characteristics suitable for above mentioned purposes are convincing arguments

for the main factors involved in these processes: the structural characteristics of the starting cellulose acetate (both DS_{ph} and DS_{ac} and also the distribution of substituents on AGU), the nature of the organic solvent used as reaction medium and the reaction parameters such as temperature, reaction time, and composition of the reaction system [8-10].

The influence of the reaction parameters on the evolution of the process has been investigated by varying successively one of them while maintaining the others at constant values. Such approach is time consuming and cannot prove possible interactions between two or more variables.

The present paper has as principal goal, the study of phthaloylation of cellulose acetate in media of acetone and of acetic acid. We restarted to statistical experimental design in order to obtain adequate mathematical models for describing the relation between the average number of phthalol group bound to anhydroglucose unit of cellulose acetate, on the one hand, and the principal reaction parameters, the amounts of catalyst, and of phthaloylation agent, on the other hand. By simultaneous variation of these parameters, this approach may evidence the separate effect of each of them and their possible interactions.

EXPERIMENTAL

Materials

All chemicals used for experiments: acetic acid, acetone, phthalic anhydride, sodium acetate, triethylamine,

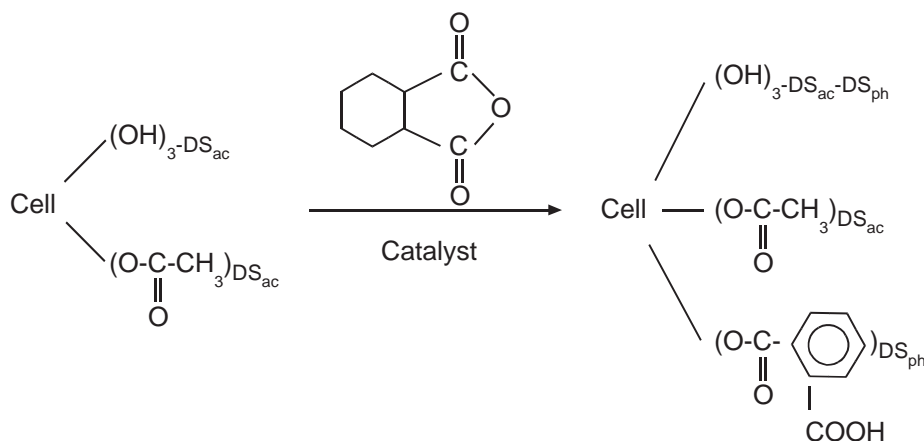

Scheme I

sulfuric acid, sodium hydroxide, hydrochloric acid, were of reagent grade and supplied by "Reactivul" in Bucharest.

Synthesis of polymers was performed using laboratory glass vessels. The reactions were carried out in a glass reactor equipped with a glass stirrer and placed in a water bath in order to control the required temperature. After the desired reaction time elapsed, the polymer solution was slightly poured into a large glass containing distilled water in order to precipitate the polymer. Separation of the solid phase was accomplished by vacuum filtration on a Büchner funnel and purification of the solid product was realized by repeated washings with distilled water until the washing water was neutral. Thereafter, the polymer was dried at room temperature.

The amounts of polymers and chemicals involved in syntheses were chosen so as to correspond to the specification given below for each polymer.

CA Synthesis

Cellulose acetates with different DS values were prepared by hydrolysis of high-acetyl cellulose ($DS = 2.91$) at 40°C in aqueous acetic acid using sulfuric acid as a catalyst (10 % wt with respect to the starting CA). The proportion of the starting polymer in the reaction mass was 10 % wt. Various proportions of water in acetic acid were used (10, 20, and 25 % by weight) in order to obtain different amounts of free OH groups bound to the primary carbon atom of AGU, following the conventional procedure known from literature [11].

CAP Synthesis

Cellulose acetates used for CAP synthesis had different DS values: 0.5, 1.30, 1.62, 1.93, and 2.53. Cellulose acetates were phthaloylated with phthalic anhydride in two organic media: acetic acid and acetone using anhydrous sodium acetate and triethylamine (TEA), respectively, as basic catalysts.

Phthaloylation of CA in acetic acid was performed at 70°C for 4 h. The viscous solution of CAP thus obtained was diluted with an aqueous solution of acetic acid 75 % wt. The polymer was separated from this solution by precipitation into cold water, then it was filtered on a Büchner funnel and purified by washing with distilled water until the wash liquid was free of acidity. Finally, the product was air-dried.

CAP synthesis in acetone medium followed a simi-

lar procedure, at 56°C for 4 h. The precipitation of the product was realized in warm water (about 60°C) in which a solution of hydrochloric acid (10 % wt) was added in a sufficient amount so as to completely neutralize the basic catalyst used for phthaloylation. Washing of the obtained polymer was performed with warm and cold water until neutral pH was achieved.

CA and CAP Characterization

The degree of acetylation of CA samples (DS_{ac}) was determined by the usual saponification method [12]. The degree of phthaloylation of CAP (DS_{ph}) was determined by titration of carboxyl groups with sodium hydroxide according to the known procedure [13].

RESULTS AND DISCUSSION

In our preliminary studies we were interested in gathering some information about the influence of DS of the starting CA, and the conditions of hydrolysis of highly acetylated cellulose acetate for preparation of starting CA, on DS_{ph} . In this sense, a series of four samples of CA having different DS_{ac} and another serie of three samples of about the same DS_{ac} but obtained from high DS cellulose acetate by hydrolysis in different aqueous acetic acid media have been selected and phthaloylated in acetone media.

The first set of four starting CAs samples was phthaloylated at 56°C for 4 h at molar ratios of phthalic anhydride/CA and TEA/CA of 2.4 and 2, respectively. The characteristics of the starting CA and of the resulted products as well as the aspect of reaction system are presented in Table 1.

It is observed (Table 1) that CAs with DS_{ac} of 0.50 and 2.53 led to CAPs with about the same DS_{ph} but

Table 1. Phthaloylation of CA with different DS values in acetone medum.

DS_{ac}	Reaction system aspect	DS_{ph}	Solubility in NaOH solution (1 N)
0.50	Heterogeneous	0.36	Insoluble
1.30	Quasi-homogeneous	0.91	Soluble
1.92	Quasi-homogeneous	0.93	Soluble
2.53	Homogeneous	0.33	Soluble

insoluble and soluble in 1N NaOH aqueous solution, respectively. Therefore, in heterogeneous systems, although a lot of hydroxyl groups on AGU are free, but, a small proportion of them are accessible and available for phthaloylation reaction. CAs with DS_{ac} of 1.30 and 1.92 led to soluble end products with a substantially higher DS_{ph} . Therefore, this range of DS_{ac} for starting CA can be adequate to the synthesis of CAP in acetone media, although the reaction systems are not completely homogeneous.

The second set of experiments used three samples of CA (DS_{ac} about 1.90) obtained by hydrolysis of highly acetylated cellulose in 15, 20, and 25 % wt aqueous acetic acid, respectively, using sulfuric acid as catalyst. Phthaloylation was performed at molar ratios of phthalic anhydride/CA of 1.8 and TEA/CA of 1. CA obtained by hydrolysis in 15% aqueous acetic acid led to a $DS_{ph} = 0.51$ and those obtained in 20% and 25% aqueous acetic acid led to a $DS_{ph} = 0.62$. It is well known that the presence of more water in the hydrolysis medium determines a higher proportion of free OH groups bound to C6 atom of AGU. Therefore, more free OH groups on C6 favor the phthaloylation process.

In our further study, two samples of CA: $DS_{ac} = 1.62$ and $DS_{ac} = 1.93$, obtained by a hydrolysis process in 20 % wt aqueous acetic acid (in order to provide a higher proportion of free OH groups on C6 atom) were used for phthaloylation in media of acetic acid and acetone, respectively.

For a systematical study of the influence of proportions of the phthaloylation agent and of the catalyst on DS_{ph} of CAP we resorted to a second-order rotatable experimental design [14-16]. With second order rotatable design, no replication is needed in order to find the error mean square. This can be done by replicating the center point. The polynomial equation for such a statistical approach is:

$$Y = b_0 + b_1 x_1 + b_2 x_2 + b_{12} x_1 x_2 + b_{11} x_1^2 + b_{22} x_2^2 \quad (1)$$

where Y is the degree of phthaloylation (DS_{ph}) and x_1 , x_2 are the independent variables. This regression equation was tested for the fit adequacy as follows [17].

The residual sum of squares is calculated,

$$S_1 = \sum_{i=1}^N (Y_i - \hat{Y}_i)^2$$

for which, the number of degrees of freedom is $f_1 = N - L$, where N is the number of experiments and L is the number of terms in equation (1). From the n_0 repeated observations at the center point we find the error sum of squares:

$$S_2 = \sum_{i=1}^{n_0} (Y_{0i} - \bar{Y}_0)^2$$

for which the number of degrees of freedom is:

$$f_2 = n_0 - 1$$

The inadequacy of fit sum of squares is then:

$$S_3 = S_1 - S_2$$

for which the number of degrees of freedom is given by:

$$f_3 = f_1 - f_2$$

Then an F-test is calculated to test the fit adequacy:

$$F = (S_3/f_3)/(S_2/f_2)$$

which is compared with the tabulated value for a certain value of the significance level p, $F_p(f_3, f_2)$. The estimated regression equation fits the data adequately if $F < F_p(f_3, f_2)$.

The significance of the estimated coefficients is tested by calculating the Student *t*-test and comparing it with the tabulated value for a significance level p and for N-L degrees of freedom. If the calculated values are higher than the tabulated ones, the coefficients are significant for the corresponding p and N-L. For significance levels of 0.05 and 0.01, the tabulated values of *t* for 7 degrees of freedom, are 2.365 and 3.499, respectively, and for 9 degrees of freedom are 2.262 and 3.250, respectively, .

The independent variables chosen in our study were the molar ratio of catalyst / CA (x_1) and the molar ratio of phthalic anhydride / CA (x_2).

These independent variables and the region covered by the experiments performed in acetic acid are presented in Table 2 and the correspondence between the coded x-scales and the original ones for the same system is given in Table 3.

The matrix of x-variables for such a design

Table 2. The region covered by the experiments for the phthaloylation of CA in acetic acid medium.

Independent variables	Notation	Range of variation
Sodium acetate (catalyst)/CA (mol/mol)	x_1	0.61-2.19
Phthalic anhydride/CA (mol/mol)	x_2	0.61-2.81

includes six columns headed x_0 , x_1 , x_2 , x_1^2 , x_2^2 , and x_1x_2 and 13 rows corresponding to the 13 experiences needed. The columns headed x_1 and x_2 specify the combinations to be used and constitute the plan for the experiment. For this reason, in Table 4 just these two columns have been retained beside the columns of the experimental (Y_{exp}) and calculated (Y_{calc}) responses and those of deviations (ΔY) and relative errors (ϵ_r).

The regression coefficients of equation (1) are then obtained by the known equations [14]:

$$Y = 0.688 + 0.053 x_1 + 0.13 x_2 - 0.005 x_1^2 - 0.038 x_2^2 + 0.007 x_1 x_2 \quad (2)$$

(16.33) (40.198) (1.515)
(10.894) (1.641)

$$S_1 = 0.00058471, f_1 = 7; S_2 = 0.00048, f_2 = 4; S_3 = 0.0001, f_3 = 3; F = 0.27775; R^2 = 0.997$$

$F_{p=0.01}(3, 4) = 16.69$, therefore $F < F_{p=0.01}(3, 4)$ and the estimated regression equation fits the data adequately. The value of the square multiple correlation coefficient, R^2 , shows that 99.7 % of the sum of squares of deviations of Y from its mean is attributable to the regression.

However, the calculated values of Student t -tests, in parentheses under regression coefficients, show that terms in x_1^2 and x_1x_2 are insignificant for a significance level of $p=0.05$ and therefore are removed from equation (2). After removal of insignificant coefficients, the regression equation takes the form:

$$Y = 0.684 + 0.053 x_1 + 0.13 x_2 - 0.037 x_2^2 \quad (3)$$

(14.149) (34.828) (9.348)

$$S_1 = 0.0010017, f_1 = 9; S_2 = 0.00048, f_2 = 4; S_3 = 0.0005217, f_3 = 5; F = 0.8695; R^2 = 0.994$$

$F_{p=0.01}(5, 4) = 15.52$, therefore $F < F_{p=0.01}(5, 4)$ and

Table 3. The correspondence between the coded x-scales and the original ones for the experiments carried out in acetic acid medium.

Coded scales of independent variables	Original scales of independent variables	
	x_1	x_2
-1.414	0.61	0.61
-1	0.84	0.93
0	1.40	1.71
+1	1.96	2.49
+1.414	2.19	2.81

the estimated regression equation fits the data adequately.

The value of the square multiple correlation coefficient, R^2 , shows that 99.4 % of the sum of squares of deviations of Y from its mean is attributable to the regression.

As the calculated t -test values indicate, the regression coefficients are substantially non-zero for a significance level of 0.01 and the most important terms are those in x_2 and x_1 .

Therefore, the obtained equation (3) describes adequately the response surface in the experimental range.

Table 4. Experimental results and calculated values with equation (3) for the phthaloylation of CA in acetic acid medium.

Sample	x_1	x_2	Y_{exp}	Y_{calc}	ΔY	ϵ_r (%)
1	-1	-1	0.47	0.47	-0.01	1.15
2	1	-1	0.56	0.57	0.01	1.81
3	-1	1	0.72	0.72	0.00	0.61
4	1	1	0.84	0.83	-0.01	1.20
5	-1.414	0	0.60	0.61	0.01	1.62
6	1.414	0	0.75	0.76	0.01	1.20
7	0	-1.414	0.43	0.43	-0.00	0.81
8	0	1.414	0.79	0.79	0.00	0.49
9	0	0	0.69	0.68	-0.01	0.82
10	0	0	0.67	0.68	0.01	2.14
11	0	0	0.70	0.68	-0.02	2.24
12	0	0	0.69	0.68	-0.01	0.82
13	0	0	0.69	0.68	-0.01	0.82

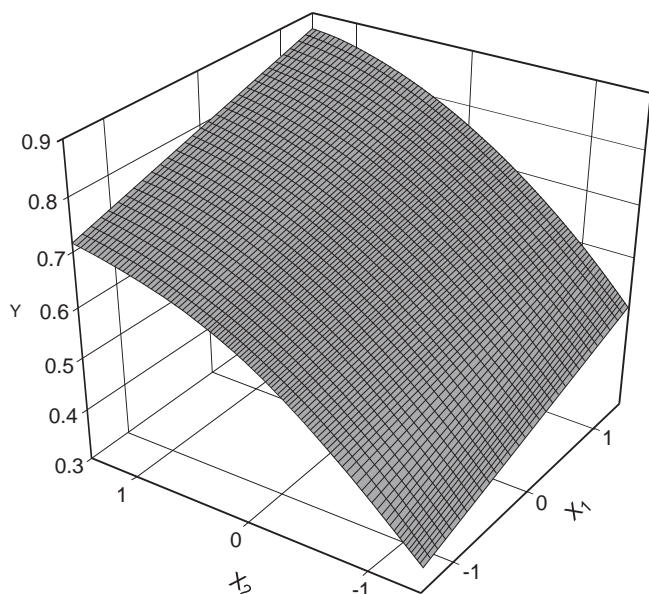

Figure 1. Dependence of DS_{ph} (Y) on molar ratios of catalyst /CA (x_1) and phthalic anhydride/CA (x_2) for the phthaloylation of CA in acetic acid medium.

The independent variables (x_1 , x_2) in coded values, the experimental (Y_{exp}) and calculated (Y_{calc}) with the obtained equation (3) values of DS_{ph} of the obtained CAP samples, as well as deviations (ΔY) and relative errors (ϵ_r) for these experiments are presented in Table 4. ΔY and ϵ_r were calculated as follows: $\Delta Y = Y_{exp} - Y_{calc}$, and $\epsilon_r = \Delta Y \times 100 / Y_{exp}$, respectively. Relative errors are presented as absolute values and are smaller than 2.5 %.

Visualization of the response surface is presented in a three-dimensional space in Figure 1. From this picture it is evident that DS_{ph} (Y) increases with the increasing of molar ratios of both catalyst / CA (x_1) and phthaloylation agent / CA (x_2), but the influence of the latter one is more pronounced.

The same statistic interpretation was performed for the experiments realized with acetone as reaction medium and data similar to those presented in Tables 2-4 are

Table 5. The region covered by the experiments for the phthaloylation of CA in acetone medium.

Independent variables	Notation	Range of variation
Triethylamine (catalyst)/CA (mol/mol)	x_1	0.75-2.09
Phthalic anhydride/CA (mol/mol)	x_2	1.61-2.94

Table 6. The correspondence between the coded x-scales and the original ones for the experiments carried out in acetone medium.

Coded scales of independent variables	Original scales of independent variables	
	x_1	x_2
-1.414	0.75	1.61
-1	0.95	1.80
0	1.42	2.27
+1	1.89	2.74
1.414	2.09	2.94

summarized in Tables 5-7, respectively.

The regression equation obtained in this case is:

$$Y = 0.626 + 0.23 x_1 - 0.003 x_2 + 0.031 x_1^2 + 0.016 x_2^2 + 0.037 x_1 x_2 \quad (4)$$

(29.714) (0.35) (3.773)
(1.969) (3.419)

$$S_1 = 0.00336, f_1 = 7; S_2 = 0.00252, f_2 = 4; S_3 = 0.00084, f_3 = 3; F = 0.4444; R^2 = 0.992$$

$$F_{p=0.01}(3, 4) = 16.69, \text{ therefore } F < F_{p=0.01}(3, 4) \text{ and}$$

Table 7. Experimental results and calculated values with equation (5) for the phthaloylation of CA in acetone medium.

Sample	x_1	x_2	Y_{exp}	Y_{calc}	ΔY	ϵ_r (%)
1	1	1	0.95	0.94	-0.02	1.7
2	1	-1	0.85	0.86	0.01	1.1
3	-1	-1	0.47	0.47	0.00	0.8
4	-1	1	0.42	0.40	-0.02	5.3
5	1.414	0	1.02	1.02	0.00	0.2
6	-1.414	0	0.36	0.37	0.01	2.7
7	0	1.414	0.65	0.64	-0.01	2.0
8	0	-1.414	0.67	0.64	-0.03	5.1
9	0	0	0.63	0.64	0.01	1.2
10	0	0	0.62	0.64	0.02	2.7
11	0	0	0.66	0.64	-0.02	3.5
12	0	0	0.59	0.64	0.05	7.4
13	0	0	0.63	0.64	0.01	1.2

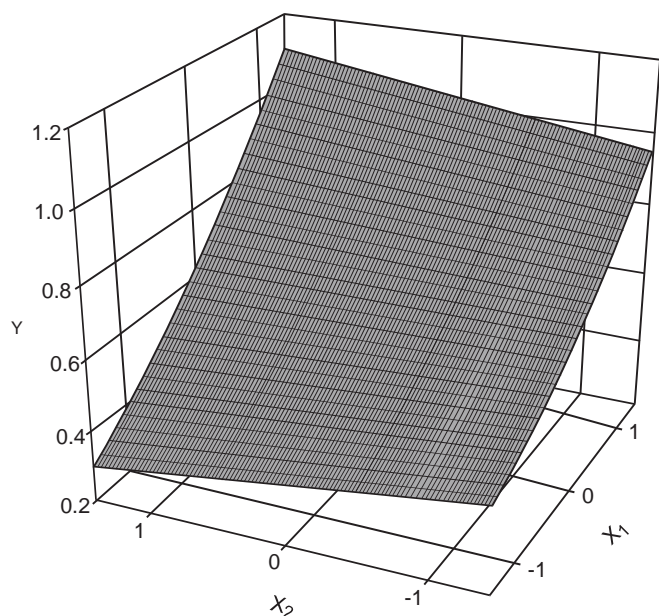

Figure 2. Dependence of DS_{ph} (Y) on molar ratios catalyst / CA (x_1) and phthalic anhydride/CA (x_2) for the phthaloylation of CA in acetone medium.

the estimated regression equation fits the data adequately.

The value of the square multiple correlation coefficient, R^2 , shows that 99.2 % of the sum of squares of deviations of Y from its mean is attributable to the regression.

The calculated values of Student t -tests, in parentheses under regression coefficients, show that in this case the terms in x_2 and x_2^2 are insignificant for a significance level of $p=0.05$ and they are removed from equation (4). Thus, the following simplified equation is obtained for the experiments performed in acetone:

$$Y = 0.637 + 0.230 x_1 + 0.037 x_1 x_2 + 0.029 x_1^2 \quad (5)$$

(26.877) (3.093) (3.208)

$$S_1 = 0.00529, f_1 = 9; S_2 = 0.00252, f_2 = 4; S_3 = 0.00277, f_3 = 5; F = 0.879365; R^2 = 0.988$$

$F_{p=0.01}(5,4) = 15.52$, therefore $F < F_{p=0.01}(5,4)$ and the estimated regression equation fits the data adequately.

The value of the square multiple correlation coefficient, R^2 , shows that 98.8 % of the sum of squares of deviations of Y from its mean is attributable to the regression.

Therefore, the obtained equation (5) describes ade-

quately the response surface in the experimental range for the experiments carried out in acetone medium. The values of Y calculated with equation (5) are presented in Table 7. The small values of relative errors, below 5 %, also show that the calculated Y values predict well the experimental ones.

The t -test values show that the coefficient of x_1 is significant for a significance level of $p = 0.01$, while the coefficients of the other terms are significant for a significance level of $p = 0.05$. That means that, in the experimental range, the catalyst is more important than the esterification agent in the case of CA phthaloylation in acetone medium.

Figure 2 illustrates this dependence for the phthaloylation of CA in acetone medium.

By comparing the two response surfaces (Figures 1 and 2), it can be seen that in acetic acid medium the variation of DS_{ph} is slower at high values of independent variables, while in acetone system this variation is more pronounced for high values of x_1 and x_2 .

CONCLUSION

The degree of phthaloylation of CAP obtained in acetic acid as well as in acetone media is dependent on both catalyst/CA and phthalic anhydride/CA molar ratios. The influences of these two parameters are dependent on the nature of the inert solvent employed. Thus, in acetic acid medium, DS_{ph} is mainly influenced by the amount of the phthaloylation agent (phthalic anhydride), while in the case of acetone used as reaction medium, the final DS_{ph} values are predominantly dependent on the molar ratio of catalyst/CA.

By using the obtained mathematical equations, the most suitable parameters of CAP synthesis in these two organic media can be chosen in order to prepare products with desired DS_{ph} values.

REFERENCES

1. Lee J.C., Cellulose acetate phthalate. In: *Handbook of Pharmaceutical Excipients*, Wade A., Weller P.J., (Eds.), American Pharmaceutical Association Pub., Washington D.C., 91-93 (1994).
2. Neurath A.R., Strick N., Li Y.Y., Debnath A.K., Cellulose

- acetate phthalate, a common pharmaceutical excipient, inactivates HIV-1 and blocks the coreceptor binding site on the virus envelope glycoprotein gp 120, *BMC Infect. Dis.*, **1**, 1-17 (2001).
3. Manson K.H., Wyand M.S., Miller C., Neurath A.R., Effect of a cellulose acetate phthalate topical cream on vaginal transmission of simian immunodeficiency virus in rhesus monkeys, *Antimicro. Agents. Chemo.*, **44**, 3199-3202 (2000).
 4. Neurath A.R., Strick N., Jiang S., Li Y.Y., Debnath A.K., Anti-HIV-1 activity of cellulose acetate phthalate: Synergy with soluble CD4 and induction of "dead-end" gp41 six-helix bundles, *BMC Infect. Dis.*, **2**, 6-12 (2002).
 5. Neurath A.R., Strick N., Li Y.Y., Water dispersible microbicidal cellulose acetate phthalate film, *BMC Infect. Dis.*, **3**, 27-33 (2003).
 6. Duncan R., The drawing era of polymer therapeutics, *Nat. Rev. Drug. Discov.*, **2**, 347-360 (2003).
 7. Fakhouri F.M., Tanada-Palmu P.S., Grosso C.R.F., Characterization of composite biofilms of wheat gluten and cellulose acetate phthalate, *Braz. J. Chem. Eng.*, **21**, 261-264 (2004).
 8. Malm C.J., Mench J.W., Fulkerston B., Hiatt G.D., Preparation of phthalic acid esters of cellulose, *Ind. Eng. Chem.*, **49**, 84-88 (1957).
 9. Wagenknecht W., Paul D., Philipp B., Ludwig T., Zur phthaloylierung von celluloseacetaten, *Act. Polym.*, **38**, 551-554 (1987).
 10. Kryajev V.N., Pogosov Yu.L., Ftalilirovanie atzetiltzeliulozi v Uksusnokisloi Srede, *Plast. Massy.*, **10**, 18-20 (1969).
 11. Tanghe L.J., Genung L.B., Mench W., Hydrolysis of cellulose acetate. In: *Methods in Carbohydrate Chemistry*, Whistler R.L. (Ed.), Vol. III, Academic Press, New York - London, 198-201 (1963).
 12. Tanghe L.J., Genung L.B., Mench W., Determination of acetyl content and degree of substitution of cellulose acetate., In: *Methods in Carbohydrate Chemistry*, Whistler, R.L. (Ed.), Vol. III, Academic Press, New York-London, 201-203 (1963).
 13. Malm C.J., Genung L.B., Kuchmy W., Analysis of phthalic acid esters of cellulose and of polyvinyl alcohol, *Anal. Chem.*, **25**, 245-249 (1953).
 14. Box G.E.P., and Hunter J.S., Multifactor experimental designs, *Ann. Math. Stat.*, **28**, 195-(1957).
 15. Cochran W.G., Cox G.M., *Experimental Designs*, 2nd (ed), John Wiley, New York-London-Sydney, Ch. 8A (1968).
 16. Mihail R., Introducere in strategia experimentarii cu aplicatii din tehnologia chimica, (Ed), *Stiintifica si enciclopedica*, Bucuresti, Ch.6 (1976).
 17. Kafarov V., *Cybernetic Methods in Chemistry & Chemical Engineering*, Mir, Moscow, Ch. II (1974).