

“Research Note”

2-D AND 3-D ANALYSES OF UNDERGROUND OPENINGS IN AN INHOMOGENEOUS ROCK MASS*

M. AHMADI,** K. GOSHTASBI AND R. ASHJARI

Dept. of Mining Engineering, Tarbiat Modares University, I. R. of Iran

Email: moahmadi@modares.ac.ir

Abstract– Underground excavations are of immense interest to mining engineers worldwide. Underground projects are often complex in nature where geological features, geomechanical parameters of rock mass and stress play important role. The present research has conducted 2D, Quasi-3D and 3D continuum analyses of the underground excavation of the extension phase at the Masjed-e-Solaiman hydroelectric project in Iran’s southwestern province of Khuzestan. The effects of weak zones and the formation of multiple openings in the inhomogeneous rock mass have, in particular, been taken into account during those analyses. This study reveals that 2D is more deformed than the other models, whereas 3D analysis yields the best results comparable with in-situ measurements.

Keywords– Numerical modeling, 2-D and 3-D analyses, Powerhouse cavern, underground excavations, deformation

1. INTRODUCTION

Underground excavations usually possess different shapes, varying from straight tunnels to complex excavations in hydroelectric projects. Excavations in rock mass cause a new distribution of stresses, and as such, the amount of deformations and stress distribution around the underground opening are significant to analyze stability as well as to design a proper support system [1].

Although empirical knowledge and engineering judgment play an important role in practical rock mechanics, numerical analyses have also become crucial with the advancement of computer skills.

Numerical analyses are divided into 2-D and 3-D analyses. 2-D analysis is applied once two-dimensional assumption is acceptable. But, since the two-dimensional method is inadequate in complex geometries and geology, 3-D numerical analysis becomes necessary.

Here, plain strain assumption seems to be invalid due to the discontinuous nature of rock mass and the presence of joints, beddings, faults and induced stresses. On the other hand, this assumption is invalid due to the cyclic nature of excavation and support installation, at least in the vicinity of the working face.

Eberhardt *et al.* and Meyer *et al.* [2, 3] demonstrated that three-dimensional numerical analysis allows a more detailed examination of stress concentrations around the ends and edges of an excavation. In the case of an advancing tunnel face, three-dimensional stress effects play an important role, especially with respect to induced stress concentrations and rock strength degradation.

Duddeck [4] noted that, if the engineering design requires knowledge of induced stresses and deformations of the tunnel structure, the geometrical changes at the working face as well as the sequences of excavation and support must be taken into consideration.

*Received by the editors February 5, 2006; final revised form July 14, 2007.

**Corresponding author

Studies conducted by Pan and Hudson [5] and Kielbassa and Duddeck [6] have also indicated that two-dimensional plain strain models are inadequate when stresses and tunnel convergence near the tunnel face are modeled.

When a tunnel continues to go ahead into a more complex geological environment, knowledge of three-dimensional induced stress becomes even more necessary, given the adverse consequences such stress paths will have on the host rock strength. Further, corresponding displacements, the extent of the damage, and the plastic zones at the front of the tunnel face, as well as the stability of subsequent excavations are important [1].

Dahawan *et al.* [7] studied 2-D and 3-D elasto-plastic analyses for a set of four underground openings. Their study revealed that deformations obtained from 3-D elasto-plastic analysis in weak and inhomogeneous rock mass are greater than those from 2-D analysis.

Following a similar procedure, the aptness of 2-D and 3-D elasto-plastic analyses has also been considered in the present study.

2. PROBLEM AND FIELD INVESTIGATIONS

The Masjed-e-Soleiman dam and hydroelectric power plant are constructed on the Karun River, close to the Godar-Landar village in the Khuzestan province of Iran. A hydroelectric power plant with a 2000 MW capacity (100 MW in each phase) was constructed in two phases. In the extension phase, two main underground excavations being carried out are: (a) powerhouse cavern (30m×50m×112m) and (b) transformer cavern (13.6m×21m×110m) (Fig. 1).

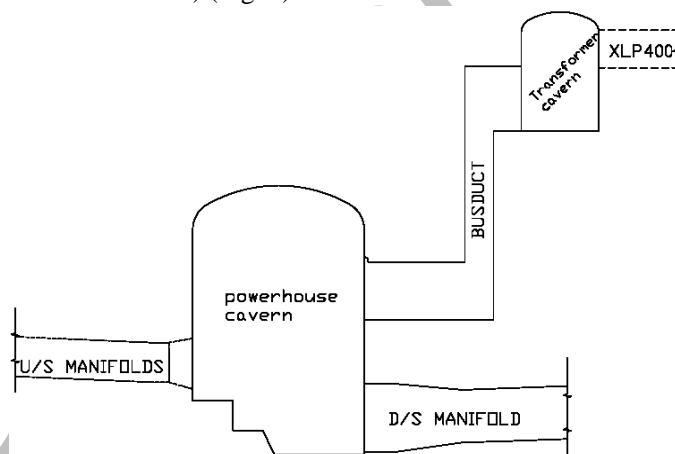

Fig. 1. Details of the openings at Masjed-e-Soleiman hydroelectric project

These openings are located in the Aghajari and Bakhtiari formations that consist of siltstone, claystone, sandstone and conglomerate. The average overburden thickness of the openings is about 320m. Flat jack and overcoring tests detected that the vertical stress is equal to overburden weight and the in-situ stress ratio (k) is 0.5 [8]. The geomechanical parameters of rock mass are shown in Table 1.

Table 1. The rock mass properties used in the present study [10]

Rock group	σ_t (Mpa)	Dilation (°)*	C (Mpa)	Φ (°)	ν	E_m (GPa)
Conglomerate	2	11	2.87	43	0.2	15
Sandstone	2	8	1.67	38	0.2	7
Siltstone of roof	1	5	0.73	25	0.25	6
Siltstone of wall	1	5	0.73	30	0.25	6
Claystone	1.5	4	0.5	24	0.25	6

*Dilation angles are changed according to engineering judgment

The support system in the caverns consists of 15cm to 20cm shotcrete, wire mesh, 6m and 10m long wedge anchored bolts, 3m to 10m grouted rock bolts, and 15m to 25m double protected tendons. During excavation, minor roof instabilities appeared in claystone and siltstone that were later reinforced with additional support [9].

The monitoring system installed in the caverns consists of 71 extensometers and 168 load cells. Since extensometers were installed about 3 months after the excavation, it led to the loss of important information about displacements, and hence comparison between the acquired results of modeling and extensometers is not possible.

3. NUMERICAL ANALYSES

In order to analyze underground openings, FLAC2D, FLAC3D and 3DEC codes developed by the Itasca consulting group have been utilized in the current research [11-13]. Firstly, a 2-D model was prepared in the chainage, 71.25m of the powerhouse cavern by using FLAC2D. Then a Quasi-3D model was constructed through the FLAC3D code. Finally, with the help of FLAC3D and 3DEC codes, 3-D models geared up (Fig. 2).

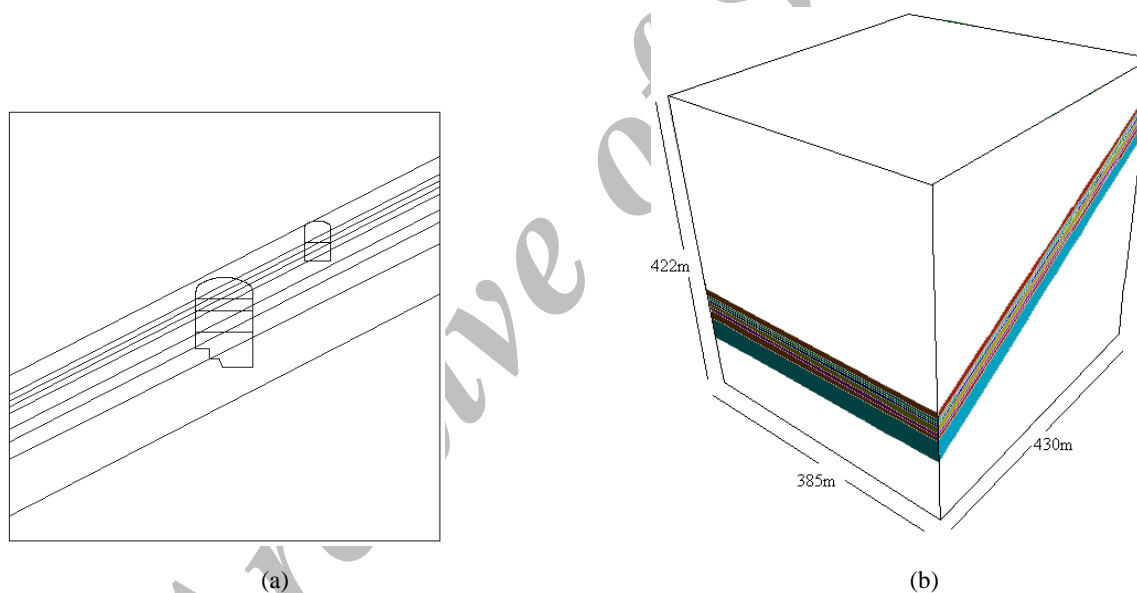

Fig. 2. Discretization of the models, a) 2D and Quasi-3D analyses, b) 3D analyses

The dip of each layer in the longitudinal direction of the caverns is about 1-1.5%. However, the dip of layers in the longitudinal direction has been ignored in the 3-D analysis, carried out with the FLAC3D code because of the modeling limitations in this code. But that was not the case of the 3DEC model where real dips are considered.

The location of each group of rock mass is presented in Fig. 3. It is assumed that the rock mass obeys the Mohr-Columb yield criterion.

To authenticate excavation sequences, elements in the models were deleted at different stages, as shown in Fig. 4. 3-D models have been excavated by 11m advancements. The powerhouse and transformer caverns have one and two working faces, respectively. The excavation of the transformer cavern started from the middle of the cavern and extended on both sides, same as was done practically.

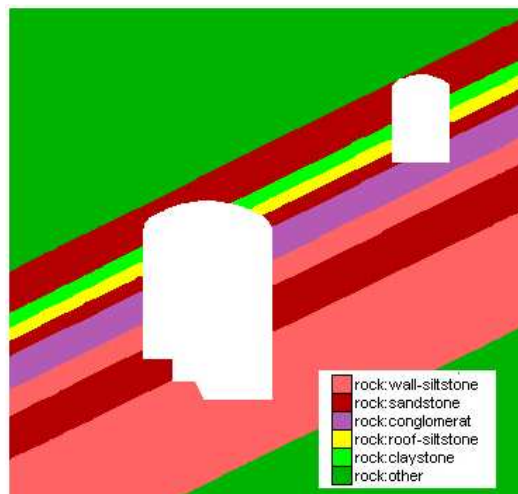

Fig. 3. Location of each group of rock masses

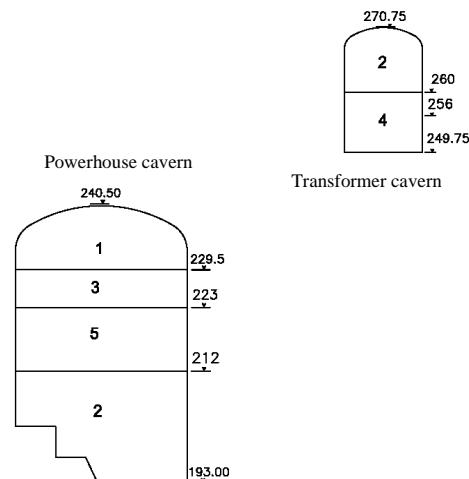

Fig. 4. Excavation sequence for the powerhouse and transformer caverns

4. COMPARATIVE RESULTS OF ANALYSES

In order to compare the results, deformations from different locations of the caverns were used. Figures 5-7 show the results of deformations at 3 points in the roof of the powerhouse cavern against the excavation steps.

It can be observed from the plots that 3-D and Quasi-3D analyses are in conformity, whereas the 2-D analysis results are far away from the others. Deformation trends are similar, but 3-D analysis reveals additional information about this trend.

Table 2 presents the computed deformations and results of extensometers. By comparing 3-D analyses, it can be found that deformations of finite difference analysis (FLAC3D) are a little more than those of distinct element analysis (3DEC). This difference is seen more in weak rocks and as such, with the increasing strength of rock, the difference decreases. When the results of Quasi-3D and 3-D analyses of FLAC3D are being compared, it is concluded that deformations obtained from 3-D analysis are more in the weak rock mass as compared to Quasi-3D analysis, whereas for strong rock mass it is vice versa.

Due to delayed installation of extensometers, it was unsuitable to compare those computed and monitored deformations. For that matter, tensions in bolts have been selected for comparison (Table 3). According to the loads, it is clear that 3-D analysis, which has been carried out by using FLAC3D code, shows the best agreement with field measurements. In this table, the results of a 3DEC code have not been presented because of the limitations of the code.

Table 2. Computed and monitored deformations (mm) of powerhouse

	Roof			U/S wall			D/S wall		
	U/S	D/S	Center	El. 207	El. 217	El. 225	El. 207	El. 217	El. 225
Monitored	15.3	28.85	19.5	15.78	19.94	25.05	29.15	16.58	19.8
FLAC2D	21.37	36.9	27.82	35.15	28.79	54.1	51.61	32.23	29.36
Quasi-3D	19.51	24.62	24.54	36.78	27.78	42.82	48.05	27.88	23.59
FLAC3D	18.85	26.01	23.53	43.55	29.42	39.51	43.65	25.08	22.46
3DEC	18.26	24.84	23.15	39.46	28.76	38.85	42.18	24.3	21.82

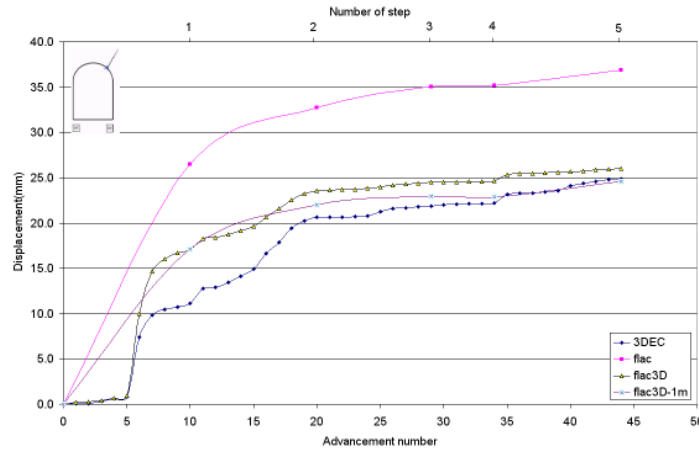

Fig. 5. Deformations in the D/S of roof in powerhouse for different steps

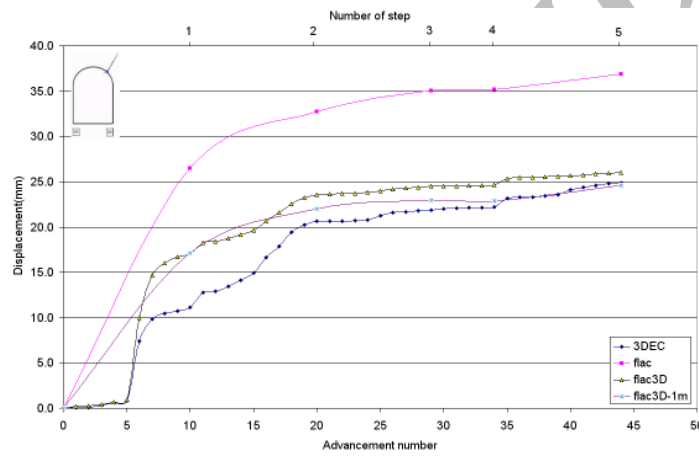

Fig. 6. Deformations in the center of roof in powerhouse for different steps

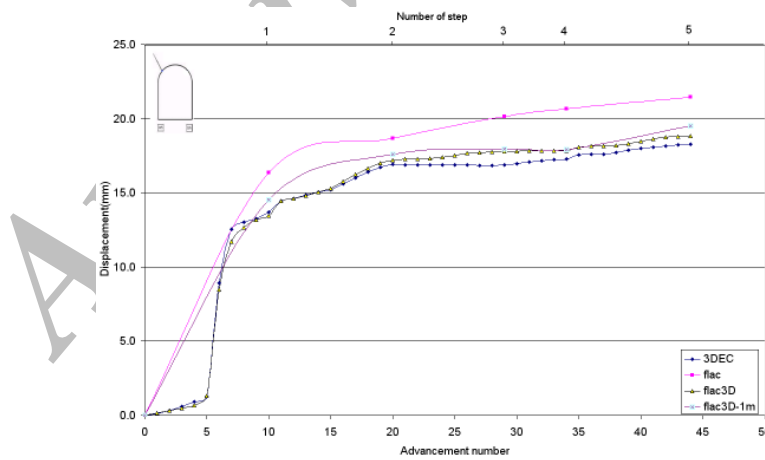

Fig. 7. Deformations in the U/S of roof in powerhouse for different steps

Table 3. Computed and monitored loads in bolts in the roof of powerhouse (KN)

	Center	U/S	D/S
Loadcell	120	69.95	143.7
Flac2D	130.5	62.23	148.7
Quasi-3D	105.26	63.42	129.83
FLAC3D	116.2	69.58	137.74

5. CONCLUSION

Based on the results and above discussions the following conclusions can be drawn:

1. Compared to the 2-D analysis, the effect of the non-homogeneity of rock mass has been better revealed in 3-D analysis, as the effect of weak zones is suitably taken into account in the 3-D analysis.
2. For inhomogeneous rock mass with weak zones, 3-D elasto-plastic analysis exhibits the best agreement with the field observations; however 2-D elasto-plastic analysis yields conservative results.
3. In the weak rock mass, deformations determined from 3-D analysis are more than those of Quasi-3D analysis, whereas for strong rock mass, deformations are less for 3-D analysis compared to Quasi-3D analysis.
4. In 3-D analyses, deformations of finite difference analysis (FLAC3D) are a bit more than the deformations of distinct element analysis (3DEC). In weak rocks this difference is more significant and with the increasing rock strength, the difference decreases.

REFERENCES

1. Eberhardt, E. (2001). Numerical modeling of three-dimension stress rotation ahead of an advancing tunnel face. *International J. Rock Mech. & Min. Sci.*, Vol. 38, pp. 499-518.
2. Eberhardt, E., Stead, D., Reeves, M. J. & Connors, C. (1997). Design of tabular excavations in foliated rock: an integrated numerical modeling approach. *Geotech Geol Eng.*, Vol. 15, No. 1, pp. 47-85.
3. Meyer, L. H. I., Stead, D. & Coggan, J. S. (1999). Three dimensional modeling of the effects of high horizontal stress on underground excavation stability. In: Vouille G, Berest P, Editors. *Proceedings of the Ninth International Congress on Rock Mechanics*, Paris. Rotterdam: A.A. Balkema, pp. 411-16.
4. Duddeck, H. (1991). Application of numerical analysis for tunneling. *Int. J. Numer. Anal. Methods Geomech.* Vol. 15, pp. 223-39.
5. Pan, X. D. & Hudson, J. A. (1988). Plane strain analysis in modeling three-dimensional tunnel excavations. *Int. J. Rock Mech. Min. Sci. Geomech. Abstr.*, Vol. 25, pp. 331-37.
6. Kielbassa, S., Duddeck, H. (1991). Stress-strain fields at the tunneling face-three-dimensional analysis for two-dimensional technical approach. *Rock Mech. And Rock Eng.*, Vol. 24, pp. 115-132.
7. Dahawan, K. R., Singh, D. N. & Gupta, I. D. (2002). 2D and 3D finite element analysis of underground openings in an inhomogeneous rock mass. *International J. Rock Mech. & Min. Sci.* Vol. 39, pp. 217-227.
8. Iran Water & Power Dev. Co. (1994). Geology & site investigation report. Godar-E-Landar, H. E. P. P.
9. Moshanir & Lahmeyer Int. & Nippon Koei, Godar-e-Landar, H. E. P. P., Rock, (1994). Support for powerhouse and transformer caverns., p. 55.
10. Stabel, B., Bauckhage, B. & Masjid-E-Soleiman H. E. P. P. (2000). Powerhouse Cavern, Back Analysis Report, Nov.
11. Itasca Consulting Group, Inc., 3DEC, 3 Dimensional Distinct Element Code, Version 2.00, User's Manual.
12. Itasca Consulting Group, Inc., FLAC, Fast Lagrangian Analysis of Continua, Version 4.00, User's Manual.
13. Itasca Consulting Group, Inc., FLAC3D, Fast Lagrangian Analysis of Continua, Version 2.1, User's Manual.