

NONLINEAR FINITE ELEMENT ANALYSIS OF COMPOSITE RC SHEAR WALLS*

A. KHEYRODDIN** AND H. NADERPOUR

Dept. of Civil Engineering, Semnan University, Semnan, I. R. of Iran,
Email: akheirodin@semnan.ac.ir

Abstract– Composite Reinforced Concrete (RC) wall system refers to a cantilever composite wall, where steel or Fiber Reinforced Polymer (FRP) components are embedded in or attached to an RC wall. The results of an analytical and parametric study on the effectiveness of using externally bonded steel plates and FRP sheets on RC shear walls as a retrofit technique so as to improve their seismic behavior have been investigated in this paper. Calibration and verification of a base RC wall has been done by comparing the results of the finite element model and also the experimental model. Analytical results are used to evaluate the capacity curves (Load-Displacement relationships) of strengthened RC shear walls. Analysis results of a model with an optimized thickness of a steel jacket instead of an over-hanging part of the boundary element show the ductile behavior of a strengthened wall close to the behavior of the base RC wall with boundary elements; this achievement would lead to the theory that steel jacketing could be an alternative for the boundary elements of RC shear walls. The application of externally bonded Carbon Fiber Reinforced Polymer (CFRP) sheets is an effective seismic strengthening procedure in order to improve the behavior of reinforced concrete shear walls. In the retrofit method, using CFRP sheets, the flexural and shear strength would be increased by applying the CFRP sheets with the fibers oriented in the vertical or horizontal direction. The carbon fiber sheets are used to increase the precracked stiffness, the cracking load (up to 35%) and the ultimate flexural capacity (up to 18%) of the RC walls. Finally, a wrapped CFRP sheet around the plastic hinge area of the RC wall in parallel with boundary elements, provides not only enough shear strength, resulting in a ductile flexure failure mode, but also the confinement of concrete in the plastic hinge leads to an increase in the ductility of the RC wall.

Keywords– Composite, finite element, FRP, RC, shear wall, steel plate

1. INTRODUCTION

Due to their high initial stiffness and lateral load capacity, shear walls are an ideal choice for a lateral load-resisting system in an RC structure. The stiffness of an RC component depends on material properties (including current condition), component dimensions, reinforcement quantities, boundary conditions, and stress levels. Each of these aspects should be considered and verified when defining effective stiffnesses; Shear walls are major members in RC buildings for resisting lateral loads. Not only must they provide adequate strength, but also sufficient ductility to avoid brittle failure under strong lateral loads, especially during an earthquake. For the design of a ductile structural wall it is desirable that yielding of flexural reinforcement in the plastic hinge region, normally at the base of the wall, would control the strength, inelastic deformation and energy dissipation. In other words, to enhance ductility, the concrete in the compression zone of the shear wall should not fail prior to the yielding of the flexural reinforcement [1, 2].

*Received by the editors June 26, 2006; final revised form November 17, 2007.

**Corresponding author

The term ‘‘composite wall system’’ refers to a number of possible configurations including: (1) cantilever composite walls, where steel or FRP components are embedded in or attached to RC walls, (2) Hybrid coupled walls, where steel beams are used to couple two or more RC or composite walls in a series, and (3) Hybrid dual systems, where RC walls are placed in parallel with steel moment frames [3].

Although it is generally accepted that the concrete confinement rendered by the provision of externally bonded FRP sheets would increase the strength and ductility of a shear wall, none of the analysis methods given in the design codes allows for such effect. This may be due to the complicated failure mechanism of shear walls and the over-simplified modeling of the properties of RC in the codes. Nevertheless, by use of the finite element method, it should be possible to analyze the effect of concrete confinement on the behavior of shear walls. In this paper, investigating the behavior of RC shear walls after being composited using externally bonded steel plates and FRP sheets and then comparing their analysis results with the results of RC shear walls (with no composite component) in order to indicate the effectiveness of using composite elements has been attempted.

2. ANALYSIS MODELS FOR COMPOSITE SHEAR WALL SYSTEMS

Four kinds of analysis models are usually used to model composite wall systems: (1) equivalent frame models, (2) multi-spring models, (3) fiber section models, and (4) continuum finite element models. Compared to the other three models, continuum elements offer several distinct advantages. While continuum element models require larger amounts of input data than equivalent models, the input parameters are easier to specify. They can be easily used to model three-dimensional situations. Continuum models provide a more physical description of the nonlinearities that occur in RC shear walls. The possibility of modeling the distribution of diagonal cracking and local crushing makes such models more realistic. Continuum models are able to describe local behavior at reentrant corners and at other discontinuities more accurately. For example, bearings between steel and concrete components can be simulated using contact elements. Continuum finite element models can account for local reinforcing details such as diagonal reinforcement, edge reinforcement, etc., and can model concrete crushing, cracking, and steel yielding. They also capture important behavioral responses such as axial-flexure interaction, inelastic shear deformation, and the steel confining effect on concrete behavior, concrete compression softening, and concrete tension stiffening [3]. By considering the above explanations, in this research program, the continuum finite element method has been used.

3. NONLINEAR FINITE ELEMENT ANALYSIS OF REINFORCED CONCRETE

a) General

Nonlinear response of RC is caused by cracking, plastic deformations in compression and crushing of the concrete and plastic deformations of the reinforcement. Other, usually less important, time-independent nonlinearity arises from a bond slip between steel and concrete, aggregate interlock of cracked concrete and dowel action. Time-dependent effects, such as creep, shrinkage and temperature change also affect nonlinear response, but can be ignored for short-duration earthquake loads. Cracking is the most important factor on material nonlinearity of concrete. In the following, only nonlinear properties due to cracking, plastic deformations of concrete and steel, and aggregate interlock are considered.

b) Finite element model

The solid element SOLID65 in the ANSYS program was used in the analysis [4]. It can be used for the three-dimensional modeling of solids with or without reinforcing bars. Eight nodes define the element, each having three translation degrees of freedom. Reinforcement can be defined in three different directions. The solid part of the element, e.g., the concrete, is capable of describing cracking, plastic deformations and crushing. The plasticity model for concrete is based on the flow theory of plasticity, Von Mises' yield criterion, isotropic hardening and associated flow rule. The geometry and node locations for this element type are shown in Fig. 1. Cracking is permitted in three orthogonal directions at each integration point. The cracking is modeled through an adjustment of the material properties (i.e., by changing the element stiffness matrixes) that effectively treat the cracking as "smeared" cracks. The concrete material is assumed to be initially isotropic. If the concrete at an integration point fails in uniaxial, biaxial, or triaxial compression, the concrete is assumed crushed at that point. Crushing is defined as the complete deterioration of the structural integrity of the concrete (e.g., concrete spalling). The reinforcement is assumed smeared throughout the elements.

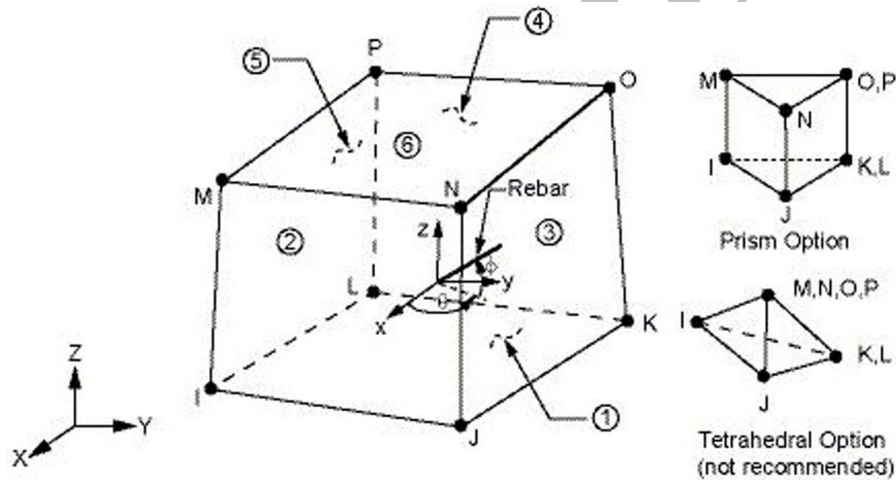

Fig. 1. Solid65–3-D reinforced concrete solid [4]

The shear transfer coefficient, β_t , represents conditions of the crack face. The value of β_t ranges from 0.0 to 1.0, with 0.0 representing a smooth crack (complete loss of shear transfer) and 1.0 representing a rough crack (no loss of shear transfer) [4]. The value of β_t , used in many studies of RC structures, however, varied between 0.05 and 0.25[5-8]. A number of preliminary analyses were attempted in this study with various values for the shear transfer coefficient within this range, but convergence problems were encountered at low loads with β_t less than 0.2. Therefore, the shear transfer coefficient used in this study was equal to 0.2. The shear transfer coefficient for a closed crack β_c was taken as 1.0.

c) Verification of analytical model

The experimental data for the RC walls were obtained from Barda [9]. Laboratory tests of eight scaled, low-rise shear walls with boundary elements have been described. All the shear-walls have the same geometry, but the reinforcement varies between the tests. The boundary elements were supposed to simulate the effect of cross walls and an overlying floor slab. The horizontal length of the test walls was 1900 mm; the height was 610 mm, and the thickness was 100 mm. Only one test was analyzed with the ANSYS program. In Fig. 2 the tilt-up from the laboratory tests is shown.

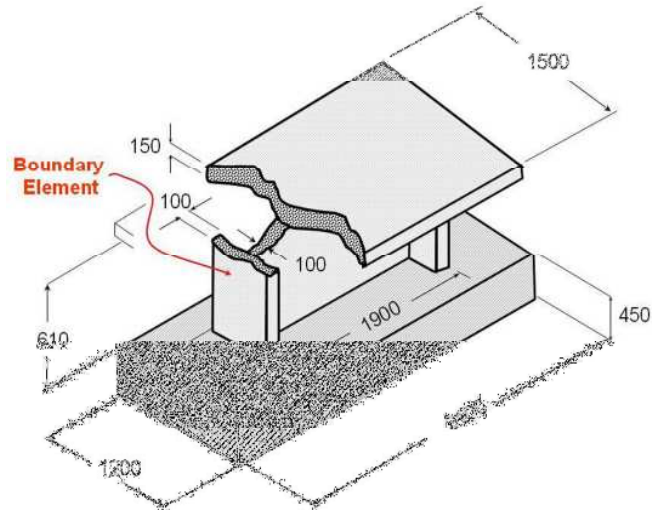

Fig. 2. Tilt-up of laboratory tested shear wall with boundary elements (dimensions in mm)

In Fig. 3 the finite element model of the test is shown; the number of elements in this model was equal to 1146. In Fig. 4 the measured and computed load-displacement curves are shown for the shear walls. As can be seen, the finite element analysis can simulate the test results fairly well. The main conclusion from the verification against experimental data is that the finite element program can be used to simulate the whole load-deformation curve, i.e., the elastic part, the initiation of cracking, shear cracks and crushing fairly well. However, the determination of the ultimate load is difficult as it is affected by the hardening rule, convergence criteria and iteration method used.

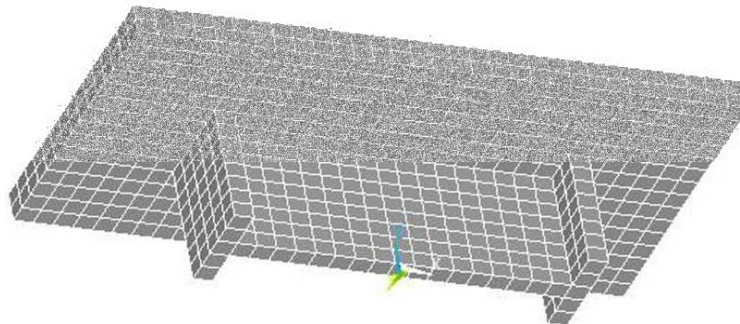

Fig. 3. Finite Element model of the laboratory test

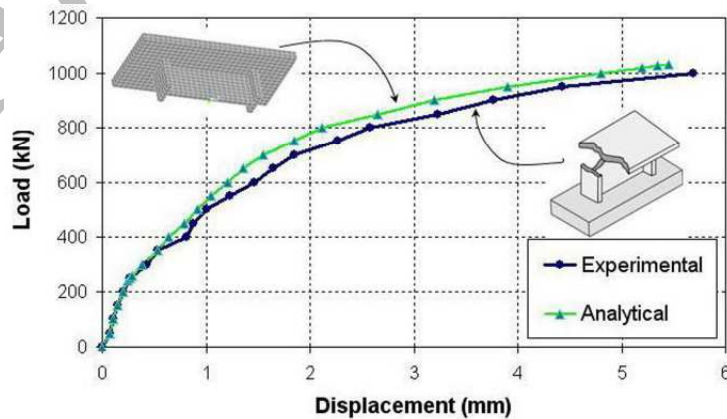

Fig. 4. Comparison of experimental and FE analysis load-displacement curves for RC shear wall with boundary elements

4. EXTERNALLY BONDED STEEL PLATES

a) General

Research on the behavior of RC members with externally bonded steel plates has mainly focused on columns or piers where its use is more common [10-14]. The application of steel plates on RC walls has attracted much less attention by researchers. Parametric studies on the effectiveness of using externally bonded steel plates as a retrofit technique generally concentrate on changing the size and location of the plates. Elnashai and Pinho suggest a more economical approach by classifying the retrofit processes by their impact on structural response characteristics [15]. The experimental program was conducted by Elnashai and Salama at Imperial College [16]. They tested this theory by individually increasing the three design response parameters: stiffness, strength and ductility. Concrete walls were used for the experimental program, and the experimental data were compared with the computer analysis results. For the stiffness-only scenario, external bonded steel plates were used for the increase in stiffness without any change in strength and ductility. External steel plates on the smaller face of the wall could be used to increase only strength. Finally, for the ductility-only scenario, U-shaped external confinement steel plates were used.

Although the influence of these intervention techniques on the global behavior of RC walls is undeniable, it is architecturally unappealing since it changes the exterior and/or interior layout of the structure, resulting in a significant reduction of the building's usable space. In the following, the impression of using externally bonded steel plates as an alternative to the boundary elements of RC walls is presented.

b) Finite element model

Three retrofitted RC walls were analyzed using externally bonded steel plates, but only after eliminating the over-hanging part of the boundary elements; In this case, the steel plates were able to form steel jackets (Channel-shaped) for the end parts of the RC walls. In order to achieve the best steel jacket to be consistent in behavior with the control wall, steel plates with different thicknesses were analyzed. Geometry and meshing of the finite element model of strengthened RC walls by steel jackets is available in Fig. 5. The number of elements in this model was equal to 1162.

An eight-node solid element, Solid45, was used for the externally bonded steel plates in the models. This element is similar to the Solid65 element, but it does not include special cracking and crushing capabilities.

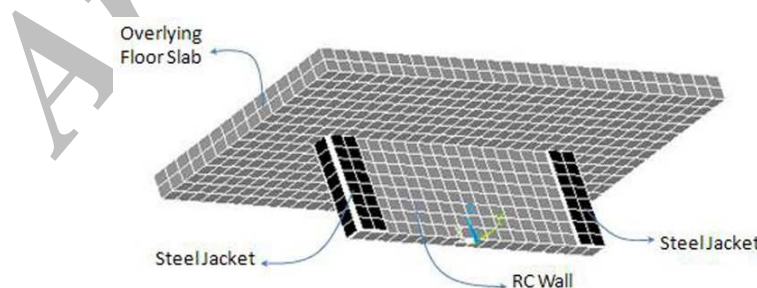

Fig. 5. Finite element model of RC wall strengthened by steel jackets

c) Analysis results

The analysis results of the RC walls retrofitted by different steel jackets are available in Figure 6. The results showed that the thickness of the jackets plays a vital role in the behavior of the walls. Capacity curves showed that by using the 4mm steel jacket as a substitute for the overhanging part of boundary

elements, the ultimate strength of the wall, relative to the control wall, decreased by 35 percent; In contrast, 10 mm steel jackets increased the ultimate strength by 12 percent. This lateral load capacity corresponds to a displacement of 2.85 mm, revealing great stiffness of the retrofitted wall. The RC wall, retrofitted by a 6 mm steel jacket, presented better results in comparison with other walls. The curve shows that such RC walls can be effectively retrofitted with these thin 6mm rectangular plates. Although the maximum lateral load capacity was somehow greater than the control wall, its capacity curve shows a ductile behavior of the model that is much closer to the behavior of the control wall. This important result leads to the theory that steel jacketing could be an alternative for the boundary elements of RC shear walls.

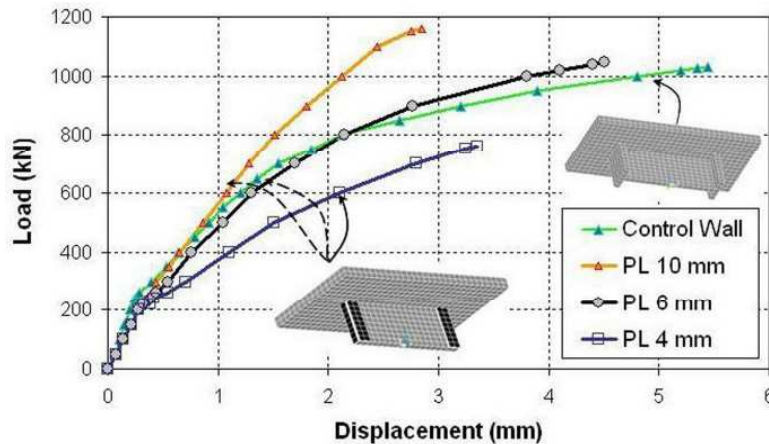

Fig. 6. Comparison of load-displacement curves for RC shear walls strengthened by steel jackets.

5. FIBER REINFORCEMENT POLYMER SHEETS

a) General

Several techniques are currently available to retrofit and strengthen buildings with insufficient stiffness, strength and/or ductility. These techniques include the strengthening of existing shear walls by the application of shotcrete or ferrocement, filling in openings with RC and masonry in fills, and the addition of new shear walls and steel bracing elements [17]. While these techniques are effective in improving the earthquake resistance of a building, they may add significant weight to the structure and thus alter the magnitude and distribution of the seismic loads. Also, the existing techniques are generally very labor intensive.

Fiber reinforced polymer (FRP) materials are composite materials consisting of high strength fibers immersed in a polymer matrix. The fibers in an FRP composite are the main load-carrying elements and exhibit very high strength and stiffness when pulled in tension. An FRP laminate will typically consist of several million of these thin, thread-like fibers. The polymer matrix protects the fibers from damage, ensures that the fibers remain aligned, and allows loads to be distributed among many of the individual fibers in the composite.

In the retrofit method using CFRP sheets, the flexural strength of a shear wall is increased by applying the CFRP sheets with the fibers oriented in the vertical direction. Essentially, the added CFRP sheets contribute to the flexural strength of the wall in similar mechanisms as the vertical steel reinforcements. For enhancement to the shear strength of a shear wall, the CFRP sheets are bonded externally to the wall with the fibers oriented in the horizontal direction [18-21].

b) Finite element model

The first wall (SW1) was strengthened with one vertical ply of carbon fiber sheets; The second wall (SW2) was strengthened with two vertical plies of carbon fibers and the third wall (SW3) was strengthened with two vertical plies of carbon fibers, one in the horizontal direction. The geometry and meshing of the models is available in Fig. 7. The number of elements in this model is equal to 1354.

A layered solid element, Solid46, was used to model the FRP composites. The geometry and node locations for this element type and the schematic of FRP composites are shown in Fig. 8. This element allows for up to 100 different material layers with different orientations and orthotropic material properties in each layer. It has three degrees of freedom at each node and translations in the nodal x, y, and z directions. To simulate the perfect bonding of the CFRP sheets with concrete, the nodes of Solid46 elements were connected to the nodes of Solid65 elements at the interface so that the two materials shared the same nodes. The material properties for FRP composites are available in Table 1. It should be noted that modeling the contact of concrete and composite needs further specified research.

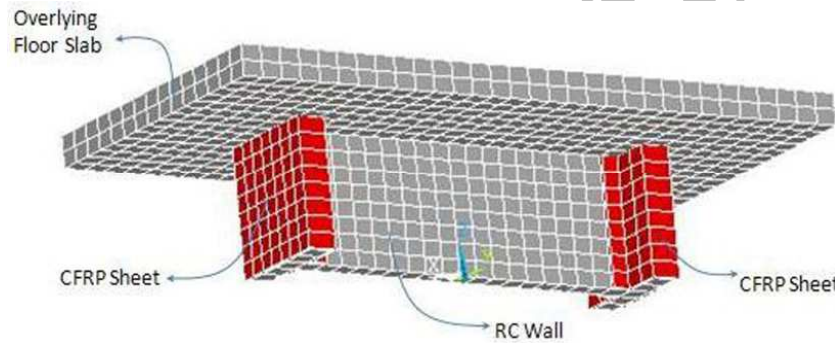

Fig. 7. Finite element model of strengthened walls by externally bonded CFRP sheets

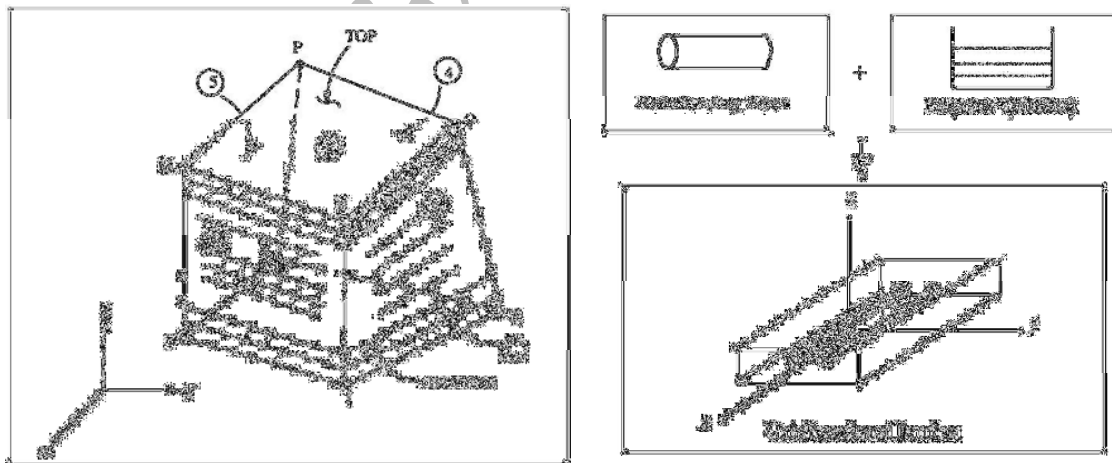

Fig. 8. (a) Solid46–3-D layered structural solid

(b) Schematic of FRP composites [4]

Table 1. Summary of material properties for FRP composites

FRP Composite	Elastic modulus (GPa)	Major poisson's ratio	Tensile strength (MPa)	Shear modulus (MPa)	Thickness of laminate (mm)
CFRP	$E_x = 230$	$\nu_{xy} = 0.22$	3500	$G_{xy} = 13100$	2.0
	$E_y = 20$	$\nu_{xz} = 0.22$		$G_{xz} = 13100$	
	$E_z = 20$	$\nu_{yz} = 0.30$		$G_{yz} = 7700$	

c) Results of finite element analysis of strengthened RC walls

I-Analysis Results of SW1: The first strengthened wall was upgraded by the application of one vertical layer of carbon sheeting on each side of the wall. The load versus top horizontal displacement curve of this wall specimen is presented in Fig. 9. As can be seen from the curves, the initiation of cracking of concrete was on the load of 320 kN. This represented a 23 percent increase in the cracking strength of the control wall. The lateral load capacity was determined to be 1150 kN at the ultimate displacement of 5.1 mm. Compared to the control wall, the application of the fiber reinforced polymer sheets resulted in a 12 percent increase in its ultimate failure.

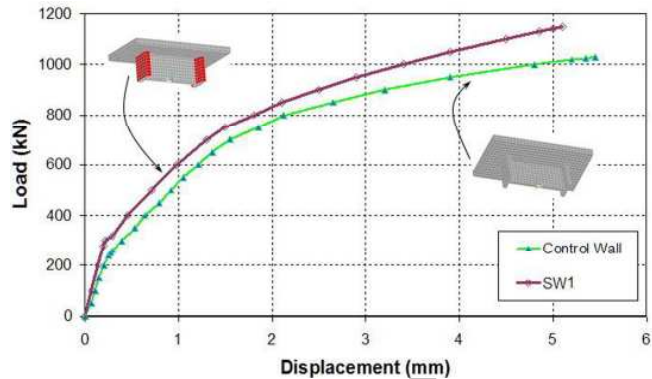

Fig. 9. Comparison of FE analysis load-displacement curves for the “Control wall” and “Strengthened wall with one vertical CFRP layer”

II-Analysis Results of SW2: The application of two vertical layers of CFRP sheets instead of one on each side of the wall further enhanced the flexural capacity of the wall. The load versus top horizontal displacement curve for this specimen is shown in Fig. 10. The application of double the amount of CFRP sheets, as compared to the previous strengthened wall specimen, did not significantly increase the crack load of the wall; because the amount of the CFRP reinforcement material was relatively small compared to the total area of concrete and steel reinforcement.

Before the cracking of concrete, the contribution of the CFRP sheets in the flexural resistance of the wall was relatively small. The flexural resistance from CFRP sheets greatly increased after crushing the concrete. The initiation of cracking the concrete was on the load of 330 kN. This represented a 27 percent increase in the cracking strength of the control wall. The lateral load capacity was determined to be 1165 kN at the ultimate displacement of 4.9 mm. Compared to the control wall, the application of the fiber reinforced polymer sheets resulted in a 14 percent increase in its ultimate failure.

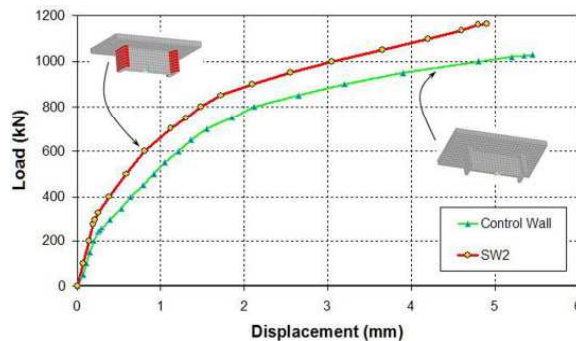

Fig. 10. Comparison of FE analysis load-displacement curves for the “Control wall” and “Strengthened wall with two vertical CFRP layers”

III-Analysis Results of SW3: Strengthened Wall No. 3 (SW3) had two vertical layers of CFRP sheets and one horizontal layer on each side of the wall. The load versus top horizontal displacement curve is presented in Fig. 11. The initiation of cracking the concrete was on the load of 350 kN. This represented a 35% increase in the cracking strength of the control wall. The lateral load capacity was determined to be 1185 kN at the ultimate displacement of 4.75 mm. Compared to the control wall, the application of the fiber reinforced polymer sheets resulted in an 18 percent increase in its ultimate failure. Finally, the concrete at the base of the wall was completely crushed.

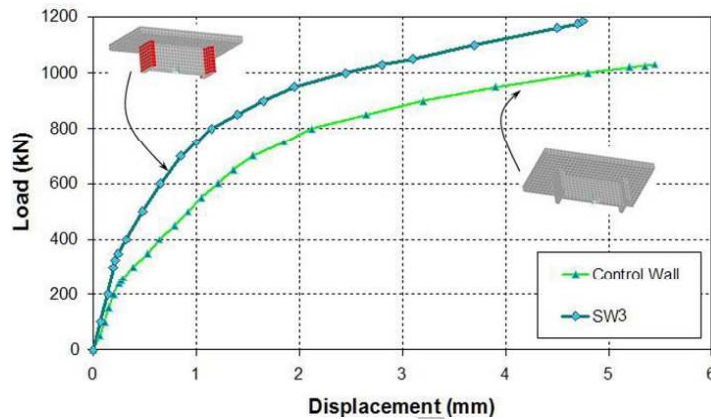

Fig. 11. Comparison of FE analysis load-displacement curves for the “Control wall” and “Strengthened wall with two vertical and one horizontal CFRP layers”

d) Application of CFRP sheets around plastic hinge area

By reviewing the analysis results of strengthened RC walls using externally bonded CFRP sheets on the boundary elements, the SW3 case would be the best model to provide better lateral load capacity and also better ductility, but it still can not satisfy the ductile flexure failure. In order to achieve the ductile flexure failure, one horizontal layer of a CFRP sheet can be wrapped around a plastic hinge (SW4). The Finite Element model of a strengthened wall by externally bonded CFRP sheets in boundary elements and a web of the wall is available in Fig. 12.

Figure 13 shows that the wrapped CFRP sheet around the plastic hinge area of the RC wall provides not only enough shear strength, which results in a ductile flexure failure mode with the concept of strong shear and weak flexure, but also confinement of concrete in the plastic hinge leads to an increase in the ductility of the RC wall. With the confinement of CFRP, a desirable ductile flexural failure mode rather than a brittle shear failure mode can be achieved.

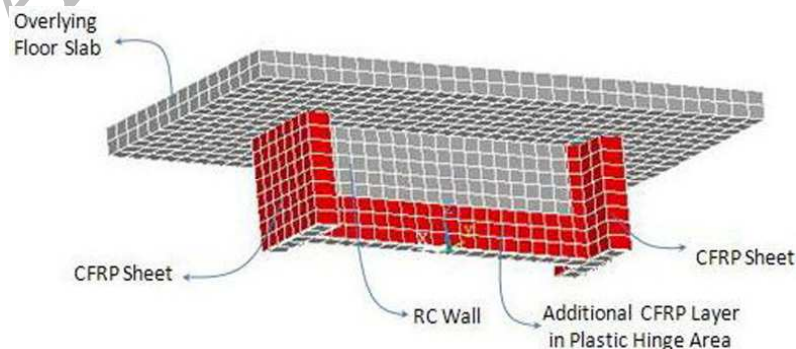

Fig. 12. Finite Element model of strengthened wall by externally bonded CFRP sheets in boundary elements and plastic hinge area of the wall

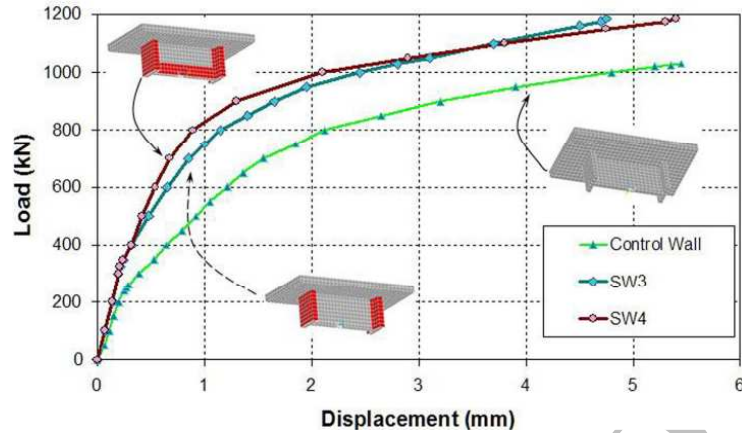

Fig. 13. Comparison of FE analysis load-displacement curves for “Control wall”, “SW3” and “SW4”

6. CONCLUSION

From the results obtained by analyzing different finite element models, the following conclusions can be drawn:

- The main conclusion from the verification against the experimental data is that the Finite Element program can be used to simulate the whole load-deformation curve, i.e., the elastic part, the initiation of cracking, shear cracks and crushing fairly well. However, the determination of the ultimate load is difficult as it is affected by the hardening rule, convergence criteria and iteration method used.
- Three retrofitted RC walls were analyzed using externally bonded steel plates, but after eliminating the over-hanging part of the boundary elements. The results show that a ductile behavior close to the behavior of the RC wall with boundary elements could be achieved from the model with a suitable thickness of steel jacket that leads to the theory that steel jacketing could be an alternative for the boundary elements of RC shear walls.
- Analysis results show that the application of externally bonded carbon fiber sheets is an effective seismic strengthening procedure for RC shear walls. The carbon fiber sheets can be used to increase the precracked stiffness, the cracking load (up to 35%), the yield load and the ultimate flexural capacity (up to 18%) of RC walls.
- The wrapped CFRP sheet around the plastic hinge range of the RC wall provides not only enough shear strength which results in a ductile flexure failure mode with the concept of strong shear and weak flexure, but also the confinement of concrete in the plastic hinge leads to an increase in the ductility of the RC wall. With the confinement of CFRP, a desirable ductile flexural failure mode rather than a brittle shear failure mode can be achieved.

REFERENCES

- Hwang, S. J., Fang, W. H., Lee, H. J. & Yu, H. W. (2001). Analytical model for predicting shear strengths of squat walls. *Journal of Structural Engineering*, ASCE, Vol. 127, No. 1, pp. 43-50.
- Oesterle, R. G., Aristizabal-Ochoa, J. D., Shiu, K. N. & Corley, W. G. (1984). Web crushing of reinforced concrete structural walls. *ACI Structural Journal*, Vol. 81, No. 3, pp. 231-241.

3. Spacone, E. & El-Tawil, S. (2004). Nonlinear analysis of steel-concrete composite structures: state of-the-art. *ASCE Journal of Structural Engineering*. Vol. 130, No. 2, pp. 159-168.
4. ANSYS. *ANSYS User's Manual Revision 9.0*, ANSYS, Inc., USA (2004).
5. Bangash, M. Y. H. (1989). *Concrete and concrete structures: numerical modeling and applications*. Elsevier Science Publishers Ltd., London, England.
6. Hemmaty, Y. (1998). Modeling of the shear force transferred between cracks in reinforced and fiber reinforced concrete structures. *Proceedings of the ANSYS Conference*, Pittsburgh, Pennsylvania, Vol. 1.
7. Huysse, L., Hemmaty, Y. & Vandewalle, L. (1994). Finite element modeling of fiber reinforced concrete beams. *Proceedings of the ANSYS Conference*, Pittsburgh, Pennsylvania, Vol. 2.
8. Kheyroddin, A. (1996). *Nonlinear finite element analysis of flexure dominant-reinforced concrete structures*. Ph.D. thesis, Department of Civil Engineering and Applied Mechanics, McGill University, Montreal, Canada.
9. Barda, F. (1972). *Shear strength of low-rise walls with boundary elements*. Ph.D. Thesis, Lehigh University, Bethlehem, Pennsylvania, USA.
10. Aboutaha, R. S. (1994). *Seismic retrofit of non-ductile reinforced concrete columns using rectangular steel jackets*. PHD dissertation, University of Texas at Austin, p. 373.
11. Aboutaha, R. S., Engelhardt, M. D., Jirsa, J. O. & Kreger, M. E. (1999). Rehabilitation of shear critical columns by use of rectangular steel jackets. *ACI Structural Journal*, Technical Paper/January-February.
12. Gonzalez Cuevas, O. M., Guerrero Correa, J. J., Gomez Gonzalez, B. & Flores Diaz, F. A. (2000). Shear strength of concrete columns with steel jackets. *Proceeding of 12th WCEE Conference*, Newzeland.
13. Sakino, K. & Sun, Y. (2000). Steel jacketing for improvement of column strength and ductility. *Proceeding of 12th WCEE Conference*, Newzeland.
14. Xiao, Y. & Wu, H. (2003). Retrofit of reinforced concrete columns using partially stiffened steel jackets. *ASCE, Journal of Structural Engineering*, Vol. 129, No. 6.
15. Elnashai, A. S. & Pinho, R. (1998). Repair and retrofitting of RC walls using selective techniques. *Journal of Earthquake Engineering*, Vol. 2, No. 4, pp. 525-568.
16. Elnashai, A. S. & Salama, A. I. (1992). Selective repair and retrofitting techniques for RC structures in seismic regions. *Research Report ESEE/92-2*, Engineering Seismology and Earthquake Engineering Section, Imperial College, London, UK.
17. FEMA, (1992). *NEHRP Handbook of Techniques for Seismic Rehabilitation of Existing Buildings*, National Earthquake Hazards Reduction Program, Federal Emergency Management Agency, Building Seismic Safety Council, Washington, D.C., USA.
18. Hiotakis, S., Lau, D. T. & Londono, N. L. (2000). Research on seismic retrofit and rehabilitation of concrete shear walls using FRP materials. Department of Civil and Environmental Engineering, Carleton University, Ottawa, Canada.
19. Lombard, J., Lau, D. T., Humar, J. L., Foo, S. & Cheung, M. S. (2000). Seismic strengthening and repair of reinforced concrete shear walls, *Proceeding of 12th WCEE Conference*, New zeland.
20. Saadatmanesh, H., Ehsani, M. R. & Li, M. W. (1994). Strength and ductility of concrete columns externally reinforced with fiber composite straps. *ACI Structural Journal*, ACI, Vol. 91, No 4, pp. 434-447.
21. Mostofinejad, D. & Talaieitaba, S. B. (2006). Finite element modeling of RC connections strengthened with FRP laminates. *Iranian Journal of Science & Technology, Transaction B*, Vol. 30, No B1, pp. 21-30.