

EXTRACTION OF ZN, MN AND CO FROM ZN-MN-CO-CD-NI CONTAINING SOLUTION USING D2EHPA, CYANEX[®] 272 AND CYANEX[®] 302

D. Darvishi, D. F. Haghshenas, E. Keshavarz Alamdari*

Department of Mining, Metallurgical Engineering, Amirkabir University of Technology,
P.O Box 15875-413 Tehran, Iran
alamdari@aut.ac.ir

S. K. Sadrnezhaad

Department of Materials Science and Engineering, Sharif University of Technology
P.O. Box 11365-9466, Tehran, Iran
sadrnezh@sharif.edu

*Corresponding Author

(Received: January 12, 2008 – Accepted in Revised Form: April 23, 2011)

Abstract Effects of pH, D2EHPA, Cyanex[®] 272 and Cyanex[®] 302 on extraction of zinc, manganese and cobalt from a Zn-Mn-Co-Cd-Ni containing solution at the room temperature was comprehensively investigated. Addition of Cyanex[®] 302 indicated a left-shifting-effect on the extraction curve of zinc, a right-shifting-effect on the extraction curve of manganese and no effect on the extraction of cobalt. Addition of Cyanex[®] 272 shifted all three curves to the right. Therefore, the most suitable extractant for separation of zinc from manganese was therefore 0.3–0.3 mixture of D2EHPA and Cyanex[®] 302, and that for separation of manganese from cobalt was pure D2EHPA. The stoichiometric coefficient for the extraction reaction of zinc (whether using pure D2EHPA or a mixture made of D2EHPA with Cyanex[®] 272 or Cyanex[®] 302) was 3. It varied from 4 to 5 for manganese, when the quantity of Cyanex[®] 302 dissolved in D2EHPA increased from 0 to 100%. Utilizing the above results, a two stage leaching was devised to recover zinc, manganese and cobalt from a complex solution. At the first stage, a 0.6M D2EHPA extractant could recover zinc, and a scrubbing reaction with organic:aqueous (O:A) ratio of 20:1 could wash-out cadmium from the raffinate. In the second stage, the extracting residue was treated with 0.6M D2EHPA for recovery of manganese. This stage was then followed by a one-stage scrubbing of cobalt with O:A ratio of 20:1.

Keywords Solvent Extraction, Zn, Mn, Co, Cd, Ni, D2EHPA, CYANEX[®] 272, CYANEX[®] 302, Stoichiometric Coefficient, Organic Aqueous Solution

چکیده. تاثیر مقدار pH، غلظت حلال‌های آلی D2EHPA، Cyanex[®] 272 و Cyanex[®] 302 بر روی استخراج روی، منگنز و کبالت از محلول آبی حاوی Zn-Mn-Co-Cd-Ni به طور جامع در دمای محیط بررسی شد. افزودن Cyanex[®] 302 باعث جابجایی منحنی استخراج روی و منگنز به ترتیب به چپ و راست می‌شود ولی تاثیری بر روی منحنی استخراج کبالت ندارد. افزودن Cyanex[®] 272 باعث جابجایی منحنی استخراج هر سه فلز به سمت راست می‌شود. ترکیب آلی حاوی 0/3-0/3 D2EHPA و Cyanex[®] 302 شرایط مناسب جداکردن روی را ایجاد می‌کند و با بکارگیری D2EHPA می‌توان کبالت و منگنز را از هم جدا می‌کند. مقدار ضریب استوکیومتری استخراج روی برای D2EHPA خالص یا مخلوط D2EHPA با حلال‌های Cyanex[®] 272 یا Cyanex[®] 302 برابر ۳ است. این مقدار برای منگنز با تغییر نسبت به Cyanex[®] 302 به D2EHPA از ۰ تا ۱۰۰٪ بین ۴ تا ۵ تغییر می‌کند. براساس آنچه که گفته شد بازیابی منگنز و کبالت در دو مرحله جداگانه صورت می‌گیرد. در مرحله اول با استفاده از استخراج کننده D2EHPA با غلظت 0/6 M فلز روی بازیابی می‌شود و بعد از شستشوی فاز آلی با نسبت آبی به آبی (O:A) برابر ۲۰ به ۱ (۲۰:۱) ناخالص کادمیوم حذف می‌شود. در مرحله دوم، باقیمانده مرحله اول نیز با استفاده از استخراج کننده D2EHPA با غلظت 0/6 M فلز منگنز بازیابی می‌شود. با بکارگیری یک مرحله شستشوی فاز آلی با نسبت آبی به آبی (O:A) برابر ۲۰ به ۱ (۲۰:۱) ناخالص فلز کبالت از محلول آلی حذف می‌شود.

1. INTRODUCTION

Various elements are contained in hydrometallurgical liquors obtained from leaching of (a) spent lithium-ion batteries, (b) glass-industry dust waste, (c) copper smelter/converter slag, (d) spent cobalt/manganese bromide oxidation catalyst, (e) spent ammonia cracker catalyst, (f) fly-ash of municipal incineration plants and (g) residues of zinc production plants [1-5]. With the exception of iron that is considered an impurity, cobalt, nickel, manganese, cadmium and zinc are valuable substances that need to be extracted. Liquid-liquid extraction is an efficient way for separation of most of these elements.

The past decade can be considered a great period for separation of troublesome ions. Devi et al [6], for instance, investigated the separation of Mn(II) and Co(II) from sulfate solutions by using sodium salts of D2EHPA, PC 88A and Cyanex® 272 dissolved in kerosene. They found out that 0.05M NaD2EHPA at the equilibrium pH of 4.45 was the most suitable extractant for these elements. Chu Yong Cheng [7] investigated the purification of synthetic laterite leach solution by solvent extraction with D2EHPA. He obtained the following extraction order for seven nonferrous elements at pH_{0.5}:

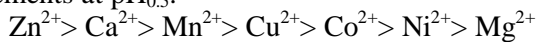

Using constructive McCabe-Thiele diagrams for manganese/cobalt system, Chu Yong Cheng [7] theoretically showed that a two-stage extraction was needed to extract 99.9% manganese from an aqueous solution. This could reduce the manganese concentration from 2.0 g/L to 3 mg/L at a pH of 3.5 and O:A ratio of 1:1.

Hoh et al [8] separated manganese from cobalt in a sulfate solution using D2EHPA diluted by kerosene. They showed that manganese can be separated from cobalt by controlling the aqueous pH equilibrium in the neighborhood of 2.0. These authors indicated that a four-stage extraction process yields a manganese-free aqueous phase. A three-stage extraction process could also result in the removal of nearly all cobalt from the aqueous phase.

Owusu [9] carried out an extraction study on a

bench scale solvent for the recovery of zinc, cadmium and cobalt from mixed electrolyte solutions using 30% V/V D2EHPA plus 4 V/V TBP system. In those experiments, Zn was extracted at a pH of 2.0. The Zn loaded organic solution was scrubbed with ZnSO₄ (30 g/L Zn) at pH of 2.0-2.2, where it contained 0.17 g/L Cd. All Cd was then removed after a single stage scrubbing procedure.

In another work, Elejalde et al [10] recovered heavy metals like Zn, Cu, Co and Mn from some hydrometallurgical effluents by successive solvent extraction processes. They worked with two different procedures using liquid waste from Espinosa Zinc process. Their first method included a two-stage extraction with Amberlite La-2 (a secondary ammine) for Zn and Cu separation followed by three stages with 25 vol. % D2EHPA at a pH value of nearly 1.5, 2.0 and 3.5 for isolating Fe, Mn and Co respectively. Their second method consisted of separating Fe with D2EHPA followed by isolation of Zn by Amberlite La-2.

Devi et al [11] showed that the extracted species during the extraction of divalent zinc and manganese by sodium Cyanex® 272 salts were ZnA₂.3HA and MnA₂.3HA, respectively. Using a developed slope analysis method, Darvishi et al. [12, 13] showed that the dominated complex species, during solvent extraction of Zn and Mn were R₂Zn(RH)_{0.5}H₂O and R₂Mn(RH)₂, respectively.

A most problematic process in Iranian zinc production industry is cobalt recovery from hot filter-pressed cakes. No investigation is reported on this material in the literature. The purpose of this study is, therefore, to investigate the recovery of Zn, Mn and Co from a nickel-cadmium bearing solutions similar to those occurring in Iranian zinc production facilities. The proposed method consists of a two-stage organic/aqueous solvent-extraction procedure: (a) separation of zinc from cadmium and (b) recovery of manganese and cobalt from the remaining solution.

3. EXPERIMENTAL PROCEDURE

2.1. Materials

All materials used in this

research including metal sulfates (Panreac Company, Spain), bis-2- ethylhexylphosphoric acid (D2EHPA) (China), di-2,4,4,-trimethylpentyl phosphinic (Cyanex[®] 272) and di-2,4,4,-trimethylpentyl monothiophosphinic acid (Cyanex[®] 302) (Cytec, Netherlands) and kerosene (Tehran oil refinery, Iran) were of laboratory grade. Distilled water was used to produce 5g/L metal sulfate synthesized solutions.

2.2. Experiments The extraction experiments were carried out with a 0.6M extractant at ambient temperature. An equal-volume (20/20 ml) aqueous/organic mixture was agitated for 30 minutes to approach equilibrium. The mixture was then held at rest so that the phase separation could occur. Concentrations of the ions in the aqueous phase were titrated with EDTA. Eriochrome black T was used as the indicator for zinc and manganese. Murexide was the indicator for cobalt. The organic phase was stripped with 200 g/L sulfuric acid.

3. RESULTS AND DISCUSSION

3.1. Effect of pH Experiments were carried out at room temperature to investigate the effect of pH on the extraction of zinc, manganese and cobalt. The extraction curves of the elements with the mixtures of D2EHPA, Cyanex[®] 302 and Cyanex[®] 272 are shown in Fig. 1. As seen in the figure, increasing Cyanex[®] 302 to D2EHPA shifts the extraction curve of zinc to left and that of manganese to right. However, the experimental points for cobalt coincide, with nearly one extraction curve. The amount of shifting is not the same for different elements and mixtures. Fig. 1a shows that at pH=1 more than 80% zinc can be extracted by utilization of 0.3:0.3 D2EHPA-Cyanex[®] 302. Almost no manganese and cobalt are extracted with the same solution. At the same pH, however, the percentages of zinc and manganese extractable with 0.6M D2EHPA are ~70% and ~8%, respectively (Fig. 1a). It can be concluded that D2EHPA plus Cyanex[®] 302 can separate zinc from manganese and cobalt without any need for

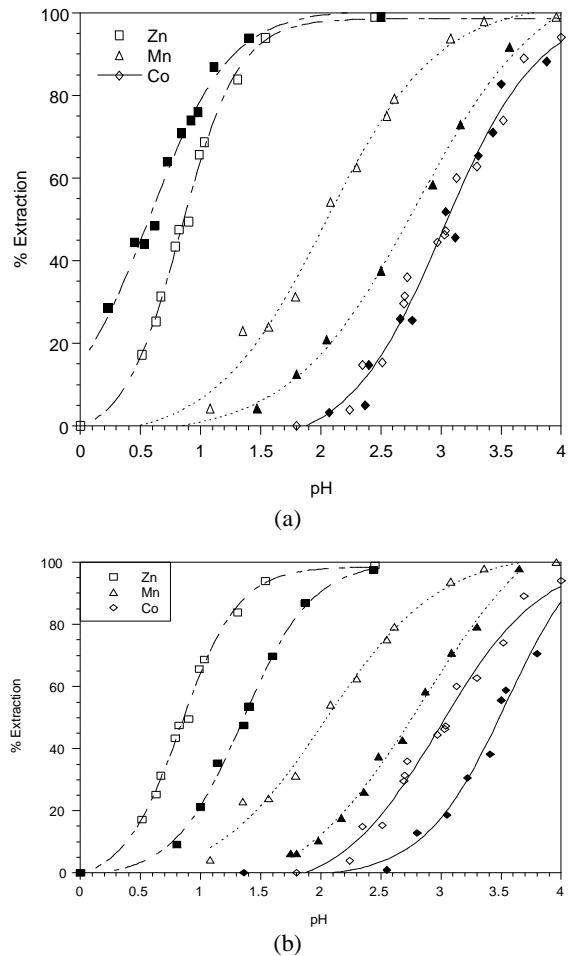

Figure 1. Effect of pH on extraction of zinc, manganese and cobalt. Hollow symbols are related to 0.6 M D2EHPA. Solid symbols correspond to 0.3:0.3 mixture of D2EHPA and Cyanex[®] having a fixed extractant concentration of 0.6 M, for: (a) Cyanex[®] 302 (b) Cyanex[®] 272

further scrubbing stage.

Fig. 1b shows that addition of Cyanex[®] 272 to D2EHPA will shift all three curves to right. At pH=1.5, about 65% zinc extraction is achievable with 0.3:0.3 D2EHPA-Cyanex[®] 272 mixture. Manganese extraction with the same pH is ~3%. Based on the data given in Fig. 1b, at pH=1.5%, ~90% zinc and ~22% manganese are extracted with 0.6M D2EHPA.

By comparing the D2EHPA plus Cyanex[®] 302 or Cyanex[®] 272 mixtures with D2EHPA, one can conclude that the mixture of D2EHPA with Cyanex[®] 302 can separate zinc better than other extractants investigated.

The data obtained for $pH_{0.5}$ (pH at 50% metal extraction) and $\Delta pH_{0.5}$ (the $pH_{0.5}$ differences of the two metals) of the zinc, manganese and cobalt are listed in Table 1.

3.2. Separation of zinc from manganese

Fig. 1 shows that Cyanex[®] 272 or Cyanex[®] 302 to D2EHPA increases the $\Delta pH_{0.5}$ of zinc and manganese. One can attribute the selectivity of zinc and manganese to the differences between the $pH_{0.5}$ values of the two metals. Hence the data presented in Table 1 indicates that the 0.3–0.3 D2EHPA-Cyanex[®] 302 mixture is the most suitable extractant for separation of manganese from zinc.

3.3. Separation of manganese from cobalt

The results obtained from the $\Delta pH_{0.5}$ of cobalt and manganese is in contrast to that obtained from zinc and manganese (Table 1). Adding Cyanex[®] 272 or Cyanex[®] 302 to D2EHPA decreases the $\Delta pH_{0.5}$ of cobalt and manganese. However, the best result

manganese extraction selectivity The separation factor (β) of two elements A and B is defined as:

$$\beta_{A/B} = \frac{D_A}{D_B} \tag{1}$$

where the distribution coefficient, D, is defined as follows:

$$D = \frac{\sum [M_{org}]}{\sum [M_{aq}]} \tag{2}$$

The factor (β) is considered as a selectivity measure in the metal extraction systems. In solutions containing two metallic ions, the distribution ratio has a similar role. A greater separation factor indicates a better partitioning; i.e. a more selective extraction.

The effect of pH on quantities of $\beta_{Mn/Co}$ and $\beta_{Zn/Mn}$ is shown in Tables 2 and 3, respectively. It is seen that the selectivity of zinc over manganese improves when using D2EHPA-Cyanex[®] 302 instead of D2EHPA-Cyanex[®] 272 or D2EHPA alone. In the pH range 1.4-2.2, the value of $\beta_{Zn/Mn}$

TABLE 1. Values of $pH_{0.5}$ for different D2EHPA to Cyanex[®] ratios at 25 °C.

[D2EHPA]: [Cyanex [®]]	$pH_{0.5}$			$\Delta pH_{0.5}$		
	Zn	Mn	Co	Mn-Zn	Co-Mn	
272	0.6:0.0	0.87	2.05	3.04	1.18	0.99
	0.5:0.1	1.08	2.07	3.25	0.99	1.18
	0.4:0.2	1.17	2.28	3.39	1.11	1.11
	0.3:0.3	1.35	2.76	3.48	1.41	0.72
302	0.6:0.0	0.87	2.05	3.04	1.18	0.99
	0.5:0.1	0.70	2.18	3.11	1.48	0.93
	0.4:0.2	0.61	2.43	3.11	1.82	0.68
	0.3:0.3	0.57	2.74	3.13	2.17	0.37

TABLE 2. Values of $\beta_{Mn/Co}$ for different mixtures of D2EHPA with Cyanex 302, D2EHPA with Cyanex 272 and individual D2EHPA.

pH	D2EHPA/Cyanex 302			D2EHPA/Cyanex 272			Individual D2EHPA		
	D_{Mn}	D_{Co}	$\beta_{Mn/Co}$	D_{Mn}	D_{Co}	$\beta_{Mn/Co}$	D_{Mn}	D_{Co}	$\beta_{Mn/Co}$
1.8	0.13	0.00	-	0.07	0.00	-	0.56	0.00	-
2.0	0.20	0.03	6.33	0.14	0.00	-	0.89	0.02	44.50
2.2	0.33	0.07	4.71	0.26	0.01	26.00	1.42	0.07	20.29
2.4	0.50	0.15	3.33	0.42	0.03	14.00	2.20	0.15	14.67
2.6	0.78	0.28	2.79	0.68	0.05	13.60	3.50	0.28	12.50
2.8	1.18	0.49	2.41	1.11	0.11	10.09	5.86	0.49	11.96
3.0	1.82	0.87	2.09	1.89	0.21	9.00	9.66	0.87	11.10
3.2	2.95	1.48	1.99	3.17	0.41	7.73	16.97	1.48	11.47

TABLE 3. Values of $\beta_{Zn/Mn}$ for different mixtures of D2EHPA with Cyanex 302, D2EHPA with Cyanex 272 and individual D2EHPA.

pH	D2EHPA/Cyanex 302			D2EHPA/Cyanex 272			D2EHPA		
	D _{Zn}	D _{Mn}	$\beta_{Zn/Mn}$	D _{Zn}	D _{Mn}	$\beta_{Zn/Mn}$	D _{Zn}	D _{Mn}	$\beta_{Zn/Mn}$
1.4	13.89	0.05	277.80	1.17	0.00	-	7.32	0.21	34.86
1.6	25.18	0.08	314.75	2.37	0.02	118.50	11.82	0.35	33.77
1.8	56.47	0.13	422.10	4.66	0.06	77.67	30.45	0.55	54.91
2.0	141.86	0.21	675.30	9.47	0.14	67.64	46.17	0.89	52.06
2.2	284.72	0.33	870.32	19.20	0.26	73.85	69.42	1.42	48.95
2.4				39.32	0.42	93.62			
2.6				69.42	0.68	102.09			
2.8				139.85	1.13	123.76			
3.0				276.78	1.89	146.44			

3.5. Mechanism of zinc and manganese extraction The stoichiometric coefficients of the extraction reactions are required to determine the mechanism of the extraction processes. The zinc and manganese extraction reactions can be shown as follows:

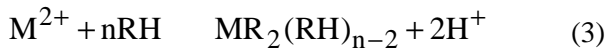

The equilibrium constant of the reaction is as follow:

$$K = D_M \times \frac{[H^+]_{equ}^2}{[RH]_{equ}^n} \quad (4)$$

where D_M is the distribution coefficient given by:

$$\frac{[MR_2(RH)_{n-2}]}{[M^{2+}]} \quad (5)$$

The following expression can be derived from equation 4:

$$\log D_M = \log K + 2pH + n \log [RH]_{equ} \quad (6)$$

Considering the amount of the extracted element, concentration of the extractant at equilibrium would be given by:

$$[RH]_{equ} = 0.6 - n \times \frac{\%E \times C_o}{M_W \times 100} = 0.6 - n[M]_{org} \quad (7)$$

where:

n = the stoichiometric coefficient of the extractant

$\%E$ = the extraction percent

C_o = the initial concentration of the species being extracted, g/L

M_W = the atomic weight of M

$[M]_{org}$ = the metal contained in the organic phase

Combining equations 6 and 7, gives:

$$\log D_M = n \log [0.6 - n[M]_{org}] + \log K + 2pH \quad (8)$$

The stoichiometric coefficient of the extractant, n , can be calculated by trial and error evaluations. For a constant value of K , plotting $(\log D_M - n \log [RH]_{equ})$ against pH must give a straight line regardless of the value of n . Different slopes and intercepts may be obtained by assigning different values to n (Fig. 2). Only one value corresponds with the correct equation (equation 6). The line with slope 2 is correct for both zinc and manganese. This gives the stoichiometric coefficient of the extractant. Fig 2a shows the values of n for zinc extraction with 0.3:0.3 D2EHPA-Cyanex[®] 302 to be 3. Based on the data of Fig. 2b, the value of n for manganese extraction with 0.3:0.3 D2EHPA-Cyanex[®] 302 is 5.

Based on the results obtained from the slope analysis of Fig. 2 curves, the extraction equation of zinc and manganese can be presented as follows:

a. For D2EHPA and its mixture with Cyanex[®] 272:

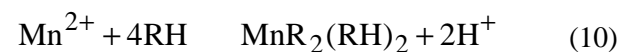
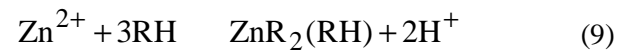

b. For mixture of D2EHPA and Cyanex[®] 302:

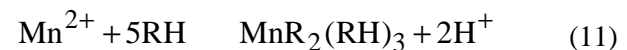

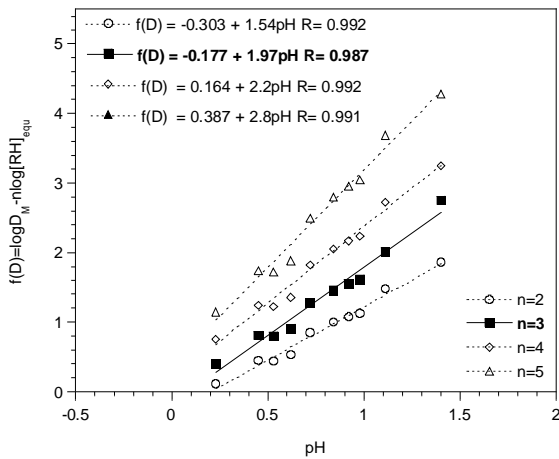

(a)

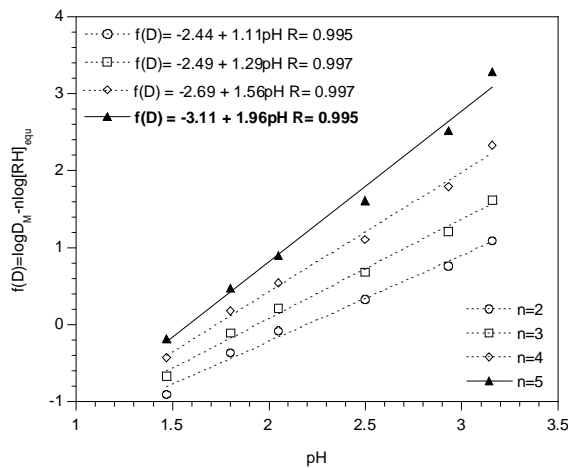

(b)

Figure 2. Effect of pH on variation of $\log D_M - n \log [RH]_{equ}$ versus pH. The data are for 0.3-0.3 D2EHPA-Cyanex® 302 used for extraction of: (a) Zinc and (b) Manganese

3.6. Extraction isotherm McCabe-Thiele plot was constructed at 0.6M D2EHPA with $pH = 1.5$ to estimate the number of stages required for isothermal zinc extraction (Fig. 3). Following and based on the results of our previous work [14], the concentration of zinc in the filter-cake leaching liquor was about 22 g/L. Fig. 3 shows that an organic phase loaded with up to 11 g/L zinc results in an aqueous concentration of less than 0.07 g/L after three extraction stages.

McCabe-Thiele plot was also constructed at 0.6 M D2EHPA with pH of 2.6 to estimate the number of stages required for isothermal manganese

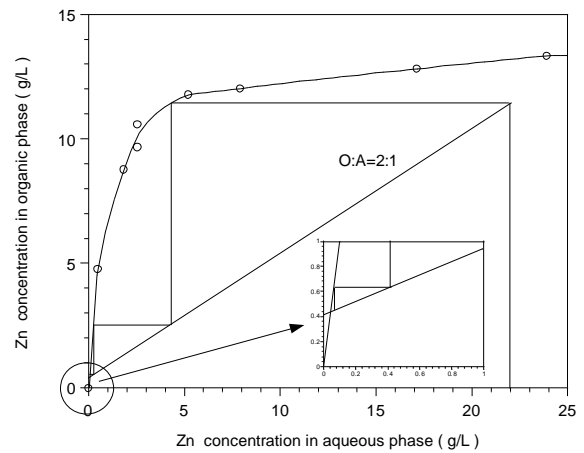

Figure 3. Thiele plot for extraction of zinc using 0.6 M D2EHPA at pH of 1.5

extraction (Fig. 4). Based on the results obtained from leaching of the filter cake residue, the concentration of manganese in leaching liquor was about 16 g/L. Manganese extraction occurred at three stages where the O:A ratio was 3:1. The data plotted in Fig. 4 shows that the organic phase was loaded with manganese up to 5.4 g/L after three stages, while the raffinate was completely depleted.

3.7. Scrubbing stage The purpose of scrubbing is to wash-out any metallic impurities co-extracted with the base metal. An extractable impurity was cadmium [9, 15-16]. Since co-leaching of

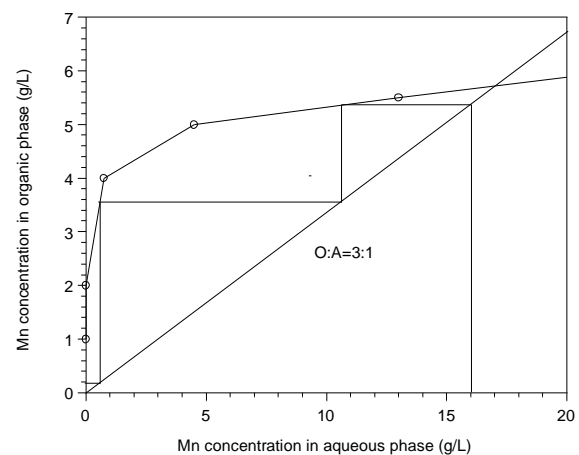

Figure 4. Thiele plot for extraction of manganese using 0.6 M D2EHPA, at pH of 2.6.

cadmium with zinc was insignificant, co-extraction of cadmium with zinc did not seem feasible. Experiments were, therefore, carried out for scrubbing and recycling of cadmium from the bed solution.

The scrubbing McCabe-Thiele plot of cadmium from zinc is shown in Fig. 5. The aqueous solution contained 45 and 40 g/L of zinc and sulfuric acid, respectively. According to the McCabe-Thiele extraction plot, the organic phase was loaded with up to 11 g/L of zinc. This phase contained more than 100 mg/L cadmium. At O:A ratio of 20:1, one stage was enough to scrub cadmium from the organic phase. Concentration of zinc was almost unchanged (11 g/L), and cadmium was completely rejected to raffinate (less than 5 mg/L).

The scrubbing McCabe-Thiele plot of cobalt from manganese is shown in Fig. 6. The aqueous solution contained 100 g/L of manganese and 0 g/L of sulfuric acid. The organic phase was loaded with up to 6 g/L of manganese. The organic phase was also contaminated with cobalt to amounts greater than 200 mg/L. Results showed that one stage was required to scrub cobalt from the organic phase at O:A ratio of 20:1. After one stage scrubbing, the concentration of cobalt reduced from 1000 to less than 2 mg/L. In the case of manganese, no concentration change was observed.

3.8. Stripping stage The stripping isotherm for zinc loaded D2EHPA is plotted in Fig. 7. Based on McCabe-Thiele extraction isotherm, the acid

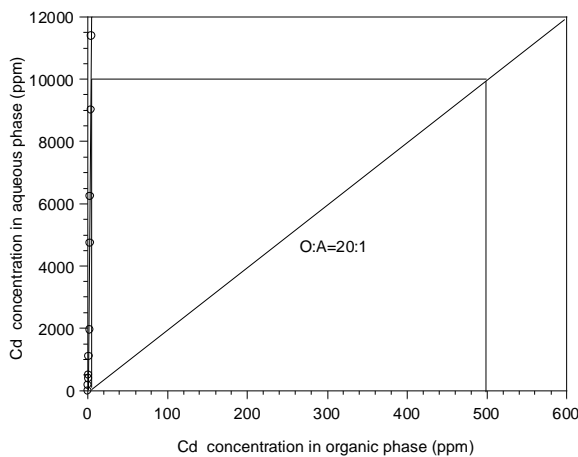

Figure 5. McCabe-Thiele plot for scrubbing of cadmium from zinc.

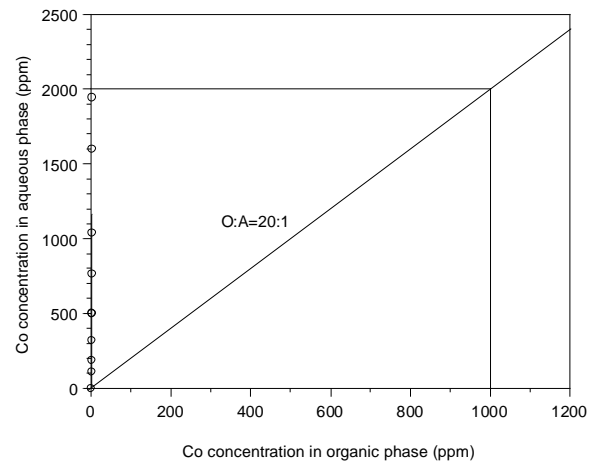

Figure 6. McCabe-Thiele plot for scrubbing of cobalt from manganese.

concentration was chosen to be equal to 150 g/L and organic phase was loaded with up to 11 g/L. According to Fig 7, two stages are required to strip zinc from organic phase with O:A ratio of 5:1. The operation line has an intercept of ~35. The stripping phase provided to the zinc recovery unit has a concentration of 40 g/L.

The stripping isotherm for D2EHPA loaded with manganese is shown in Fig. 8. The concentration of acid was 180 g/L and the organic phase was loaded to ~5 g/L. According to the McCabe-Thiele plot of manganese with O:A ratio of 20:1, only one stage was required to strip all of manganese from the organic phase.

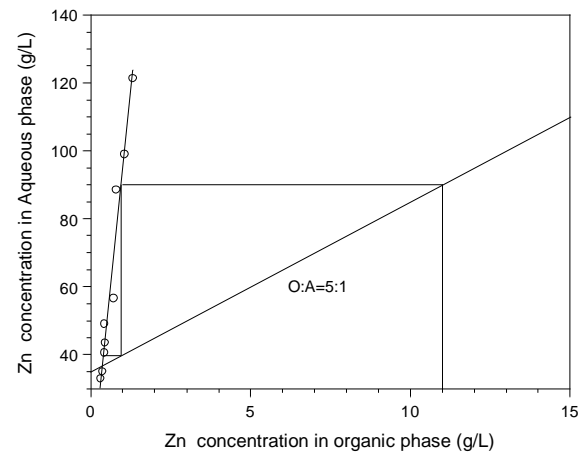

Figure 7. McCabe-Thiele plot for stripping of zinc loaded D2EHPA using 150 g/L H₂SO₄.

The stripping isotherm for D2EHPA loaded with manganese is shown in Fig. 8. Concentration of acid was 180 g/L and the organic phase was loaded to ~5 g/L. According to the McCabe-Thiele plot of manganese with O:A ratio of 20:1, only one stage was required to strip all manganese from the organic phase.

An overall flow sheet for recovery of zinc, manganese and cobalt is presented in Fig. 9. The flow sheet indicates separate sections showing recovery processes of zinc and manganese. The zinc-recovery section includes a filter-cake leaching process with sulfuric acid followed by zinc extraction. The leach liquor contains zinc, cadmium and nickel. Zinc is separated from cadmium and nickel at pH of 1.5 by 0.6 M D2EHPA. Cadmium and nickel could then be recovered by recycling the raffinate to the cementation unit. Loaded organic is piped to

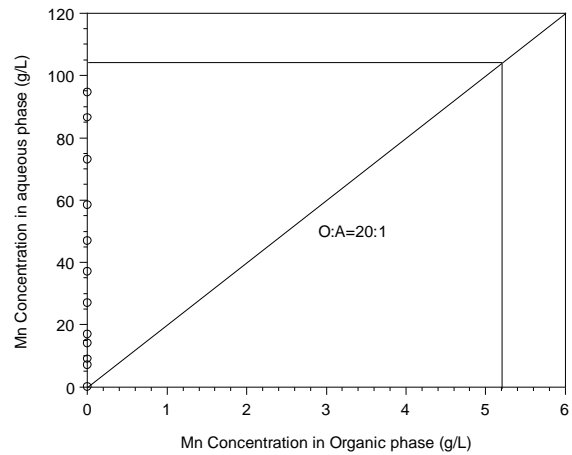

Figure 8. McCabe-Thiele plot for stripping of manganese loaded D2EHPA using 180 g/L H₂SO₄.

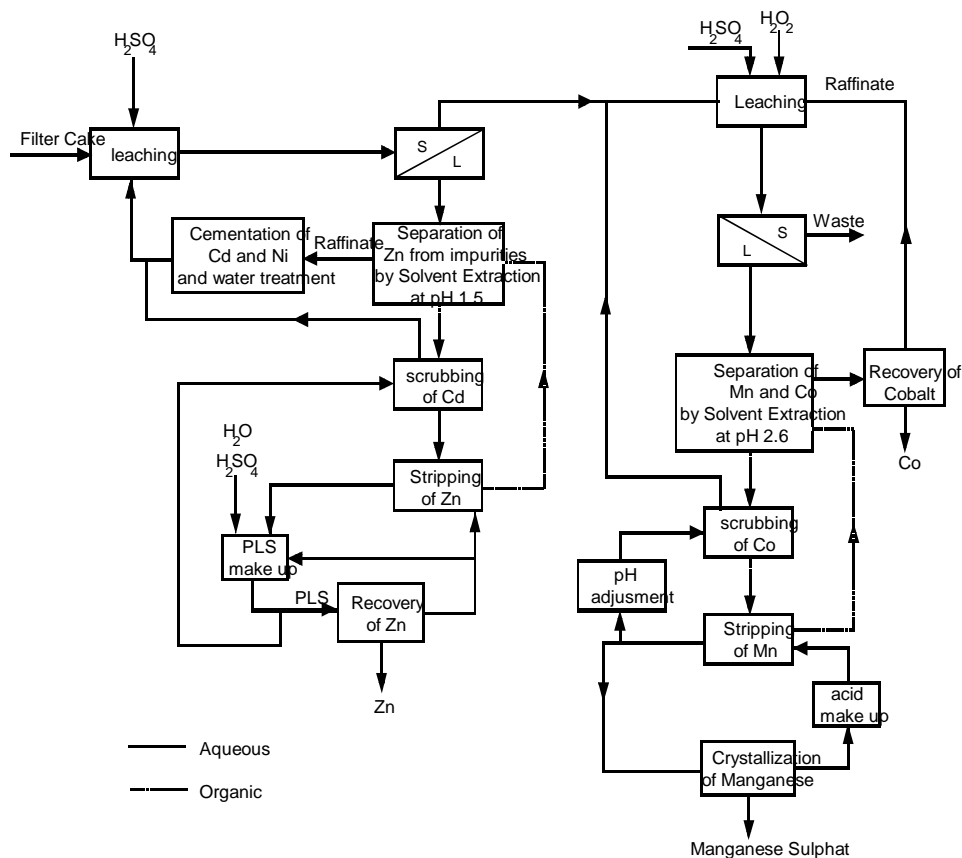

Figure 8. D2EHPA with Cyanex 272 and individual D2EHPA. Overall flow sheet for recovery of zinc and manganese

scrubbing unit in order to wash out cadmium. Purified organic solution is then stripped. The pregnant liquor solution (PLS) is recycled to the zinc recovery unit after its making up process.

The residue of the first stage is leached again by sulfuric acid and hydrogen peroxide (H₂O₂). The leach liquor obtained contains Mn, Co and impurities like Zn, Ni and Cd. Manganese could be separated from cobalt by solvent extraction at pH of 2.6. The raffinate is used to recover cobalt. Impurities co-extracted with Mn like Ni, Cd and Co are then scrubbed in order to wash them out from the organic phase. The aqueous feed for scrubbing is provided as raffinate of the stripping process treated to adjust pH. The purified organic solution is then exposed to the stripper. After stripping of manganese, large amounts of raffinate are treated to produce manganese sulphate through crystallization process.

4. CONCLUSIONS

The extraction of zinc, manganese and cobalt increases with pH. Equilibrium pH is lowest for extraction of zinc and highest for cobalt. A mixture of D2EHPA and Cyanex[®] 302 with the ratio of 0.3:0.3 with a maximum $\Delta\text{pH}_{0.5}$ value of 2.17 is the most suitable extractant for separation of manganese from zinc. D2EHPA with a concentration of 0.6 M is the best extractant for separation of manganese from cobalt. For separation of zinc and manganese, 0.6 M D2EHPA is the best.

With pure D2EHPA, the stoichiometric coefficient of the extractant in the manganese extraction equation is 4. Adding Cyanex[®] 302 to D2EHPA changes this stoichiometric coefficient from 4 to 5. For Cyanex[®] 272, no change is observed. The stoichiometric coefficient of extractant in zinc extraction equation is 3 when using D2EHPA or D2EHPA with Cyanex 272 or Cyanex 302 mixtures.

In order to recover zinc and manganese, a two-stage leaching process is feasible. The leaching liquor of the first stage which contains zinc, cadmium and nickel can be used to recover zinc from cadmium/nickel by utilization of 0.6M D2EHPA. This is followed by a one stage scrubbing at O:A ratio of 20:1, so that cadmium

wash-out can occur. Six steps, in total, are required: three for extraction, one for scrubbing and two for stripping of the solution.

The residue of the first leaching stage is treated with 0.6M D2EHPA followed by a one-stage cobalt wash-out scrubbing process to recover manganese. An O:A ratio of 20:1 is used in this stage. Five steps, in total, are needed: three for extraction, one for scrubbing and one for the stripping process. Experimental results show that a one-stage scrubbing process yields a cadmium-free and a zinc-full organic phase. The one-stage scrubbing process in manganese recovery procedure removes cobalt from the organic phase.

6. REFERENCES

1. Senanayake, G., Shin, S-M., Senaputra, A., Winn, A., Pugaev, D., Avraamides, J., Sohn, J-S., Kim, D-J., "Comparative leaching of spent zinc-manganese-carbon batteries using sulfur dioxide in ammoniacal and sulfuric acid solutions", *Hydrometallurgy*, Vol. 105, (2010), 36-41
2. Sadegh Safarzadeh, M., Bafghi, M.S., Moradkhani, D., Ojaghi Ilkhchi, M., "A review on hydrometallurgical extraction and recovery of cadmium from various resources", *Minerals Engineering*, Vol. 20, (2007), 211-220
3. Sadegh Safarzadeh, M., Moradkhani, D., Ojaghi Ilkhchi, M., Hamedani Golshan, N., "Determination of the optimum conditions for the leaching of Cd-Ni residues from electrolytic zinc plant using statistical design of experiments", *Separation and Purification Technology*, Vol. 58 (2008), 367-376
4. Sadegh Safarzadeh, M., Moradkhani, "The effect of heat treatment on selective separation of nickel from Cd-Ni zinc plant residues", *Separation and Purification Technology*, Vol. 73 (2010) 339-341
5. Haghshenas, D. F., Darvishi, D., Etemadi, S., Eivazi Hollagh, A.R., Keshavarz Alamdari, E., Salardini, A.A., "Interaction between TBP and D2EHPA during Zn, Cd, Mn, Cu, Co and Ni solvent extraction: A thermodynamic and empirical approach", *Hydrometallurgy*, Vol. 98 (2009), 143-147
6. Devi, N. B., Nathsarma, K.C., Chakravorty, V., "Separation of divalent manganese and cobalt ions from sulphate solutions using sodium salts of D2EHPA", PC 88A and Cyanex 272", *Hydrometallurgy*, Vol. 54 (2000), 117-131.
7. Cheng, C. Y., "Purification of synthetic laterite leach solution by solvent extraction using D2EHPA", *Hydrometallurgy*, Vol. 56 (2000), 369-386
8. Hoh, Y.C., Chuang, W.S., Lee, B. D., Chang, C. C., "The separation of manganese from cobalt by

9. Owusu, G., "Selective extractions of Zn and Cd from Zn-Cd-Co-Ni sulphate solution using di-2-ethylhexyl phosphoric acid extractant". *Hydrometallurgy*, Vol. 47 (1998), 205-215.
10. Elejalde, C., Romero, F., Díaz, J. M., "Separation and recovery of heavy metals from hydrometallurgical effluents by solvent extraction". *Analytical and Bioanalytical Chemistry*, Vol. 340 (1991), 182-185.
11. Devi, N.B., Nathsarma, K. C., Chakravorty, V., "Extraction and separation of Mn(II) and Zn(II) from sulphate solutions by sodium salt of Cyanex 272". *Hydrometallurgy*, Vol. 45 (1997), 169-179
12. Darvishi, D., Haghshenas, D. F., Etemadi, S., A.R., Keshavarz Alamdari, Sadrnezhad, S.K., "Water adsorption in the organic phase for the D2EHPA-kerosene/water and aqueous Zn²⁺, Co²⁺, Ni²⁺ sulphate systems". *Hydrometallurgy*, Vol. 88 (2007), 92-97.
13. Darvishi, D., Teimouri, M., Keshavarz Alamdari, E., Haghshenas, D.F., "Extraction of manganese from solutions containing zinc and cobalt by D2EHPA and of D2EHPA-Cyanex 272 or D2EHPA-Cyanex 302 Mixtures". *Proceeding of International Solvent Extraction Conference (ISEC) Beijing, China*. (2005)
14. Haghshenas, D. F., Darvishi, D., Mos'hefi Shabestari, Z., Keshavarz Alamdari, E., Sadrnezhad, S. K., "Leaching recovery of zinc, cobalt and manganese from zinc purification residue". *International Journal of Enginnering*, Vol. 20 (2007), 133-139
15. Nagaosa, Y., Binghua, Y., "Extraction equilibria of some transition metal ions by bis(2-ethylhexyl) phosphinic acid". *Talanta*, Vol. 44 (1997), 327-337.
16. Keshavarz Alamdari, E., Moradkhani, D., Darvishi, D., Askari, M., Behnian, D., "Synergistic effect of MEHPA on co-extraction of zinc and cadmium with DEHPA". *Minerals Engineering*, Vol. 17 (2004), 89-92.