

## INTELLIGENT TECHNIQUE OF CANCELING MATERNAL ECG IN FECG EXTRACTION

C. KEZI SELVA VIJILA AND P. KANAGASABAPATHY

**ABSTRACT.** In this paper, we propose a technique of artificial intelligence called adaptive neuro fuzzy inference system (ANFIS) for canceling maternal electrocardiogram (MECG) in fetal electrocardiogram extraction (FECG). This technique is used to estimate the MECG present in the abdominal signal of a pregnant woman. The FECG is then extracted by subtracting the estimated MECG from the abdominal signal. Performance of the proposed method in terms of mean square error, signal to noise ratio is compared with neural network. Our results show that this method is a simple and powerful means for the extraction of FECG.

### 1. Introduction

The analysis of the fetal heart rate (FHR) has become a routine procedure for the evaluation of the well-being of the fetus. Factors affecting FHR are uterine contraction, baseline variability, hypoxia and oxygenation. It has many drawbacks such as position-sensitivity, signal drop out, frequent confusion between maternal heart rate and fetal heart rate, failure in obese patients which in turn increases the rate of cesarean sections due to over diagnosis of fetal distress, misinterpretation of cardiotocogram traces and failure to act in time. FECG measurement is used to overcome all these limitations. FECG is useful to get reliable information on fetal status, the detection of abnormalities and monitorization task during labor, to enable the adoption of measures for assuring fetal wellbeing, to detect whether the fetus is alive or dead, and to determine twin pregnancies [7]. The diagnostic tests of fetal well-being can be categorized as invasive and noninvasive. During delivery, accurate recordings can be made by placing an electrode on the fetal scalp. However, as long as the membranes protecting the child are not broken, one should look for noninvasive techniques [12].

Some of the problems that limit the application of non-invasive fetal electrocardiography are low-level signals in a background of noise with a poor signal-to-noise ratio (SNR), no standard electrode positioning for optimizing acquisition, and the shape of the signal that depends on the position of the

---

Received: May 2006; Revised: October 2006; Accepted: May 2007

*Key words and phrases:* Interference cancellation, Neuro fuzzy logic, Fetal ECG extraction

electrodes and the gestational age[7]. Moreover, electrode output from the abdomen is hampered by MECG, electromyogram due to uterus contraction and respiration, power line interference and thermal noise from electronic equipments. The main source of interference is MECG, the amplitude of which is much higher than that of the fetus and the latter is most often completely masked by the former. Our main aim is therefore to eliminate the MECG. In this sense, there are a number of methods for separating the MECG from the FECG, such as direct subtraction, techniques based on temporal or spatial filtering which suffer from the physical limitation of placing a large number of electrodes in the same region, subtraction of an averaged pattern which takes longer acquisition time and also requires many samples, adaptive impulse correlated filter which requires the accurate replica of the interference etc. Conventional frequency selective filtering is not used in FECG extraction because FECG bandwidth is between 0.05 and 100Hz, amplitude is very low compared to MECG and the spectra of both signals overlap [2]. In adaptive filters, it is difficult to choose the length and adaptation constant of least mean square (LMS) algorithm also it fails to yield good result in the case of canceling nonlinear and nonstationary interferences. Recursive least square (RLS) algorithm increases the computational complexity. Kalman Filter is useful for noise cancellation only in the case of linear systems. Many papers have been presented on FECG extraction using blind source separation (BSS) and wavelet transform. In [8] and [12], authors have explored the feasibility of applying independent component analysis (ICA) to data recorded by electrocardiographic electrodes applied on the mother's abdomen. In such configuration the application of ICA may face limitations due to problems inherently related to tissue conductivity, electrode efficiency, and other factors that may cause the signal mixture at the sensors to be non instantaneous [10]. It also requires multiple leads for successful separation of the FECG. It can be overcome by polynomial network which is based on nonlinear mapping between the abdominal and the MECG signal [1]. Source separation in the wavelet domain introduces the permutation problem, which is a well known limitation of transform domain BSS, particularly for convolutive mixtures, for which the separation matrix will be different in each subband, while in the case of instantaneous mixtures the mixing is in effect identical in each subband. In [3], the outputs from the wavelet transform are concatenated, so as to form a single vector for source separation. The greatest disadvantage of performing source separation on the concatenated coefficients is the introductions of discontinuities, which result in fluctuations and absence of excitation in places, hence causing the adaptive process to slow down or even terminate at times. Despite the reported successes of these methods, they are still not used clinically on a large scale. In [1], authors have chosen 2 signals for analyses based on the visual observations made on the signals, such as whether the signals have stronger FECG or MECG components. Practically, it is difficult to predict the signal components in the abdominal signals. Comparison is made between polynomial network and ANFIS in [2].

In this paper, we propose neuro fuzzy logic technique to cancel the MECG. It combines the advantages of neural network and fuzzy logic technique. Due to the adaptation capability of neural network, even if we have a single reference signal without considering the sensitivity of the electrode position, it is possible to estimate the MECG present in the abdominal signal. Since neural network takes longer time for convergence, we have combined the fuzzy logic technique for decision making and verification purposes. In order to prove the efficiency of the proposed technique, experiments were carried out with the simulated signals using conventional methods of LMS filter, adaptive neural networks and ANFIS [11]. From the results obtained through these techniques, we infer that ANFIS cancels out the interference and gives better performance even if the complexity of the signal is very high. The characteristics of the real MECG and abdominal signals are different from the simulated signals like sine wave and random wave. Hence, in this paper, we consider the real MECG and abdominal signals. The results obtained with this method are visually compared with the previous methods and we have found that we could extract the FECG signal with less computational time.

The paper is organized as follows. Section 2 describes the concept of canceling the MECG. The proposed technique is explained in section 3. The performance of the proposed technique is shown in section 4. Conclusions are drawn in section 5.

## 2. Method of MECG Cancellation

The method used in this paper is adaptive noise cancellation (ANC) based on neuro fuzzy logic technique. ANC is a process by which the interference signal can be filtered out by identifying a non linear model between a measurable noise source (MECG) and the corresponding immeasurable interference [6]. This is an extremely useful technique when a signal is submerged in a very noisy environment. Usually, the MECG noise is not steady; it changes from time to time. So the noise cancellation must be an adaptive process: it should be able to work under changing conditions, and be able to adjust itself according to the changing environment. The basic idea of an adaptive noise cancellation algorithm is to pass the corrupted signal (abdominal) through a filter that tends to suppress the MECG while leaving the signal unchanged. As mentioned above, this is an adaptive process, which means it does not require prior knowledge of signal or noise characteristics. Figure 1 shows noise cancellation with ANFIS filtering.

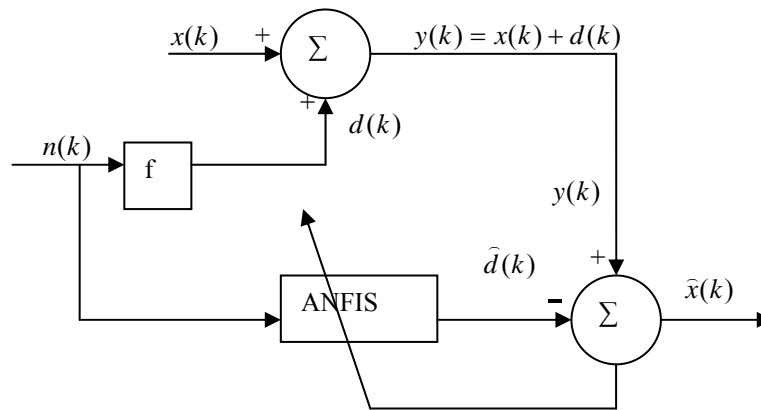

FIGURE 1. Schematic diagram of Adaptive Noise Cancellation using neuro fuzzy logic technique.

In this paper,  $x(k)$  represents the FECG signal which is to be extracted from the noisy signal.  $n(k)$  is the MECG which is the noise source signal. The noise signal goes through unknown nonlinear dynamics ( $f$ ) and generates a distorted noise  $d(k)$ , which is then added to  $x(k)$  to form the measurable output signal (abdominal)  $y(k)$ . The aim is to retrieve  $x(k)$  from the measured signal  $y(k)$  which consists of the required signal  $x(k)$  plus  $d(k)$ , a distorted and delayed version of  $n(k)$  i.e. the interference signal. In symbols, the measured signal is expressed as

$$y(k) = x(k) + d(k) = x(k) + f(n(k), n(k-1), n(k-2), \dots) \quad (1)$$

The function  $f(\cdot)$  represents the passage dynamics (mother's body) that the noise signal  $n(k)$  goes through. If  $f(\cdot)$  was known exactly, it would be easy to recover  $x(k)$  by subtracting  $d(k)$  from  $y(k)$  directly. However,  $f(\cdot)$  is usually unknown in advance and could be time-varying due to changes in the environment. Moreover, the spectrum of  $d(k)$  may overlap with that of  $x(k)$  substantially, invalidating the use of common frequency domain filtering techniques. To estimate the interference signal  $d(k)$ , we need to pick up a clean version of the noise signal  $n(k)$  that is independent of the required signal. However, we cannot access  $d(k)$  directly since it is an additive component of the overall measurable signal  $y(k)$ . In Figure 1, ANFIS is used to estimate the unknown interference  $\hat{d}(k)$ . When  $\hat{d}(k)$  and  $d(k)$  are close to each other, these two get cancelled and we get the estimated output signal  $\hat{x}(k)$  which is close to the required signal (FECG).

### 3. Adaptive Neuro Fuzzy Inference System

ANC using linear filters have been used successfully in real world applications such as interference canceling in Electrocardiograms, echo elimination on long distance telephone transmission lines, and antenna side lobe interference canceling. This concept of linear adaptive noise cancellation can be extended to non-linear realms by using nonlinear adaptive systems. Thus, ANFIS, which is one such nonlinear adaptive system is proposed in this paper, to estimate an unknown interference present in the FECG signal.

Over the last few decades, neural networks and fuzzy systems have established their reputation as alternative approaches to signal processing. Both have certain advantages over conventional methods, especially when vague data or prior knowledge is involved. However, their applicability suffered from several weaknesses of the individual models. Neural networks recognize patterns and adapt themselves to cope with changing environments. Fuzzy inference systems (FIS) incorporate human knowledge and perform inferencing and decision-making. ANFIS takes the advantages of the combination of neural network and fuzzy logic [6]. The basic idea of combining fuzzy systems and neural networks is to design an architecture that uses a fuzzy system to represent knowledge in an interpretable manner, in addition to possessing the learning ability of a neural network to optimize its parameters. The drawbacks of both of the individual approaches - the black box behavior of neural networks, and the problems of finding suitable membership values for fuzzy systems - could thus be avoided.

**3.1. Membership Function Used in ANFIS.** A membership function (MF) is a curve that defines how each point in the input space is mapped to a membership value (or degree of membership) between 0 and 1 [6]. In this paper, we have used generalized bell type MF for tuning the FIS parameters. This is shown in Figure 2. It is specified by three parameters namely  $a_i$ ,  $b_i$  and  $c_i$  represents the width, centre and slope of the curve, and it is given by

$$\mu_A(x) = \frac{1}{1 + \left| \frac{x - c_i}{a_i} \right|^{2b}} \quad (2)$$

As the values of these parameters change, the bell shaped functions vary accordingly. It has the advantage of smoothness and concise notation.

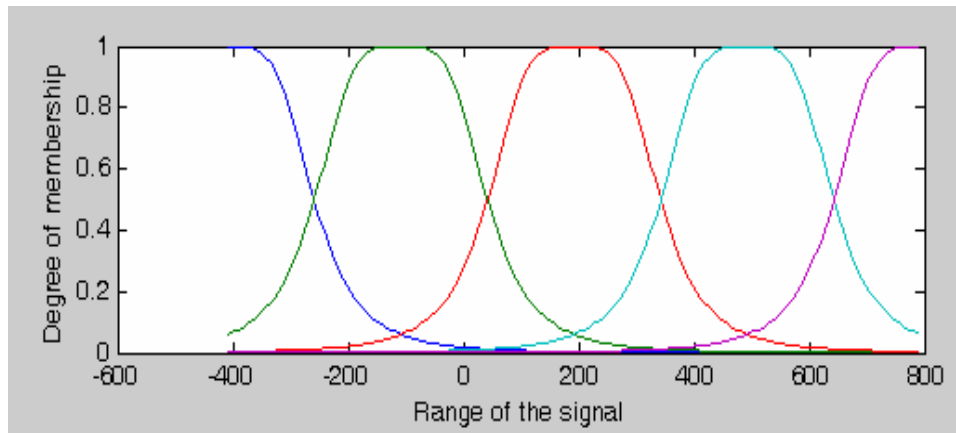

FIGURE 2. Bell shape membership function.

**3.2. FIS Structure and MF Parameter Adjustment.** The basic structure of a fuzzy inference system maps input characteristics to input membership functions, input membership function to rules, rules to a set of output characteristics, output characteristics to output membership functions, and the output membership function to a single-valued output or a decision associated with the output. In a conventional fuzzy inference system, an expert who is familiar with the target system to be modeled determines the number of rules. In cases where there are no experts available, the number of membership functions assigned to each input is chosen empirically. Also, the fuzzy inference system is applied to modeling systems whose rule structure is essentially predetermined by the user's interpretation of the characteristics of the variables in the model. Here, the shape of the membership functions depends on parameters, and changing these parameters will change the shape of the MF. Instead of just looking at the data to choose the MF parameters, MF parameters can be chosen automatically using ANFIS [4]. Hybrid learning algorithm is used in ANFIS to train the network parameters. It combines the gradient method and the least square estimate to identify the MF parameters. Though we can apply the gradient method to identify the parameters in an adaptive network, the method is generally slow and is likely to become trapped in local minima. Hence, we use hybrid rule which decreases the dimension of the search space in the gradient method and also cuts down substantially the convergence time. Since the ANFIS architecture is a multilayer network, gradient method learning rule is used to tune the parameters in the hidden layer and the parameters in the output layer can be identified by the least squares method. The hybrid learning rule detail is given in [5].

**3.3. ANFIS Architecture: Sugeno's ANFIS.** The general architecture of ANFIS [6] is shown in Figure 3. It has two inputs  $x$  and  $y$  and one output  $z$ . Assume the rule base contains two fuzzy if-then rules of Takagi and Sugeno's type.

Rule1: If  $x$  is  $A_1$  and  $y$  is  $B_1$ , then  $f_1 = p_1x + q_1y + r_1$ .  
 Rule2: If  $x$  is  $A_2$  and  $y$  is  $B_2$ , then  $f_2 = p_2x + q_2y + r_2$ .

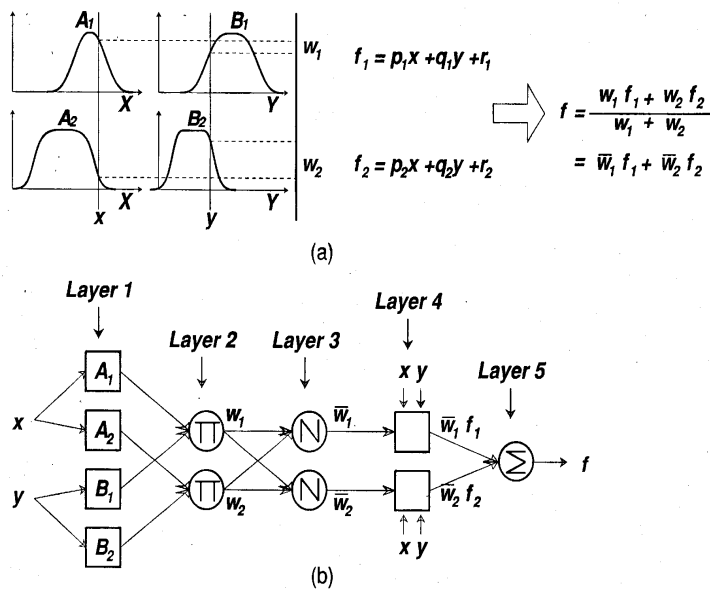

FIGURE 3. (a) A two input first order Sugeno fuzzy model with two rules, (b) Equivalent ANFIS architecture.

Architecture consists of 5 layers excluding inputs and output. The node functions in the same layer are of the same function family as described below.

*Layer 1:* Every node  $i$  in this layer is an adaptive node with a node function

$$O_{1,i} = \mu_{A_i}(x), \text{ for } i=1, 2 \text{ or } O_{1,i} = \mu_{B_{i-2}}(y), \text{ for } i=3, 4 \quad (3)$$

Where  $x$  is the input to node  $i$ , and  $A_i$  is the linguistic label associated with this node function. Parameters in this layer are called premise parameters.

*Layer 2:* Every node in this layer is a fixed node labeled  $\Pi$ , whose output is the product of all the incoming signals:

$$O_{2,i} = w_i = \mu_{A_i}(x)\mu_{B_i}(y), i = 1,2 \quad (4)$$

Each node output represents the firing strength of a rule.

*Layer 3:* Each node in this layer is a fixed node labeled  $N$ . The  $i$ -th node calculates the ratio of the  $i$ -th rule's firing strength to the sum of all rules' firing strength:

$$O_{3,i} = \bar{w}_i = \frac{w_i}{w_1 + w_2}, i = 1,2 \quad (5)$$

Outputs of this layer are called normalized firing strengths.

*Layer 4:* Every node  $i$  in this layer is an adaptive node with a node function

$$O_{4,i} = \bar{w}_i f_i = \bar{w}_i (p_i x + q_i y + r_i), \quad (6)$$

where  $\bar{w}_i$  is a normalized firing strength from layer 3 and  $\{p_i, q_i, r_i\}$  is the parameter set of this node. Parameters in this layer are called consequent parameters.

*Layer 5:* The single node node in this layer is a fixed node labeled, which computes the overall output as the summation of all incoming signals:

$$Overalloutput = O_{5,1} = \sum \bar{w}_i f_i = \frac{\sum w_i f_i}{\sum_i w_i} \quad (7)$$

The structure of this adaptive network is not unique. We can combine layers 3 and 4 to obtain an equivalent network with only four layers.

**3.5. Computations in ANFIS.** The basic steps used in the computation of ANFIS are given below.

- Generate an initial Sugeno-type FIS system using the matlab command *genfis 1*. It will go over the data in a crude way and find a good starting system.
- Give the parameters like number of epochs, tolerance error, number of MF, type of MF for learning.
- Start leaning process using the command *anfis* and stop when goal is achieved or the epoch is completed. Anfis applies the least squares method and the back



propagation gradient descent for identifying linear and nonlinear parameters respectively.

- The *evalfis* command is used to determine the output of the FIS system for given input.

In this paper, we have taken the MEEG as the reference signal and the abdominal signal as the desired signal. These two signals act as training pair for ANFIS training.

#### 4. Results

In order to extract the FECG by ANFIS technique, we have taken real ECG signals contributed by Lieven De Lathauwer [8]. The signals were recorded at a sampling frequency of 500 Hz over 5 seconds from 8 electrodes located on a pregnant woman's skin. The real cutaneous electrode recordings over 2 seconds (1000samples) are plotted in Figure 4 and 5.

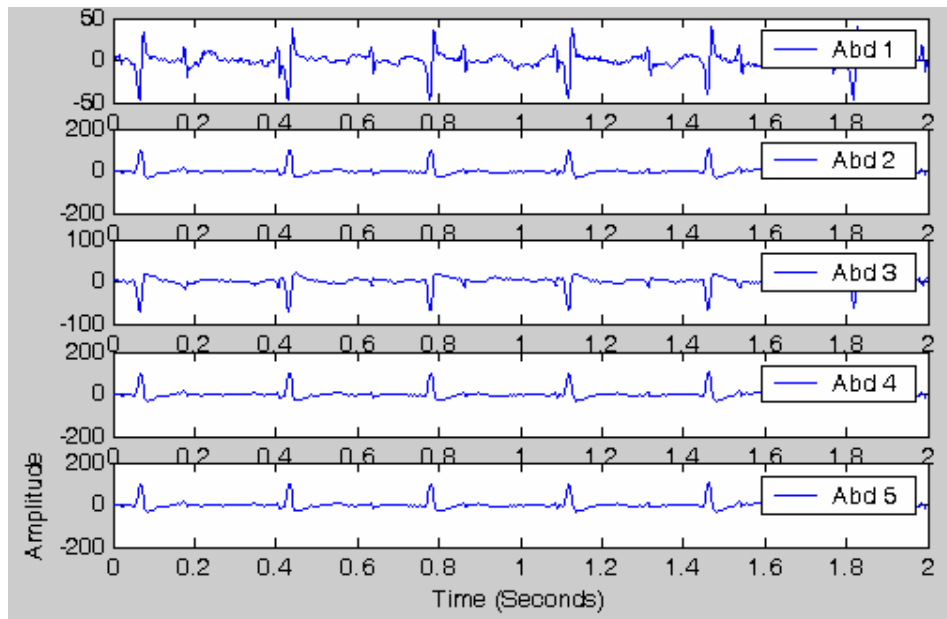

FIGURE 4. Abdominal signals from different electrode positions.

Figure 4 shows the abdominal signals measured in an 8 channel experiment. They have both MEEG and FECG along with some high frequency noise

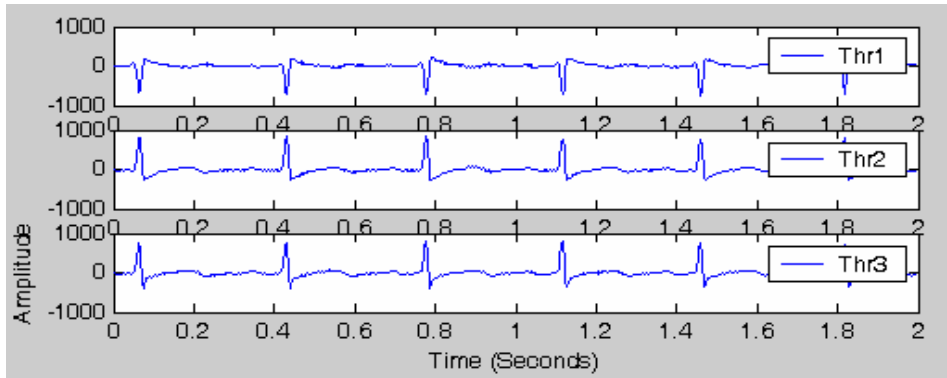

FIGURE 5. MECG signals measured at the thorax region of a pregnant woman.

Figure 5 shows the signals from the mother’s thoracic region (MECG). Due to the longer distance between the thorax electrodes and the fetal heart, no FECG heartbeat component can be perceived in Figure 5. Experiments recently done on the same data using polynomial network are reported in [1]. In order to compare our results with the previous methods, we also use the same signals namely abdominal signal 1 (abd1) and thoracic signal 3 (Thr3) in our analysis. The flowchart for performing MECG cancellation is shown in Figure 6.

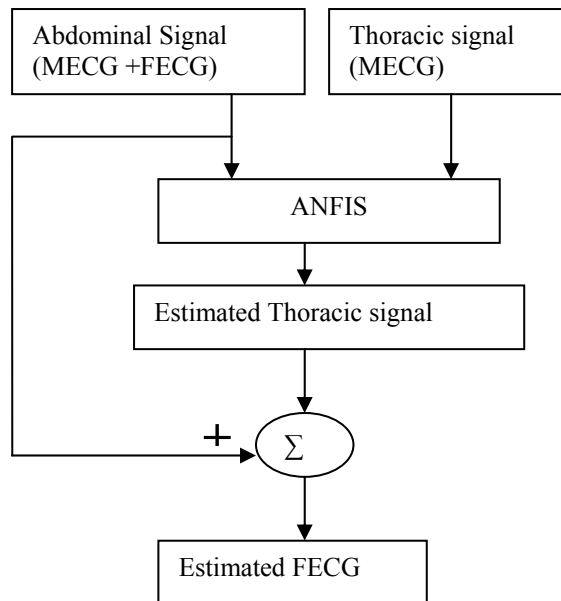

FIGURE 6. Flowchart for the cancellation of MECG and the extraction of FECG.

ANFIS takes the thoracic signal as the reference signal and abdominal signal as the desired signal and tries to estimate the MECG present in the abd1 signal. Once the designated epoch is reached or the goal is reached, it stops training and gives the estimated thoracic signal. Then FECG is extracted by simply subtracting the estimated thoracic signal from the abd1.

In this paper, Matlab version 7.5 is used for software implementation. Since we do not have any idea of what the initial MFs should look like, we can use the command called *genfis1* which will examine the training data set and generate a single-output Sugeno-type FIS that is used as the starting point for ANFIS training. Fuzzy model with 2 inputs and one output generated by this command is shown in Figure 7, where Thr 3 and delayed thr 3 represent the inputs to the fuzzy model. Each input contains 5 MFs. Infismat represents the system name and has 25 fuzzy rules. Estimated MECG represents the system output. Since we are using the Sugeno type, defuzzification is not required at the output.

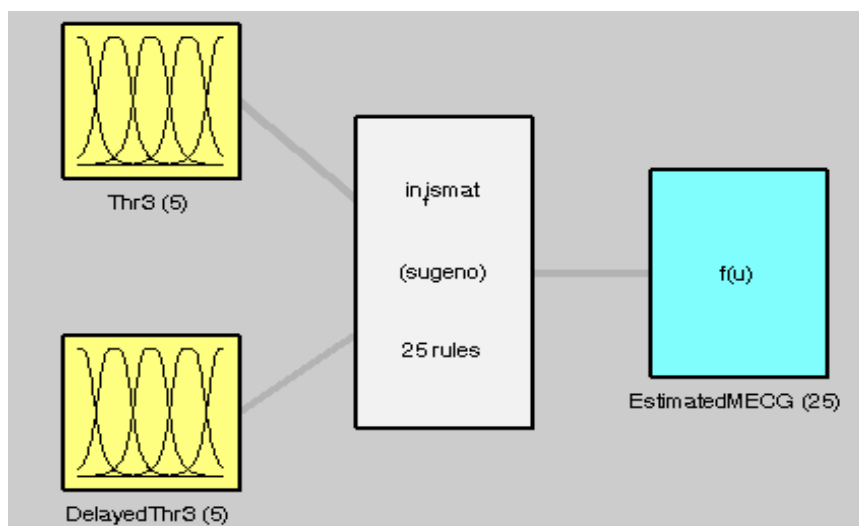

FIGURE 7. Fuzzy model generated by GENFIS.

After generating the fuzzy model, ANFIS requires number of epochs, training pair, and number of MFs for training. The function used for training is *anfis*. In our analysis, generalized bell shape (*gbellmf*) MF is used for ANFIS training. The structure of ANFIS used in the extraction of FECG is shown in Figure 8. Two nodes are present under input layer and represent the inputs. Fuzzification is done by layer 1 (*inputmf*) which allocates 5 MF's to each input. Totally 25 rules are used in. layer 2 (rule). Normalization layer (layer 3) is not included in this architecture. Layer 4 is the defuzzification layer (*outmf*). Layer 5 performs summation operation.

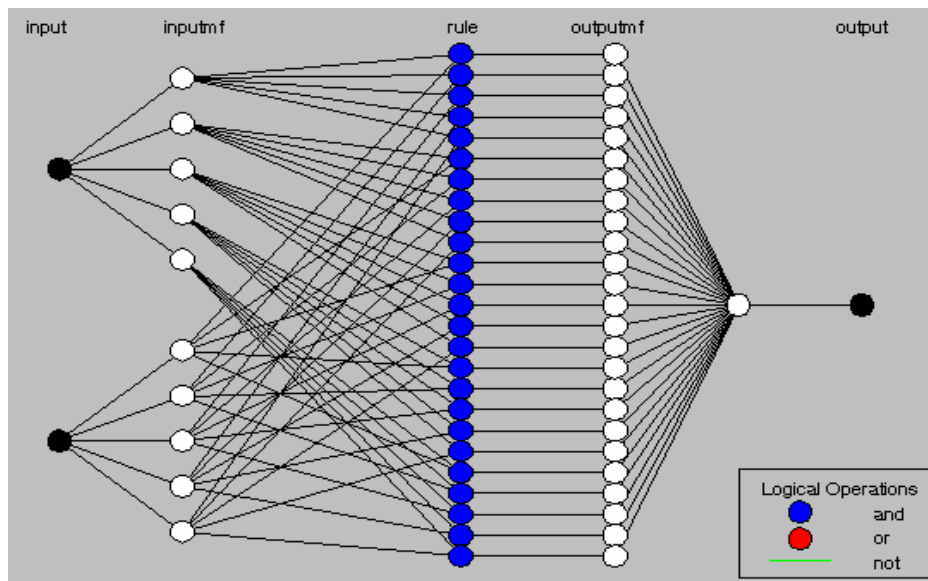

FIGURE 8. ANFIS structure.

During the training process, ANFIS displays the following information:

Number of nodes: 75  
 Number of linear parameters: 75  
 Number of nonlinear parameters: 30  
 Total number of parameters: 105  
 Number of training data pairs: 1000  
 Number of checking data pairs: 0  
 Number of fuzzy rules: 25  
   1 4.18159  
   2 4.18378  
   3 4.17047  
   4 4.15748  
   5 4.16751  
   6 4.15975  
   7 4.17325  
   8 4.15169  
 Step size decreases to 0.720000 after epoch 8.  
   9 4.1564  
 10 4.15797  
 Designated epoch numbers reached -> ANFIS training completed at epoch 10.  
 After training, the estimated MECCG is calculated using the command *evalfis*.

The result obtained through the proposed technique is shown in Figure 9.

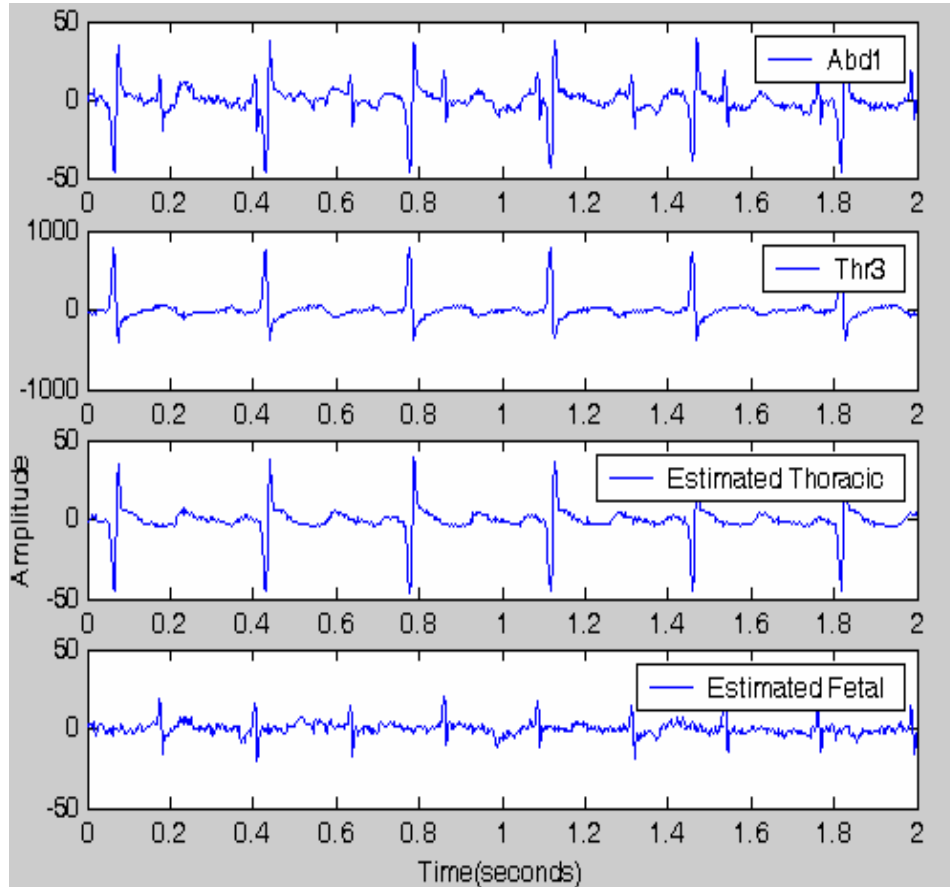

FIGURE 9. FECG extraction using ANFIS.

In Figure 9, for example, at time  $t=0.4$  in *abd1*, we can see that FECG is mixed with MECG. But, estimated fetal displayed in Figure 9 shows that neuro fuzzy technique is capable of extracting the FECG by canceling the MECG. To demonstrate the power of the proposed technique in FECG extraction, we have chosen 3 cases. Figure 10 (a) shows one case containing 3 non overlapping FECG beats and 2 MECG beats. Figure 10 (b) shows the output of ANFIS which is the estimated MECG present in the *abd1* signal. Figure 10 (c) shows the extracted FECG which is free from MECG.

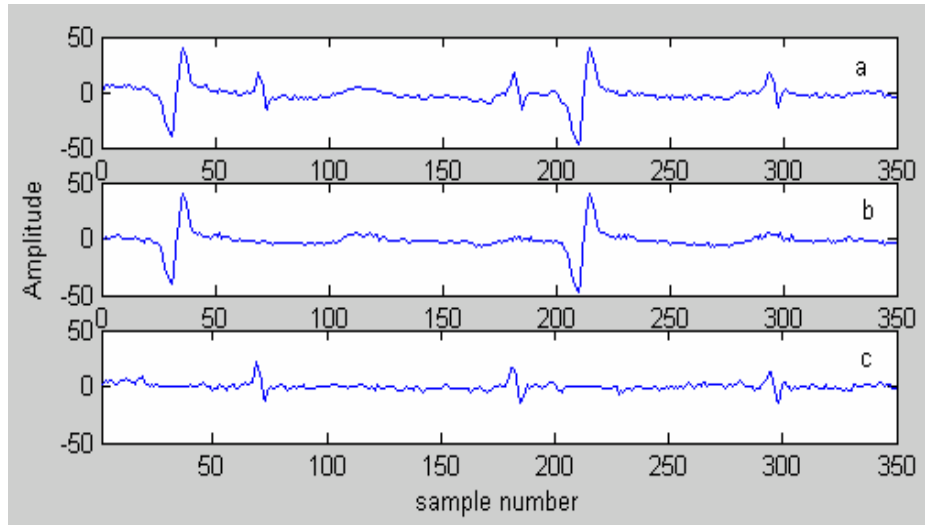

FIGURE 10. (a) Abd1 containing non overlapping three FECG beats and two MECG beats, (b) Estimated MECG (c) the extracted FECG.

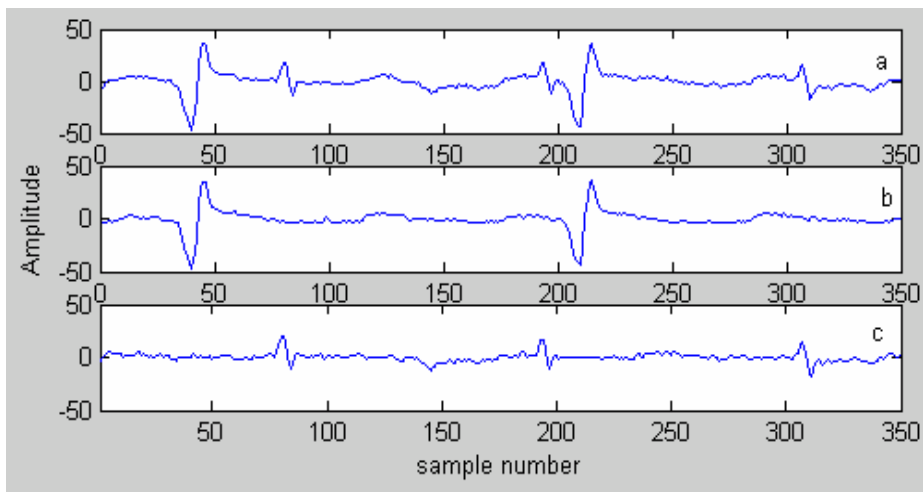

FIGURE 11. (a) Abd1 containing partially overlapping FECG beat and two MECG beats, (b) Estimated MECG (c) the extracted FECG.

Figure 11 (a) shows the second case where abd1 consists of partially overlapping FECG beats and MECG beats. Figure 11(b) and (c) show the separated MECG and FECG components respectively.

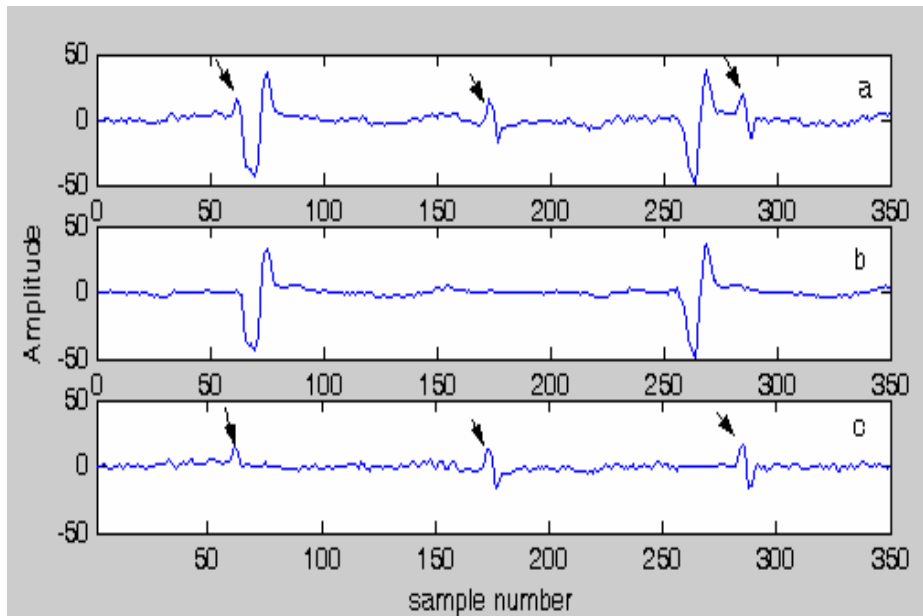

FIGURE 12. (a) Abd1 containing full overlap between the first FECG beat and the MECG, (b) Estimated MECG (c) the extracted FECG signal.

Figure 12 (a) shows the third case containing full overlap between the first FECG and the MECG beats. This represents the extreme case where the FECG is completely dominated by the MECG component to the extent that the FECG beat is no longer visually distinguishable. Figure 12 (c) shows that the proposed technique is successfully capable of extracting the FECG signal. We have divided the 2 second signals into different frames in order to explain the effectiveness of the proposed technique for the extraction of FECG. Practically, if we divide the signals into many frames, then we may lose some important data. It also increases the processing time. But ANFIS can process the entire data without frames which in turn decreases the processing time. In order to find out the signal to noise ratio (SNR) of the estimated FECG signal we have separated the amount of noise present in the estimated FECG using Butterworth filter. To prove that ANFIS yields better result we have given the same inputs and the target to a back propagation network and the results obtained are shown in Figure 13.

In Figure 13 (c), the extracted FECG is still composite and a strong component of the MECG is still apparent in the extracted FECG. By comparing Figure 9 and 13 we can say that noise present in the estimated FECG using ANFIS is less. Performance comparison between neural network and ANFIS in terms of epochs, mean square error (MSE) and SNR is given in Table 1.

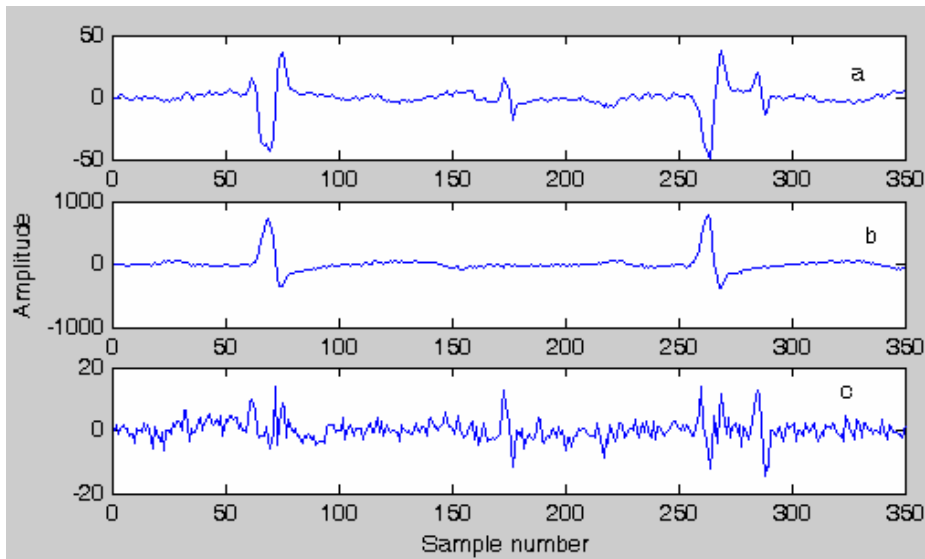

FIGURE 13. FECG extraction using back propagation neural network.

Sl.No	Epochs	Neural Network		ANFIS	
		MSE	SNR	MSE	SNR
1.	10	18.0846	19.9079	18.1889	28.2397
2.	20	14.5482	18.9169	18.1783	28.2991
3.	30	14.8042	18.9111	18.1655	28.3511
4.	40	15.0178	21.4217	18.1512	28.3799
5.	100	14.3927	21.0115	18.0177	28.7174

TABLE 1. Performance comparison between neural network and ANFIS.

In both techniques, step size is assumed as 0.5. From Table 1, we can infer the following:

- a) Neural Network:
  - SNR is less compared to the proposed technique



- Noise present in the estimated FECG signal is more
  - High epoch number is required to get the fine result
  - Convergence time increases when we increase the epochs
- b) ANFIS:
- SNR is high
  - Noise present in the estimated FECG signal is less
  - Less epoch number is sufficient to get the fine result
  - Less convergence time.

If we use only the neural network instead of ANFIS, we cannot diagnose the signal accurately because SNR of its output varies in a random manner. But this is not in the case of ANFIS. As epoch increases, SNR also increases. Table 1 shows that even if we increase the epoch number, its effect on the SNR is negligible in ANFIS. Hence we can use the epoch number 10 as default to train the ANFIS.

Frequency spectrum analysis is used to determine the frequency components present in the MECG and FECG signals. It is helpful to confirm that the estimated FECG signal obtained through the proposed technique is as close as the FECG signal pattern. Doctors are able to diagnose the heart diseases of fetus from the result obtained through ANFIS. Figure 14 shows the frequency component of the MECG and FECG signals.

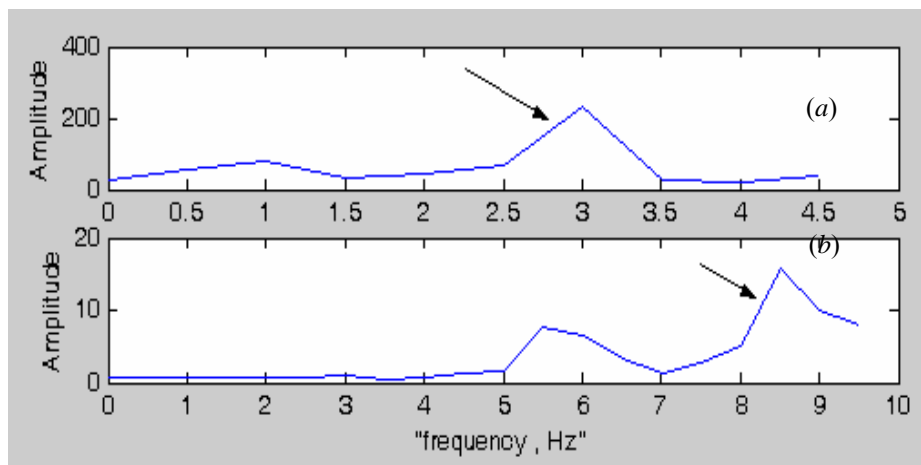

FIGURE 14. Frequency spectrum (a) MECG (b) FECG.

Figure 14 shows that the frequency of FECG signal is higher than that of MECG. The amplitude of FECG is very less compared to that of MECG.

## 5. Conclusion

We have proposed ANFIS technique for the extraction of FECG signals from composite abdominal ECG recordings. The advantage of this technique over other methods is that it requires only one abdominal signal and one thoracic signal. But the other methods require many signals to validate their results. Compared to other methods, ANFIS is well suitable for non linear applications. Mathematical analysis is very less in this method because of the qualitative aspect of the artificial intelligence. Since this technique uses neural network it requires fewer inputs to extract the FECG signal. Convergence time is less compared to methods using neural network alone due to the hybrid rule used in the ANFIS technique. ANFIS can separate the FECG without dividing the signals into different frames. After removing the major interference (MECG) from the FECG, it is easier to cancel the high frequency noise using digital filters. Since the morphology of the extracted FECG using this technique remains same, it can be used by the physician to diagnose.

**Acknowledgments.** The authors are greatly obliged to Dr. D. G. S. Dhinakaran and Dr. Paul Dhinakaran, the chancellor emeritus and the chancellor respectively of Karunya University for providing the research facilities and the necessary finances. Also, thank Dr. Stanley Johnson and prof. K. Rajasekaran for their support.

## REFERENCES

- [1] K. Assalch and H. Al-Nashash, *A novel technique for the extraction of fetal ECG using polynomial networks*, IEEE Transactions in Biomedical Engineering, **52 (6)** (2005), 1148-1152.
- [2] K. Assaleh, *Extraction of fetal electrocardiogram using adaptive neuro-fuzzy inference systems*, IEEE Transactions in Biomedical Engineering, **54(1)** (2007), 59-68.
- [3] M.G. Jafari, and J. A. Chambers, *Fetal electrocardiogram extraction by sequential source separation in the wavelet domain*, IEEE Transactions in Biomedical Engineering, **52( 3)** (2005), 390-400.
- [4] J. S. R. Jang and N. Gulley, *The fuzzy logic toolbox for use with MATLAB*, MA: The MathWorks Inc., 1995.
- [5] J. S. R. Jang, *ANFIS: adaptive-network-based fuzzy inference system*, IEEE Transactions on Systems, Man and Cybernatics, **23(3)** (1993), 665-685.
- [6] J. S. R. Jang, C. T. Sun and E. Mizuatani, *Neuro-fuzzy and soft computing*, Prentice Hall International Inc., 1997.
- [7] A. Khamene and S. Negahdaripour, *A new method for the extraction of fetal ECG from the composite abdominal signal*, IEEE Transactions in Biomedical Engineering, **47(4)** (2000), 507-516.
- [8] L. D. Lathauwer, B. D. Moor and J. Vandewalle, *Fetal electrocardiogram extraction by blind source subspace separation*, IEEE Transactions in Biomedical Engineering, **47(5)** (2000), 567-572.

- [9] M. Martínez, E. Soria, J. Calpe, J. F. Guerrero and J. R. Magdalena GPDS, *Application of the adaptive impulse correlated filter for recovering fetal electrocardiogram*, Computers in Cardiology, Universitat de València. Valencia, Spain, 2001.
- [10] C. Salustri, G. Barbati, and C. Porcaro, *Fetal magnetocardiographic signals extracted by 'signal subspace', blind source separation*, IEEE Transactions in Biomedical Engineering, **52 (6)** (2005), 1140-1142.
- [11] C. K. Selva Vijila, P. Kanagasabapathy and S. Johnson, *Fetal ECG extraction using softcomputing technique*, Journal of Applied Sciences, **6(2)** (2006), 251-256.
- [12] V. Zarzoso and A. K. Nandi, *Noninvasive fetal electrocardiogram extraction: blind separation versus adaptive noise cancellation*, IEEE Transactions in Biomedical Engineering, **48(1)** (2001), 12-18.

C. KEZI SELVA VIJILA\*, DEPARTMENT OF ELECTRONICS AND COMMUNICATION ENGINEERING KARUNYA UNIVERSITY, COIMBATORE, INDIA  
E-mail address: [vijila\\_2000@yahoo.com](mailto:vijila_2000@yahoo.com), [vijila@karunya.edu](mailto:vijila@karunya.edu)

P. KANAGASABAPATHY, DEAN MIT CAMPUS, ANNA UNIVERSITY, CHENNAI, INDIA  
E-mail address: [pks@mail.mitindia.edu](mailto:pks@mail.mitindia.edu)

\* CORRESPONDING AUTHOR