

Approximate Method for Evaluation of the J-Integral for Circumferentially Semi-Elliptical-Cracked Pipes Subjected to Combined Bending and Tension

A. Barani* and G.H. Rahimi¹

In this study, an approximate evaluation method for ductile fracture analysis of a circumferentially semi-elliptical-cracked pipe, subjected to combined bending and tension, was newly developed. This method can explicitly incorporate the contribution of both tension and bending and, also, based on an analytical procedure, put no limit on the crack shape. The effect of a growing crack is neglected and only the J-integral is evaluated. These methods were then verified by full-scale pipe fracture tests. For comparison purposes, a finite element method was employed. The results obtained from the present method are in good agreement with FEM results.

INTRODUCTION

To estimate the structural integrity of pipes, combined loading, consisting of a tensile load due to internal pressure and a bending load, should be considered as a basic loading mode. Aside from ideally brittle materials, any loading of a cracked engineering structure is accompanied by inelastic deformation in the neighborhood of the crack tip, due to stress concentration. Consequently, the ultimate utility of Linear-Elastic Fracture Mechanics (LEFM) must necessarily depend on the extent of inelastic deformation being small compared with the size of the crack and any other characteristic length that cannot be considered for high toughness materials. Theories based on Elastic-Plastic Fracture Mechanics (EPFM) are needed to obtain realistic measures of the fracture behavior of cracked structural systems with these materials.

Elastic-Plastic Fracture Mechanics (EPFM) methods can employ approaches such as elaborate numerical simulations or some approximate analytical evaluation methods. Numerical simulations are generally considered to give reliable predictions for a specific condition. However, approximate evaluation methods seem to be more useful to investigate the

effect of various analytical situations systematically. Based on the J-integral theory, some methods have been proposed to evaluate the ductile fracture behavior of circumferentially through-wall cracked pipes subjected to pure bending. However, there has been inadequate research regarding semi-elliptical cracked pipes with a combined load.

In this study, an approximate evaluation method for ductile fracture analysis of a circumferentially semi-elliptical cracked pipe, subjected to combined bending and tension, is newly developed. This method is intended to incorporate the contributions of both tension and bending.

For circumferentially surface-cracked pipes, perhaps the GE/EPRI method [1] is considered to be the first J-estimation method developed to predict J-integral and other fracture parameters. In this method, Kumar and German [1] compiled a series of FEM solutions for several crack sizes, pipe geometries and material properties in a handbook form. [2]. Rahman and Foxen [3] have presented more reliable solutions using elaborate three-dimensional finite element calculations under constant internal pressure conditions. The Paris.Tada method [4], LBB.NRC method [5], LBB.GE method [6] and LBB.ENG2 method [6,7] are other approximate evaluation methods, which may have a potential to evaluate ductile fracture under combined loading. Rahman and Brust have developed two other new approximate methods to evaluate the J-integral, named SC.ENG1 and SC.ENG2. However,

*. Corresponding Author, Department of Mechanical Engineering, Tarbiat Modares University, Tehran, I.R. Iran.

1. Department of Mechanical Engineering, Tarbiat Modares University, Tehran, I.R. Iran.

Archive of SID

assessment models have been employed to investigate the LBB of cracked pipes that are not for combined load [8]. Yun-Jae Kim et al. [9-11] recently proposed an engineering J estimation method for a semi-elliptical circumferential surface cracked cylinder subjected to pure pressure and pure bending, based on the reference stress concept.

However, these methods were originally developed to apply to pure bending or pure tension. They are often applied to combined loading by substituting an internal pressure for an equivalent bending by some means and, also, are based on experimental results that cannot be used for other crack shapes. Attempts to evaluate the J -integral under combined loading by adding the J -integral due to pure tension and that due to pure bending were also seen in some instances, which have, naturally, no theoretical base, since the principle of superposition cannot be used in the nonlinear region.

In this study, an attempt has been made to evaluate the J -integral under combined loading, which considers tension and bending simultaneously and, also, based on an analytical procedure, puts no limit on the crack shape.

Evaluation of the Moment-Rotation Relationship

Consider a circumferentially semi-elliptical cracked pipe subjected to a combined bending and tension, due to internal pressure, shown in Figure 1. Assume that the total moment rotation, φ , may be written, as follows:

$$\varphi = \varphi_c + \varphi_{nc}, \quad (1)$$

φ_c may be separated into its elastic and plastic components:

$$\varphi_c = \varphi_{el} + \varphi_{pl}. \quad (2)$$

The φ_{el} and φ_{pl} under combined loading are evaluated as the following procedures.

Evaluation of φ_{el}

The elastic energy release rate, J_e , at the point of maximum depth, can be defined, as follows:

$$J_e = \frac{\partial U_T}{\partial A} = \frac{\partial}{\partial A}(U_c + U_{nc}) = \frac{\partial U_c}{\partial A}, \quad (3)$$

where U_T is the total internal strain energy, U_{nc} is the strain energy which would exist if there were no crack, U_c is the additional strain energy in the pipe due to the presence of a crack and $A = \frac{a_0 \pi (R_m - t/2) \theta}{2} = \frac{2}{3} \theta a_0^2$ is the cracked area that can be obtained regarding Figure 2. R_m is defined in Figure 3. For a thin-walled pipe with a mode-I crack growth, J_e , at the point of maximum depth, can be obtained, as follows:

$$J_e = \frac{(K_{IB} + K_{IT})^2}{E'}, \quad (4)$$

where K_{IB} and K_{IT} are bending and tensile stress intensity factors, respectively and $E' = E/(1 - \nu^2)$, for a plane strain condition, with E and ν representing elastic modulus and Poisson's ratio of the material, respectively.

From the LEFM theory, K_{IB} and K_{IT} , at the deepest point of the crack, are given by [12]:

$$K_{IB} = \sigma_b \sqrt{\pi a} F_B, \quad \sigma_b = \frac{M}{\pi R_m^2 t}, \quad (5)$$

$$F_B = 1.1 + \frac{a}{t} \left[0.09967 + 5.0057 \left(\frac{a}{t} \cdot \frac{\theta}{\pi} \right)^{0.565} + 2.8329 \left(\frac{a}{t} \cdot \frac{\theta}{\pi} \right) \right],$$

$$K_{IT} = \sigma_T \sqrt{\pi a} F_T, \quad \sigma_T = \frac{T}{2\pi R_m t},$$

$$F_T = 1.1 + \frac{a}{t} \left(0.15241 + 16.772 \left(\frac{a}{t} \cdot \frac{\theta}{\pi} \right)^{0.855} + 14.944 \left(\frac{a}{t} \cdot \frac{\theta}{\pi} \right) \right), \quad (6)$$

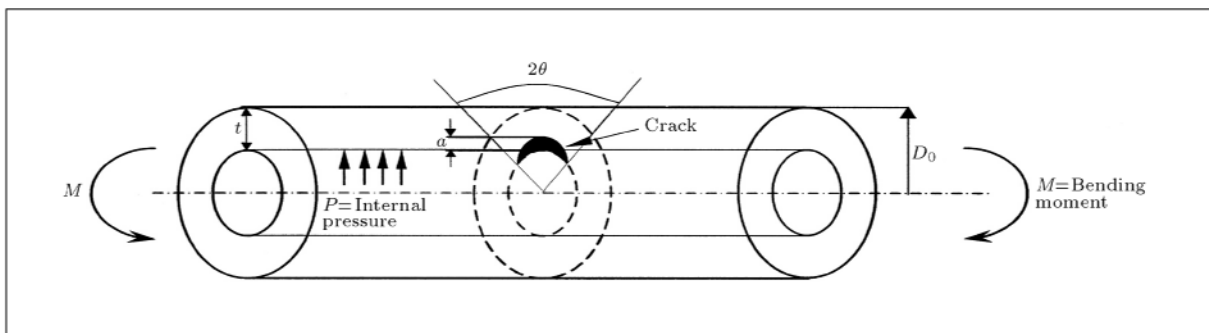

Figure 1. Circumferentially surface-cracked pipe under pressure and bending load.

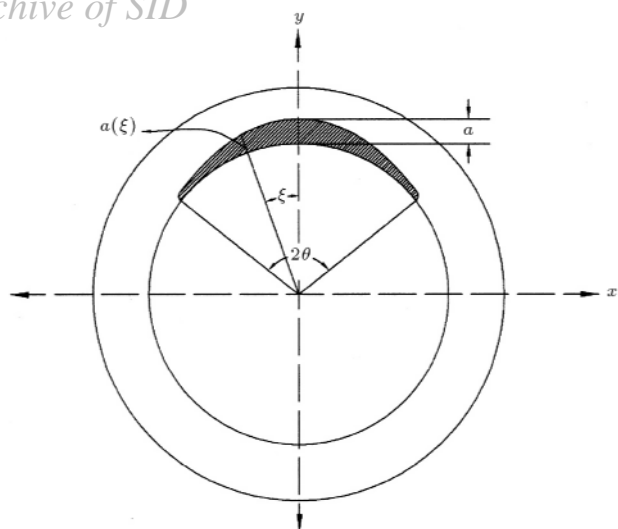

Figure 2. Circumferential semi-elliptical crack $a(\xi) = a\sqrt{1 - (\xi/\theta)^2}$.

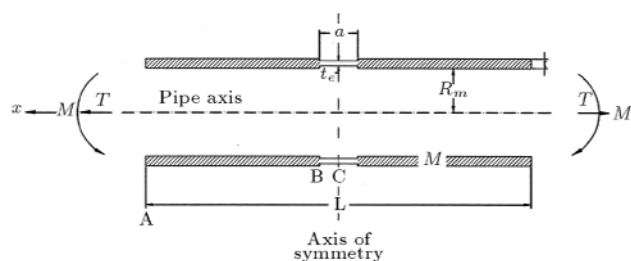

Figure 3. Pipe geometry with equivalent reduced thickness.

φ_{el} is related to the strain energy due to crack, U_c , using Castigliano's theorem:

$$\varphi_{el} = \frac{\partial U_c}{\partial M}. \tag{7}$$

While U_c may be written, as follows:

$$U_c = \int_0^A \frac{(K_{IB} + K_{IT})^2}{E'} dA,$$

or:

$$U_c = \int_0^a \frac{(K_{IB} + K_{IT})^2}{E'} \cdot \frac{dA}{da} da. \tag{8}$$

By integrating the above equation:

$$\varphi_{el} = \frac{1}{E' \pi R_m^3 t^2} \left[\frac{2M}{R_m} I_B(a/t, \theta/\pi) + T I_T(a/t, \theta/\pi) \right], \tag{9}$$

where I_B and I_T can be evaluated, using the integral in Equation 8, φ_{el} can be explicitly calculated.

Evaluation of φ_{pl}

As for the evaluation of φ_{pl} , the beam theory can be enforced to the pipe of a nonlinear elastic material under the deformation theory of plasticity. This hypothesis is the same as the supposition used in [13], which considered the compatibility for pure bending, while the present evaluation method attempts to take account of both bending and tension loading, simultaneously.

A widely used constitutive law describing material's stress-strain relation is the well-known Ramberg-Osgood model, given by:

$$\frac{\varepsilon}{\varepsilon_0} = \frac{\sigma}{\sigma_0} + \alpha \left(\frac{\sigma}{\sigma_0} \right)^n, \quad \sigma_0 = E\varepsilon_0, \tag{10}$$

where σ_0 is a reference stress, which can be arbitrary, but, typically, assumed to be the yield stress, $\varepsilon_0 = \sigma_0/E$ is the associated reference strain and α and n are the parameters of the above power-law model, usually chosen from a best fit of experimental data.

The nonlinear part of the equation was considered for the evaluation of φ_{pl} and the elastic part was neglected.

The hypothesis that has been used by Rahman is obvious in Figure 3. In this figure, the cracked part of the pipe is replaced by a pipe section with reduced thickness, t_e , extending for a distance, \hat{a} , at the cracked section. The reduced thickness section is expected to simulate the reduction of the compliance, due to the existence of the crack.

Using the classical beam theory, ordinary differential equations governing the displacement of beams with the Ramberg Osgood constitutive law (plastic part only) can be derived.

$$\begin{aligned} \frac{1}{r} &= \frac{d^2 w}{dx^2} \\ &= \frac{\alpha \varepsilon_0}{R_m} \left(\frac{1}{\hat{k}_M k'_M \hat{k}_P k'_P} \right)^n \cdot \left(\frac{M}{M'_0} \right)^n, \end{aligned} \tag{11}$$

where parameters in this equation are given by the following:

$$k'_M = 1 + \frac{n+1}{n} \cdot \frac{2}{\pi} \beta^2, \quad k'_P = \left[\frac{1}{n} + \frac{2}{\pi} \right] \beta^2, \tag{12}$$

$$\hat{k}_M = \int_0^{\pi/2} (\sin \theta)^{1+1/n} d\theta = \frac{\sqrt{\pi}}{2} \cdot \frac{\frac{1}{2n} + 1}{\frac{1}{2n} + \frac{3}{2}}, \tag{13}$$

$$\hat{k}_P = \int_0^{\pi/2} (\sin \theta)^{1/n} d\theta = \frac{\sqrt{\pi}}{2} \cdot \frac{\frac{1}{2n} + \frac{1}{2}}{\frac{1}{2n} + 1}, \tag{14}$$

Archive of SID

where β is the location of the neutral axis of the pipe, which can be obtained from the equilibrium of horizontal forces along the pipe axis and which is considered small enough that $\sin \beta \approx \beta$.

$$\beta = \frac{T}{4\sigma_0 R_m t \hat{k}_p \left(\frac{1}{n} + \frac{2}{\pi} \right)}. \quad (15)$$

Solving Equation 11 for the pipe in Figure 3, φ_{pl} and φ_{el} can be related with:

$$\frac{\varphi_{pl}}{\varphi_{el}} = \alpha \left(\frac{1}{\hat{k}_M k'_M \hat{k}_p k'_p} \right)^n \cdot \left(\frac{M}{M'_0} \right)^{n-1} \left(\frac{t}{t_e} \right)^{n-1} \left(\frac{4\pi}{\pi^2 - 8} \right), \quad (16)$$

where $M'_0 = 4\sigma_0 R_m^2 t$ is the yield moment for the uncracked pipe.

Evaluation of Equivalent Thickness

The equivalent reduced thickness in Equation 16 may be taken, so that the load of the cracked pipe is identical to that of the reduced thickness section. This is called SC.ENG1, when the load is the net-section-collapse of the pipe, which was used by Rahman for a pure bending condition. In this case, with a combined load, t_e was calculated by the NSC theorem. The following equations are used when $\beta \leq \pi - \theta$:

$$\beta = \pi \left(\frac{1}{2} - \frac{T}{4\sigma_0 R_m \pi t} - \frac{a_0 \theta}{8\pi t} \right), \quad (17)$$

$$\frac{t}{t_e} = \frac{2}{2 \sin \beta - \frac{1}{2t} a_0 \pi J_1(\theta)}, \quad (18)$$

where $J_1(\theta)$ is the Bessel function of the first kind.

However, SC.ENG1 poorly predicted the J-integral and, so, a new load needed to be developed, in order to substitute with a net-section-collapse, in order to obtain more accurate results. The load is that which provides local yielding at the deepest point of the crack tip.

From the force equilibrium, β , the location of the neutral axis can be evaluated, as follows:

$$\beta = \cos^{-1} \left(\frac{a_0 \sin \theta + \frac{T \cos \theta}{2R_m \sigma_0}}{(t\pi - a_0 \theta) \frac{T}{2R_m \sigma_0}} \right). \quad (19)$$

Also, from moment equilibrium, one obtains the following:

$$\begin{aligned} M &= 2R_m^2 \int_0^\theta \sigma_1 (t - a(\xi)) \cos \xi d\xi \\ &+ \int_\theta^\pi 2\sigma_1 R_m^2 t \cos \xi d\xi \\ &+ \int_0^\beta 2\sigma_2 R_m^2 t \cos \xi_1 d\xi_1, \end{aligned} \quad (20)$$

where σ_1 , σ_2 and ξ_1 are illustrated in Figure 4.

$$\sigma_1 = \frac{\sigma_0 (\cos \beta + \cos \xi)}{\cos \beta + \cos \theta}, \quad (21)$$

$$\sigma_2 = \frac{\sigma_0 (\cos \xi_1 - \cos \beta)}{\cos \beta + \cos \theta}. \quad (22)$$

Equation 19 can be solved for a semi-elliptical crack, to obtain:

$$M = R_m (2R_m t \pi \sigma_0 - P) \left(\frac{1}{2} + \left(\frac{P}{2R_m t \pi \sigma_0 - P} \right)^2 \right). \quad (23)$$

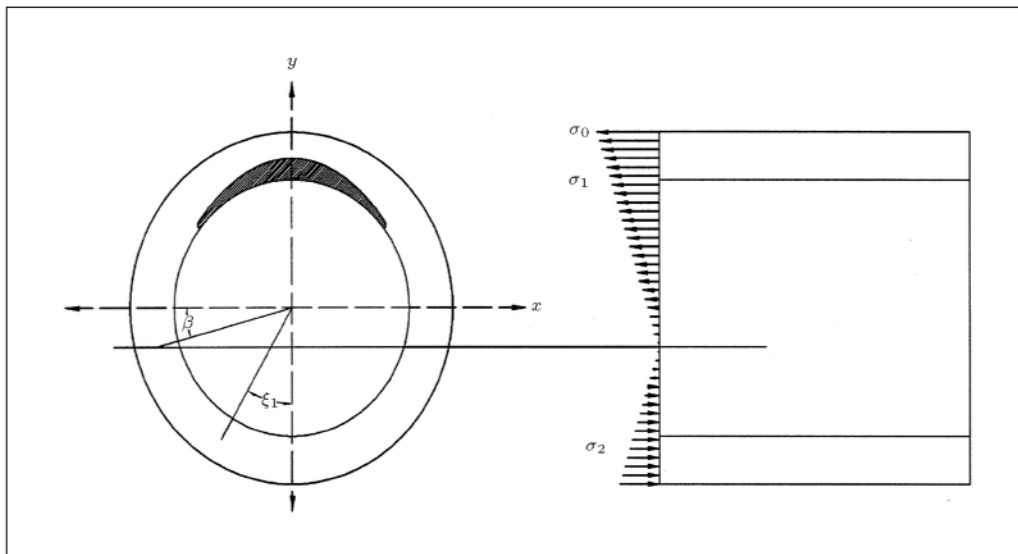

Figure 4. Stress distribution in crack section for presented method.

Archive of SID

And, according to the definition of equivalent thickness, t/t_e would be:

$$\frac{t}{t_e} = \frac{2R_m t \pi \sigma_0}{\frac{2M}{R_m} + P} \quad (24)$$

Evaluation of J-Integral

The plastic energy release rate, J_{pl} , also, at the point of maximum depth, can be defined, as follows:

$$J_{pl} = \frac{\partial}{\partial A} \int_0^M \varphi_{pl} dM + \frac{\partial}{\partial A} \int_0^T \delta_{pl} dT. \quad (25)$$

The δ_{pl} , due to axial load, is considered to be small, so that the second integration of the right side in Equation 24 is negligible.

Having t_e , one can explicitly calculate J_{pl} , as follows:

$$J_{pl} = \frac{\alpha}{E' \pi R_m^3 t^2 \left(\frac{\pi(R_m t/2)\theta}{2} - \frac{4}{3}\theta a_0 \right)} \cdot \frac{\partial}{\partial a} \int_0^M \left(\frac{1}{\hat{k}_M k'_M \hat{k}_P k'_P} \right)^n \cdot \left(\frac{M}{M_0} \right)^{n-1} \left(\frac{t}{t_e} \right)^{n-1} \left(\frac{4\pi}{\pi^2 - 8} \right) \cdot \left(\frac{2M}{R_m} I_B(a/t, \theta/\pi) + T I_T(a/t, \theta/\pi) \right) dM. \quad (26)$$

Finite Element Analysis

An elastic plastic finite-element analysis was used to evaluate the accuracy of the proposed methods. The finite element results were generated by the ABAQUS computer program (ABAQUS, 6.3.1) and using the full-scale three-dimensional solid model.

Because of the symmetry, only one-fourth of the cylinder is considered in the modeling. Figure 5 shows the typical finite element model for the pipe. Two types of three-dimensional element are used in the modeling.

The singular elements are applied along the crack front and the 20-node iso-parametric quadratic brick elements, with reduced integration (C3D20R in ABAQUS), are applied elsewhere. The singular elements along the crack fronts are established by shifting the mid-side nodes to the quarter position, which produce square-root singularities in the stresses and strains along the crack front in Figure 6 [14]. But, the crack tip nodes are untied and allow the crack tip to blunt in the plastic condition. Figure 7 shows the blunted crack tip after loading.

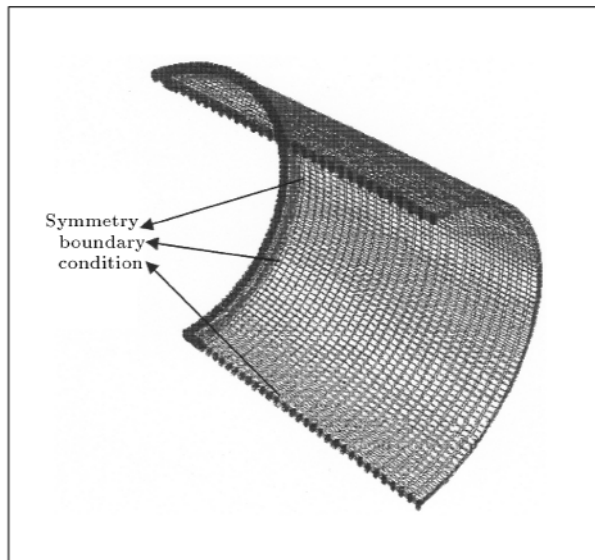

Figure 5. Finite element model of one-fourth of pipe.

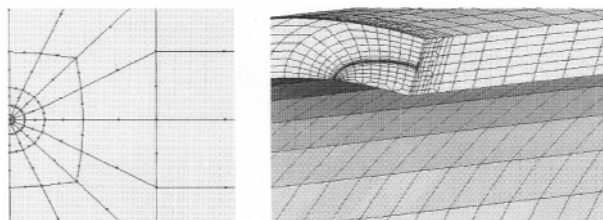

Figure 6. Finite element model and mid-node position along crack front.

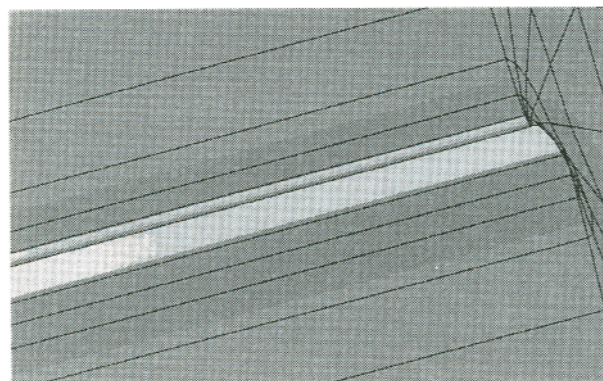

Figure 7. Crack tip after loading.

The FE analyses were performed using deformation plasticity and the small strain analysis theory.

To check the validity of the finite element model of arbitrary points along the crack front, the J values were extracted, not only at the deepest point ($\xi = 0$), but also, at some discrete points along the crack front, including the surface point ($\xi = \theta$). Confidence in the present FE analysis was gained from the path independence of the FE J values, i.e., the J values from eight contours differ within a few percent (Figure 8).

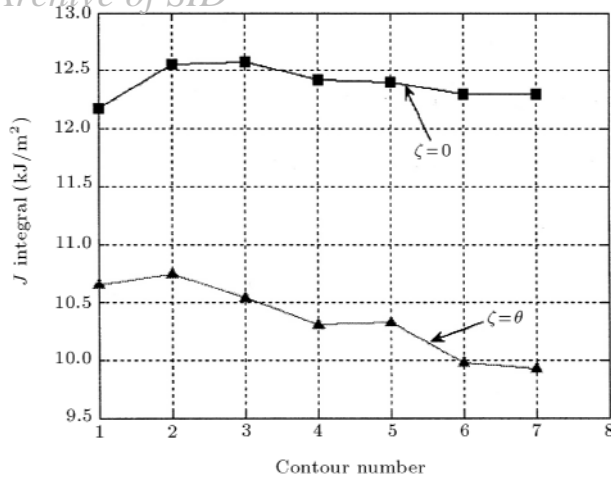

Figure 8. J-integral variation within different contours.

Thus, the FE J-integral was calculated from the mean of the 2nd-7th contours. Further confidence was gained by comparing the FE stress intensity factor solutions with existing ones.

Figure 9 shows the J-integral along the crack front; it can be seen that the J-integral reaches the largest values at the deepest points of the internal surface crack and decreases from the deepest point to the surface point along the crack front. The distribution of the calculated J-integral along the circumferential internal surface crack is as if it were expected.

RESULTS AND DISCUSSION

In this section, the results of the presented method, along with the finite element results, are given for some examples of a cracked pipe tolerating a combined load.

In Figures 10 and 11, the moment and tension are identical quantitatively and the J-integral is plotted versus the applied tension. In these two figures, the applied load is considered, so that the assumption of

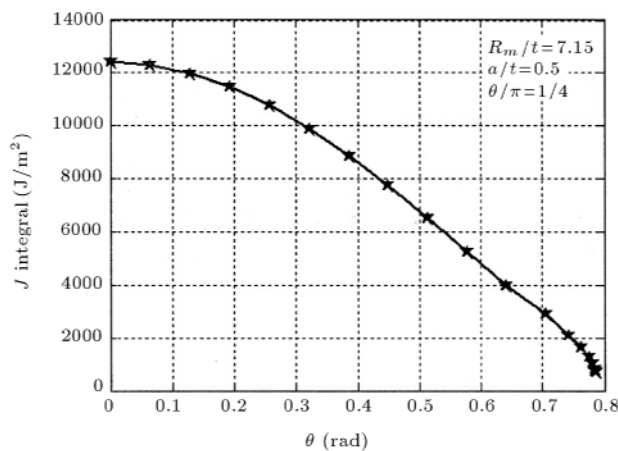

Figure 9. J-integral along the crack front for a pipe with an internal crack.

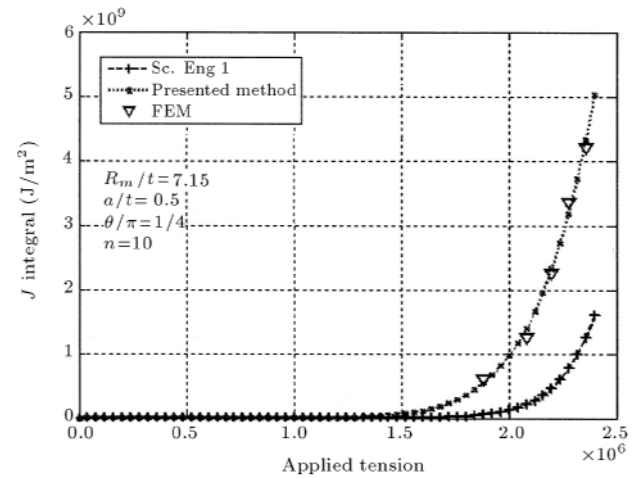

Figure 10. Comparison of J-integral of circumferentially cracked pipe for deepest point by different methods $R_m/t = 7.15$, $n = 10$, $\theta/\pi = 1/4$.

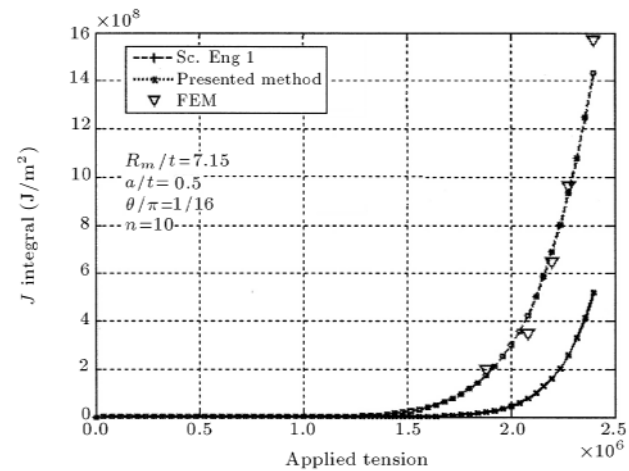

Figure 11. Comparison of J-integral of circumferentially cracked pipe for deepest point by different methods $R_m/t = 7.15$, $n = 10$, $\theta/\pi = 1/16$.

$\sin \beta \approx \beta$ is satisfied. As is obvious in Figures 10 and 11, the presented method results agree with FE analysis well, but, SC.ENG1 cannot predict the J-integral. In another case, the applied load is assumed to be three times greater than the moment, quantitatively, the assumption of $\sin \beta \approx \beta$ will no longer be valid and neither method will predict the J-integral, which is shown in Figure 12.

CONCLUSION

In this study, the approximate evaluation methods of SC.ENG1 and the presented method, for the ductile fracture analysis of a circumferentially semi-elliptical-cracked pipe subjected to combined bending and tension, were developed. The comparison of results from the existing evaluation showed that the method

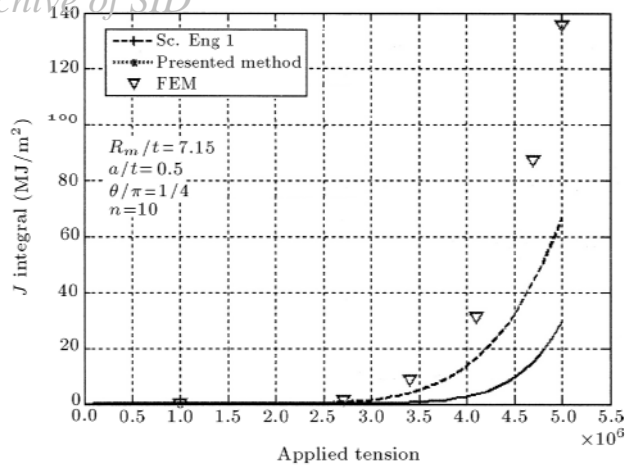

Figure 12. Comparison of J-integral of circumferentially cracked pipe for deepest point by different methods $R_m/t = 7.15$, $n = 10$, $\theta/\pi = 1/4$.

SC.ENG1 was inadequate for practical purposes to analyze the effect of combined loading, while the presented method well predicted the ductile fracture behavior under combined loading. Something that should strongly be considered is that the assumption of $\sin \beta \approx \beta$ is basic when using these methods.

REFERENCES

1. Kumar, V. and German, M.D. "Elastic-plastic fracture analysis of through-wall and surface flaws in cylinders", *EPRINP-5596* (1988)
2. Brust, F.W. et al. "Assessment of short through-wall circumferential cracks in pipes", *Nuclear Regulatory Commission NUREG:CR-6235* (1995).
3. Rahman, S. and Foxen, J. "Effect of pressure on elastic-plastic analysis of small cracks in pipes", *ASME PVP Conf*, **350**, Florida, pp 215-229 (1997).
4. Paris, C. and Tada, H. "The application of fracture proof design method using tearing instability theory to nuclear piping postulating circumferential through wall cracks", *Nuclear Regulatory Commission NUREG:CR-3464* (1983).
5. Klecker, R. et al. "NRC leak-before-break (LBB.NRC) analysis method for circumferentially through-wall cracked pipes under axial plus bending loads", *Nuclear Regulatory Commission NUREG:CR-4572* (1986).
6. Brust, F.W. "Approximate methods for fracture analysis of through-wall cracked pipes", *Nuclear Regulatory Commission NUREG:CR-4853*, (1987).
7. Gilles, P. and Brust, F.W. "Approximate methods for fracture analysis of tubular members subjected to combined tensile and bending loads", *J. Offshore Mech. Arctic Eng.*, **116**, pp 221-227 (1994)
8. Yoo, Y. and Ando, K. "Leak-before-break behavior of statically indeterminate piping system", *Nuclear Engineering and Design*, **224**, pp 253-263 (2003).
9. Kim, Y.L., Kim, J.S., Lee, Y.Z. and Kim, Y.J. "Non-linear fracture mechanics analyses of part circumferential surface cracked pipes", *International Journal of Fracture*, **116**, pp 347-375 (2002).
10. Kim, Y.L., Kim, J.S., Shim, D.J. and Kim, Y.L. "Applicability of reference stress based J estimates to semi-elliptical surface crack problems", *Journal of Strain Analysis for Engineering Design*, **39**(3), pp 245-260 (2004).
11. Kim, Y.L., Kim, J.S., Park, Y.J. and Kim, Y.L. "Elastic-plastic fracture mechanics method for finite internal axial surface cracks in cylinders", *Engineering Fracture Mechanics*, **71**, pp 925-944 (2004).
12. Murakami, Y., *Stress Intensity Factors Handbook*, Oxford, Pergamon Press (1987).
13. Rahman, S. "Approximate methods for predicting J-integral of a circumferentially surface-cracked pipe subjected to bending", *Int. J. of Fracture.*, **85**, pp 111-130 (1997).
14. Anderson, T.L. "Fracture mechanics fundamentals and applications", 2nd Edn., pp 586-589, CRC Press (1995).