

High Gain and Balanced Output Balun–LNA Employing Positive Feedback Technique for Tuner of Digital Televisions

Nima Rahimzadeh¹, Pejman Rezaei^{2*}

^{1,2}Faculty of Electrical and Computer Engineering, Semnan University, Semnan, Iran.

nimarahimzadeh@semnan.ac.ir, prezaei@semnan.ac.ir

*Corresponding author

Received: 2022-02-20, Revised: 2022-06-11, Accepted: 2022-08-22.

Abstract

High gain Balun-low-noise-amplifier (LNA) is proposed for tuner of digital televisions (DTVs). The proposed Balun-LNA is based on CS-CG (common-source-common-gate) structure. To improve the isolation and frequency response, Balun-LNA has cascode transistors before load resistors. Balun-LNA uses current-bleeding circuit to increase transconductance of CS transistor, so that current-bleeding transistor has transconductance of $N-1$ times larger than transconductance of cascode transistor. Thereby, transconductance and current of CS transistor are increased N times, as $N-1$ times of current pass to current-bleeding transistor. Therefore current of CG and CS stages stay identical. Also, Balun-LNA employs a positive feedback to satisfy input impedance matching and CG transistor has higher transconductance. By increasing transconductance of CS and CG transistors, the proposed Balun-LNA achieves to high voltage gain. Accordingly, CG and CS transistors have symmetrical currents and loads at the differential output of the proposed Balun-LNA. Symmetrical loads cause the balanced differential outputs. This proposed Balun-LNA is designed in 90-nm CMOS technology and covers the frequency range of 40 MHz to 1GHz. This Balun-LNA achieves the voltage gain of 22.6 dB, S_{11} of less than -10 dB and the Minimum NF of 5 dB. This Balun-LNA operates at the nominal supply voltage of 2.2V.

Keywords

Balun-LNA, High Gain, Noise Cancelling, Positive Feedback, Symmetrical Loads, Tuner of Digital Televisions.

1. Introduction

In recent years, wideband radio receivers especially digital TV (DTV) receivers drawn high attention because wireless communication devices must support multi features just on a single chip. Nowadays, digital televisions are used in many places and in different utilizations. Companies in which manufacture digital television rival to manufacture digital televisions with better quality in screen and speaker of digital television. In order to develop the performance of digital television in playing pictures, videos and audios, low noise amplifier must be modified. Decreasing the noise of LNA and boosting the gain of it, in addition to linearity, input impedance matching, power consumption and ... are challenges for modifying LNA for tuner of digital televisions.

In digital television, first the electromagnetic waves of digital video broadcasting (DVB) system are received with antenna of digital television and then are transformed to electrical signal and are transferred to tuner of digital television. Tuner of digital television is an implement which is located at the beginning of mainboard of digital television. Tuner of digital television has an IC by name of Tuner IC. Low noise amplifier is the first and most important block of tuner IC of digital television that has an essential effect on performance and quality of digital televisions.

There are several challenges in designing the low noise amplifier for tuner IC of digital televisions. Digital television frequency band ranging from 48 MHz to 860 MHz which is very wide. Tuner IC of digital television should be handle the signals with broadband and should be have good input impedance matching, sufficient gain, high linearity and low NF over the desired frequency bandwidth [1]. In order to endure strong analog/digital interferes in the terrestrial environment and avoid multiple distortions by hundreds of broadcast channels in the cable environment, the LNA should have high third order input referred intercept point (IIP3) and second order input referred intercept point.

Usually the single ended input LNA is preferred. Also for higher SNR the differential LNAs are used because differential signal processing has high common mode rejection ratio, power supply rejection ratio, and low second order distortion. For wideband applications like the tuner of digital television, the passive transformer is very bulky to be integrated on a chip and its insertion loss degrades the NF and the sensitivity. Hence, it is desirable to adopt the S-to-D LNA combining the Balun and LNA functionality (as an active Balun) in to a single integrated circuit [2]-[3]. However, the involved antenna is usually single ended.

In this paper we propose a Balun low-noise-amplifier (Balun-LNA) for tuner IC of digital television, which has

Balun based structure for high third order input intercept point and second order input intercept point (IIP2), high gain, low noise and low power consumption which is one of the most important characteristics of a LNA in wideband receivers specially in tuner of digital televisions. Also, this Balun-LNA can be used in other wideband wireless radio receivers but it is especially designed for digital video broadcasting system and tuner of digital television.

2. Topology of Usual Balun-LNAs and Their Properties

In recent studies, many of wideband Balun circuit topologies with high linearity and low noise performance have been introduced. The technique of noise cancelling is one of the important ways for designing a low noise and high linear Balun-LNA. Fig.1(a) shows the conventional CGCS Balun- LNA which the CG transistor satisfies the input impedance matching and the CS transistor cancels the noise and distortion of CG transistor, because they become common mode signals at the differential output and are rejected at the LNA output in differential signal processing [4]. Although, the conventional CGCS Balun-LNA has not low NF and high gain. Low-power and low-noise Balun-LNAs, where g_m of the CG stage is increased by employing local feedback or reusing the gain of the CS stage, are presented in [4]–[5]. Decreasing the NF of the conventional CGCS Balun-LNA requires that the generated noise of CS transistor to be reduced, because the NF in conventional CGCS Balun-LNA is almost limited by the CS transistor. By increasing the size and transconductance of the CS transistor, its noise will be decreased to a good amount. Although increasing the transconductance of CS transistor has own challenges. As can be seen in Fig.1 (b), the transconductance (g_m) of the CS transistor is N times larger than transconductance (g_m) of CG transistor and the load resistor of CS transistor is N times smaller than load resistor of the CG transistor [5]. This condition leads to imbalance and mismatch in gain and phase of the differential output which increases the second order distortion and makes the noise- cancellation less perfect. So that we must be solve this problem.

In one work in order to solving the problem, a BLIXER circuit with balanced differential signals at the output stage has been presented but the LNA cannot has symmetrical loads without the mixer stage [6]. In [7] A second order distortion cancellation method using feedback was described. In this LNA, a linear feedback from common mode output to the single-ended input, efficiency cancels the second order distortion products in the differential output. A Balun low noise amplifier which has three invertors at its output has been presented in [8]. This LNA has a global shunt feedback resistor for wideband input impedance matching. Also, a shunt capacitor with current bias transistor in the third gain stage enhance the gain and phase imbalances and linearity of differential output. In this structure because the differential output is determined by second and third stage, it can't reach to an acceptable output balance. In [9] a Balun-LNA with balanced loads has been used. In this structure, a modified current-bleeding technique is employed to enable the Balun-LNA to has the same current in differential outputs. In this structure, current

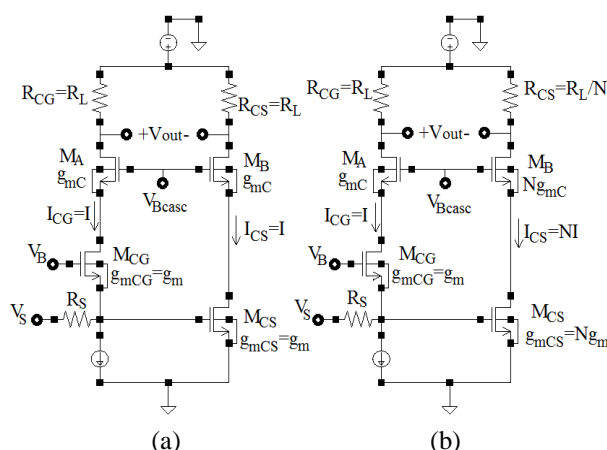

Fig. 1. CGCS Balun-LNA (a) conventional topology with $g_{mCS}=g_{mC}$, $R_{CS}=R_C$ and $I_{CS}=I_C$ (b) practical topology with $g_{mCS}=Ng_{mC}$, $R_{CS}=R_C/N$ and $I_{CS}=NI_C$.

bleeding transistor has transconductance of N-1 times greater than output cascade transistor, which cause that CG transistor has higher transconductance. As a result, the Balun- LNA can has differential outputs with symmetrical loads and without any phase or gain imbalances. In order to decrease the noise factor and power consumption of structure in [9], [10] utilizes a local feedback to decrease the power consumption. In this structure a current bleeding circuit has been used and in addition a negative feedback has been used from output of current bleeding transistor to the input of Balun-LNA (base of CG transistor). In [11] a new current-bleeding circuit has been presented that consist of PMOS transistors instead of NMOS transistors. In this structure modified current bleeding circuit has been utilized to let the Balun-LNA have a differential output with symmetrical loads. But this modified current bleeding circuit increases power consumption. To reduce the power consumption, a local negative feedback has been used to boost the transconductance of CG transistor and current of CG transistor decreased by the same factor and accordingly power consumption of Balun-LNA reduced. But in this LNA the voltage gain is not high enough. Another local feedback is also used in [12] between the CG and CS stage to boost the transconductance of the CG transistor and lower the power consumption, but these structure still has the gain and phase mismatches in differential outputs for having non-symmetrical load resistors. In [13]-[15] another active LNAs have been introduced but none of them has high voltage gain, low NF and enough linearity for tuner of digital televisions. In this paper we proposed a Balun-LNA we used both current-bleeding circuit and positive feedback to increase transconductance of CS and CG transistors for having symmetrical loads at differential output and high voltage gain, low NF and especially symmetrical loads. With using both Current-bleeding circuit and positive feedback, we can have symmetrical current in CG and CS transistor and therefore we can have symmetrical loads at differential outputs without any imbalancing at differential outputs. The rest of the paper is organized as follows. The proposed Balun-LNA is introduced and analyzed in Section 3. Section 4 describes the circuit design and simulation results. Finally, section 5 provides the conclusion.

3. The Structure of Proposed Balun-LNA

This section we introduce the proposed noise-cancelling technique which employs positive feedback and modified current bleeding technique and symmetrical loads together with a detailed analysis.

In this condition, we explain how the transconductance of the both CG and CS transistors can be high enough, in the meantime, to boost voltage gain and reduce the NF and power consumption, and satisfy linearity. As the result, in this proposed Balun-LNA differential outputs with symmetrical resistor loads and identical current would be achievable.

3.1 New Balun-LNA Configurations

The schematic of the proposed Balun-LNA is depicted in Fig.2. The proposed Balun-LNA is basically based on the conventional CGCS Balun-LNA. The purpose of this structure is having high gain, low noise factor, low power consumption and symmetrical loads using modified current-bleeding technique and a positive feedback which controls CG and CS transistor's current.

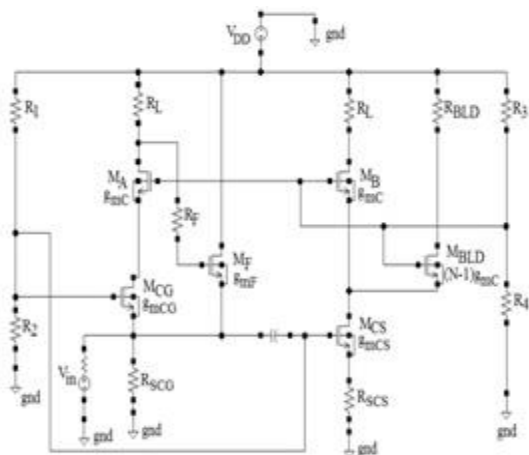

Fig 2. Schematic of proposed Balun-LNA

Controlling the current of CG and CS transistors to have an identical current in CG and CS and their load resistors is a very important challenge. We do this work to have identical current in CG and CS transistors in order to have gain and phase balance in differential outputs. Designing a Balun-LNA in which the transconductance of the both CG and CS stages are the same is very challenging because on the one hand, for having low NF, the transconductance of the CS transistor should be high as mentioned in Section 2, and on the other hand the transconductance of the CG transistor is limited because of the input impedance matching condition. For overcoming this challenges and satisfying this condition, we employed a positive feedback (M_F) to compensate the input matching which allows the CG transistor to has a larger transconductanc. By employing this positive feedback, as it will be say in the next section, we boosted the transconductance and current of CG transistor for increasing voltage gain and decreasing the noise factor of Balun-LNA.

We used both modified current-bleeding and positive feedback to have larger transconductance for CS and CG transistor for low NF, high differential voltage gain and symmetrical current in at the differential output loads for gain and phase balance.

In this proposed Balun-LNA as shown in Fig. 2, M_A and M_B are cascade transistors which are located at the behind of load resistors of differential outout. The cascode stage improves the isolation and frequency response by reducing the Miller effect.

The noise of CG transistor is cancelled by CS transistor, thus the transconductance of CS transistor should be increase. Therefore, we used a modified current bleeding circuit for increasing the trnsconductance of CS transistor.

If we increase the transconductance of CS transistor, the current of CS transistor and output stage of CS transistor will be increase. For overcoming this problem, we used a transistor by name of M_{BLD} which has transconductance amount of $(N-1)$ times higher than transconductance of cascode transistor. Thus, if we N times increase the transconductance of CS transistor, the current of CS transistor will be N times increase too. Consequently, current of $(N-1)I$ passes from transistor of M_{BLD} and current of I passes from cascode transistor and output resistor of CS stage. By using the circuit of modified current bleeding, CS and CG output stages have identical current and therefore symmetrical resistors are used at the differential output of the designed Balun-LNA. By symmetrical loads at the differential output, the Balun-LNA has gain and phase balanced output.

M_{CG} and M_{CS} are biased with two resistor R_1 and R_2 . Cascode transistors are biased with two resistors R_3 and R_4 . Modified current-bleeding transistor M_{BLD} is biased with R_3 and R_4 too.

3.2 Input Impedance Matching

We can have the input impedance matching as:

$$R_S = \frac{1}{g_{mCG} - g_{mF}(g_{mCG}R_L - 1)} \quad (1)$$

Where R_S is the source impedance, g_{mCG} and g_{mF} are the transconductance of the CG and positive feedback (M_F) transistors, respectively.

For achieving this relation, we calculated input admittance by using transconductance of CG and positive feedback transistor. Furthermore, R_L is the symmetrical load resistor. According to (1) we can obtain that, adding the positive feedback transistor, adds very good degree of freedom to the input matching which allows the CG transistor to has higher transconductance for improving NF, differential voltage gain and power consumption of the proposed Balun-LNA. By this work, we increased transconductance of CG transistor and therefore we increased output current of CG stage. But it will be noticed that in this proposed Balun-LNA we designed identical current for CG and CS stages, that it is explained in section 5.

3.3 Differential Voltage Gain

As shown in Fig.2, regardless of considering r_{ds} resistors, we can obtain differential voltage gain as:

$$A_V = g_{mCG} \left(1 + \frac{1}{g_{mF}} \right) R_L \quad (2)$$

Where g_{mCG} is the transconductance of the CG transistors, R_L is the load resistor, and g_{mF} is the transconductance of positive feedback transistor. From (2) we can know that increasing in transconductance of feedback transistor decreases the differential voltage gain and increasing in transconductance of CG transistor increases the differential voltage gain. It seems that we have an important tradeoff between transconductance of CG transistor and positive feedback transistor and therefore we have tradeoff between differential voltage gain and noise factor.

3.4 Noise Analysis

All noise sources are assumed to be uncorrelated. The noise generated by the CG transistor can be cancelled by CS transistor at the differential outputs. The noise generated by cascode transistors is negligible because most of their noise is rotated in their loops and does not appear at the output. Using NF formula, Since the noise contribution of R_{BLD} is very small enough to be negligible, it can be excluded from the noise factor. Therefore, the noise factor of the proposed Balun-LNA is almost limited by the CS and modified current-bleeding and positive feedback transistors, and load resistors and can be expressed as :

$$NF \cong 1 + \frac{\gamma}{g_{mCG} R_S} + \gamma g_{mF} R_S + \frac{\gamma}{g_{mCG} \left(1 + g_{mC} \left(\frac{r_o}{N} \parallel Z_{INBLD} \right) \right)^2} \quad (3)$$

Which Z_{INBLD} is expressed as :

$$Z_{INBLD} \cong \frac{R_{BLD} + r_{oBLD}}{1 + g_{mBLD} r_{oBLD}} = \frac{1}{g_{mCG} - 1} \frac{R_L}{1 + g_{mC}} \quad (4)$$

We combined all NF formulas of CS, modified current-bleeding and positive feedback transistors and load resistors and reached to (3). γ is noise parameter and is equal to 1.8.

4. Simulation Results

This Balun-LNA which employs a positive feedback and modified current-bleeding technique and symmetric loads, was designed and simulated in 90-nm CMOS Technology. This proposed Balun LNA operates in frequency range of 40 MHz to 1 GHz that covers the frequency range of 48 MHz to 864 MHz which is the frequency range of digital television and other wireless receivers. In this proposed Balun-LNA we used voltage supply of 2.2v which is nominal voltage supply of LNAs of digital TV tuner and other wireless receiver's. In this Balun-LNA we considered symmetrical load resistors R_L with amount of 1 K Ω and R_{BLD} with amount of $R_L/4$ (=250 Ω). Larger R_L also provides lower NF, but higher supply voltage is required and the differential voltage gain at high frequencies is degraded. With using this values, the current of R_L of CS and CG stages are identical and equal to $I=4$ mA, because the modified current bleeding circuit has been used, the current of R_L in CS stage is I and identical to the current of R_L in CG stage. By employing this technique, loads of CG and CS stage have

an identical resistance and identical current. This condition causes that, this Balun-LNA has gain and phase balanced differential output. In this conditions transconductance of CS transistor (g_{mCS}) reach to 5 times greater. The amount of transconductance of CS and CG transistors are equal to 20ms. By Using feedback transistor, input impedance matching is satisfied and therefore transconductance of CG transistor can be greater and reach to 20ms. Increasing in transconductance of CS and CG transistors, decreases NF and increases differential voltage gain.

Fig.3 shows the simulated S11 of proposed Balun-LNA. The simulated S11 is much less than -10 dB from 48MHz to 1 GHz. The obtained S11 is one of the best features of this proposed Balun-LNA. Fig.4 shows the differential voltage gain of proposed Balun-LNA. This Balun-LNA has maximum differential voltage gain of 22.68 dB at frequency of 600 MHz. This proposed Balun-LNA has differential voltage gain of higher than 22.6 dB in whole digital television frequency band. Fig.5 shows the NF of this Balun-LNA and Table I represents a comparison between the proposed LNA and some of the previous LNAs.

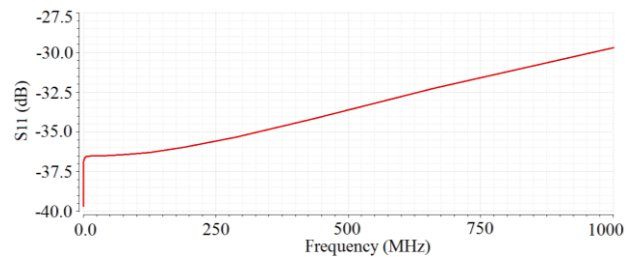

Fig. 3. Simulated S11 of the proposed Balun-LNA.

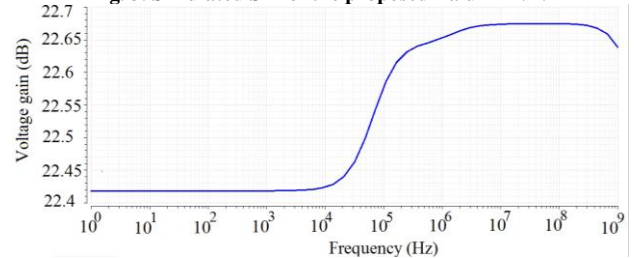

Fig. 4. Simulated voltage gain of Proposed Balun-LNA.

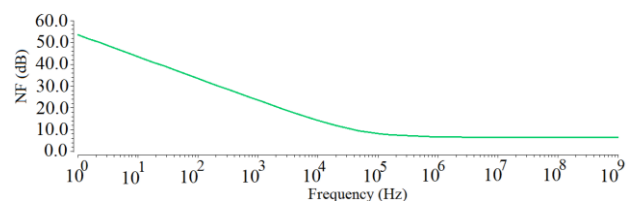

Fig. 5. Simulated NF of proposed Balun-LNA.

As can be seen from Fig. 5 the NF of this proposed Balun-LNA is less than 6 dB from 40 MHz to 1 GHz and the minimum NF of 5 dB is obtained in this proposed Balun-LNA. This proposed Balun-LNA has been designed in 90-nm CMOS technology.

This Balun-LNA consumes power of 8.8 mW at 2.2 v supply voltage, so that this low power consumption is one of the important properties of this proposed Balun-LNA. Table I represents a comparison between this proposed Balun-LNA and some of previous wideband LNAs. According to the table I this proposed Balun-LNA has much higher voltage gain and lower power consumption

than previous structures. But the NF of this proposed Balun-LNA is a little higher than some of previous structures. But this NF is much less than many of low noise amplifiers which can be used in tuner of digital television. The proposed Balun-LNA has excellent S11 which is less than -10 dB and is suitable for tuner of digital television. This proposed Balun-LNA has symmetric loads at the differential outputs. This symmetrical loads at the output causes the gain and phase balance at the output stage of this proposed Balun-LNA and is one of the important achievements of this work. Also, this proposed Balun-LNA has low power consumption compare to other low noise amplifiers which this low power consumption is one of the important achievements of this proposed Balun-LNA. In tuner IC of digital televisions, the low power consumption is one of the important parameters which the designers consider this problem in the designing of low noise amplifiers in order to achieve a tuner IC of digital televisions which consumes less power consumption.

5. Conclusion

A new Balun-LNA for application of tuner of Digital televisions and in 90-nm CMOS technology was proposed in this paper. A new noise cancelling method employing positive feedback and modified current-bleeding (CBLD) circuit and symmetric loads has been used to design a low noise and high differential voltage gain and low power consumption Balun-LNA. Symmetrical loads at differential output cause the gain and phase balanced outputs and modified current-bleeding technique cause a freedom for CS transistor to has higher transconductance. Positive feedback was used because it satisfies input matching and thus CG transistor has higher transconductance. This higher transconductance of CG and CS transistors causes that, the proposed Balun-LNA achieves differential voltage gain of 22.6 dB whole frequency band. The designed Balun-LNA has the NF of less than 6 dB and S11 of less than -10 dB. Power consumption of 8.8 mW in 2.2 v power supply achieves in this proposed Balun-LNA which is low and suitable for tuner of digital televisions.

6. References

[1] D. Im, O. Lee, I. Nam, "A TV Receiver Front-End with Linearized LNA and Current-Summing Harmonic Rejection Mixer", *IEEE Transaction on circuits and Systems-II.*, 2016.

[2] D. Im, I. Nam, and K. Lee, "A CMOS Active Feedback Balun-LNA with High IIP2 for Wideband Digital TV Receivers", *IEEE Transaction on Microwave Theory and Techniques*, vol. 58, no.12, pp.3566-3578, December 2010.

[3] H.-K. Chen, J.-R. Sha, D.-C. Chang, Y.-Z. Juang, and C.-F. Chiu, "5.8-GHz merged LNA-mixer with on-chip balun", *Microwave and Optical Technology Letters*, vol. 48, no. 3, March 2006.

[4] F. Bruccoleri, EA. M. Klumperink, "Wide-Band CMOS Low-Noise Amplifier Exploiting Thermal Noise Canceling", *IEEE Journal of Solid-State Circuits*, vol. 39, no. 2, pp. 275-277, February 2004.

[5] S.C. Blaakmeer, E.A.M. Klumperink, D.M.W. Leenaerts, B. Nautra, "Wideband Balun-LNA with

Simultaneous Output Balancing, Noise-Canceling and Distortion-Canceling", *IEEE Journal of Solid-State Circuits*, vol. 43, no. 6, pp. 1341-1343, 1346-1347, June 2008.

[6] S. Blaakmeer, E. Klumperink, D. Leenaerts, B. Nautra, "A Wideband Balun LNA I/Q-Mixer Combination in 65nm CMOS", (IEEE International Solid-State Circuits Conference, ISSCC) Dig. Tech. Papers, San Francisco, CA, USA pp. 326-328, February 2008.

[7] D. Manstretta, "A Broadband Low-Power Low-Noise Active Balun with Second-Order Distortion Cancellation", *IEEE Journal of Solid-State Circuits*, vol. 47, no. 2, February 2012.

[8] J.Ch. Liu, J.Sh. Chen, "A Wideband Inductorless Single-to-Differential LNA in 0.18 μ m CMOS Technology for Digital TV Receivers", *IEEE Microwave and Wireless Components Letters*, vol. 24, no. 7, July 2014.

[9] S. Kim, K. Kwon, "A 50-MHz-1-ghz 2.3-dB NF Noise-cancelling Balun-LNA Employing a Modified Current-Bleeding Technique and Balanced loads," *IEEE Transactions on Circuits and Systems I: Regular Papers*, vol. 66, no. 2, pp. 546-554, Feb 2019.

[10] S. Kim, K. Kwon, "Broadband Balun-LNA Employing Local Feedback gm-Boosting Technique and Balanced Loads for Low-Power Low-Voltage Applications", *IEEE Transactions on Circuits and Systems I: Regular papers*, vol. 67, no. 12, pp. 4631-4640, Dec 2020.

[11] B. Shirmohammadi, M. Yavari, "A Low Power Wideband Balun-LNA Employing Local Feedback, Modified Current-Bleeding Technique, and Balanced Loads," 2020 28th Iranian Conference on Electrical Engineering (ICEE), Tabriz, Aug. 2020.

[12] J. Kim, J. Silva-Martinez, "Wideband Inductorless Balun-LNA Employing Feedback for Low-Power Low-Voltage Applications.", *IEEE Transaction on Microwave Theory and Techniques*, vol. 60, no. 9, September 2012.

[13] S. Masihi, P. Rezaei, M. Panahi, "Compact chip-resistor loaded active integrated patch antenna for ISM band applications", *Wireless Personal Communications*, vol. 97, no. 4, pp. 5738-5746, August 2017.

[14] A. Valizadeh, P. Rezaei, AA. Orouji, "A New Design of Dual-Port Active Integrated Antenna for 2.4/5.2 GHz WLAN Applications", *Progress In Electromagnetic Research B*, vol. 58, pp. 86-94, January 2014.

[15] A. Valizadeh, P. Rezaei, AA. Orouji, "Design of reconfigurable active integrated microstrip antenna with switchable low-noise amplifier/power amplifier performance for wireless local area network and WiMAX applications", *IET Microwaves, Antennas and Propagations*, vol. 9, no. 9, pp. 874-881, June, 2015.

[16] L. Liu, Zh. Lu, K. Zhang, Zh. Ren, A. Hu, X. Zou, "Wideband balun-LNA exploiting noise cancellation and

g^m compensation technique”, *Electronics Letters*, vol. 52, no. 8, pp. 673-674, April 2016.

[17] J. Chaghaei, A. Jalali, J. Mazloum, “An Inductorless Differential LNA with Active and Passive Enhancement for Cognitive Radio”, *Tabriz Journal of Electrical Engineering*, vol. 50, no. 1, pp. 75-84, spring 2020 (in persian).

[18] A. Bijari, M. Sheikhi, “A 3.1-10.6 Ghz Ultra-Wideband Low Noise Amplifier with Novel Input Matching Network”, *Tabriz Journal of Electrical Engineering*, vol. 49, no. 2, pp. 517-528, summer 2019 (in persian).

[19] S. Jang, S. Park, D. Im, “A PVT Insensitive Noise Canceling Balun-LNA for TV Receiver Application”, *Progress In Electromagnetics Research Symposium-Fall (PIERS-FALL)*, Singapore, pp.1726-1728, 19-22 November, 2017.

[20] P. Donyaran, B. Heidari, “Assessing a Noise Reduction Method for a Low-Noise Amplifier”, *Tabriz Journal of Electrical Engineering (TJEE)*, vol. 51, no. 2, Summer 2021.

[21] J. Kim, S. Hoyos, J. Silva-Martinez, “Wideband Common-Gate CMOS LNA Employing Dual Negative Feedback with Simultaneous Noise, Gain, and Bandwidth Optimization”, *IEEE Transaction on Microwave Theory and Techniques*, vol. 58, no. 9, September 2010.

[22] D. Im, I. Nam, S.S. Song, “A CMOS Resistive Feedback Single to Differential Low Noise Amplifier with Multiple-Tuner-Outputs for a Digital Tv Tuner”, *IEEE Radio Frequency Integrated Circuits symposium*, pp. 555-558, 2009.

[23] D. Mastantuono, D. Manstretta, “A Low-Noise Active Balun with IM2 Cancellation for Multiband Portable DVB-H Receivers”, *University of Pavia, Pavia, Italy, ISSCC*, pp.215-217, 2009.

[24] S. Jin, T.Y. Oh, K.T. Hong, H.T. Kim, B. Kim, “Wide-Band CMOS Loop-Through Amplifier for Cable TV Tuner.”, *IEEE Radio Frequency Integrated Circuits Symposium*, pp. 215-218, 2008.

[25] T. Chang, J. Chen, L.A. Rigge, J. Lin, “ESD-Protected Wideband CMOS LNAs Using Modified Resistive Feedback Techniques with Chip-On-Board Packaging”, *IEEE Transactions on Microwave Theory and Techniques*, vol. 56, no. 8, pp. 1817-1819, August 2008.

[26] R. Eskandari, A. Ebrahimi, H. Faraji, “An area-efficient broadband balun-LNA mixer front-end for multi-standard receivers”, *Tabriz Journal of Electrical Engineering (TJEE)*, vol. 51, no. 1, Spring 2021.

[27] J.V. Sinderen, M. Notten, E. Stikvoort, F. Seneschal, “A 48-860 MHz TV splitter amplifier exhibiting an IIP2 and IIP3 of 94dBmV and 73dBmV”, *Philips Research Laboratories, Eindhoven, The Netherlands, Philips Semiconductors Caen, France, jan.van.*, pp.195-196, 2004.

[28] B.G. Perumana, J.H.C. Zhan, S.S. Taylor, B.R. Carlton, J. Laskar, “Resistive-Feedback CMOS Low-Noise Amplifiers for Multiband Applications”, *IEEE Transactions on Microwave Theory and Techniques*, vol. 56, no. 5, pp. 1218-1219, May 2008.

[29] N. Rahimzadeh, P. Rezaei, “A Balun-LNA Employing Positive Feedback and Modifies Current-Bleeding Technique and Symmetrical Loads for tuner of Digital Televisions,” In 3rd Iranian International Conference on Microelectronics, December 2021, Tehran, Iran (in persian).

[30] N. Rahimzadeh, P. Rezaei, “Decreasing power Consumption of BLNA with Balanced Output with gm Boosting Feedback for Application of Tuner of Digital Televisions,” In 6th Conference Electrical and Computer Engineering Technology, March 2022, Tafresh, Iran (in persian).

Table I. Comparison of proposed Balun-LNA and previous works.

Ref.	CMOS Process	Frequency range (GHz)	S11 (dB)	Voltage gain (dB)	NF (dB)	Symmetric load	Balun function	Power Consumption (mW)	Supply voltage (v)
[2]	180 nm	0.05-0.86	<-8.5	19.5	2.5-3	YES	YES	30	1.2
[4]	250 nm	0.01-1.6	<-8	13.7	1.9-2.4	NO	NO	35	2.5
[5]	65 nm	0.2-5.2	<-10	13-15.6	2.9-3.5	NO	YES	21	1.2
[6]	65 nm	0.5-7	<-10	18	4.5-5.5	NO	YES	16	1.2
[8]	180 nm	DC-1.4	<-10	15-16.4	3-4	NO	YES	12.8	1.5
[9]	65 nm	0.05-1	<-10	24-30	2.2-3.3	YES	YES	19.8	2.2
[10]	65 nm	0.05-1.3	<-10	24-27.5	2.3-3	YES	YES	5.7	1
[12]	130 nm	0.1-2	<-10	13.6-16.6	3.8-5	NO	YES	3	1.2
This Work	90 nm	0.04-1	<-10	22.6	5-6	YES	YES	8.8	2.2