

Using Artificial Neural Networks for Estimation of Springback in Cold Roll Forming

H. Moslemi Naieni; R. Azizi Tafti; M. Tajdari

ABSTRACT

Cold roll forming is a sheet metal forming process in which the bending occurs gradually in several forming steps from an undeformed strip to a finished profile. Although simple appearance, the process is influenced by several parameters that complicate the process design and control such as springback.

The main purpose in this article is to determine a simple criterion for the springback and to introduce a fast solution to obtain it and therefore artificial neural network was proposed for achieving this goal. Cold roll forming of a channel section in the first station was simulated by a commercial package named "Msc Marc Mentat". The data obtained from the finite element simulations were used as training and testing sets for neural networks. Perfect performance of neural network was proved when the neural network outputs were compared with the testing set that did not exist in the training set.

KEYWORDS : Cold roll forming, Springback, Artificial neural networks, Finite element simulation.

// :

// :

.moslemi@modares.ac.ir :

i

.azizitafti@modares.ac.ir :

ii

.tajdari@yahoo.com :

iii

[]

Archive of SID

[]

[]

[]

[]

[]

[]

[]

[]

[]

()

[]



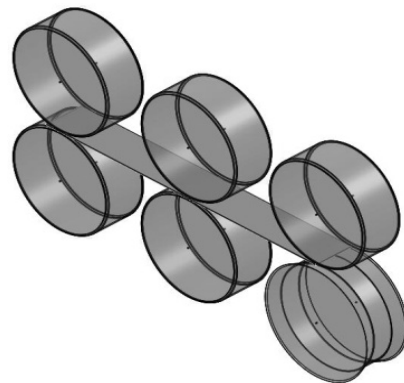

()

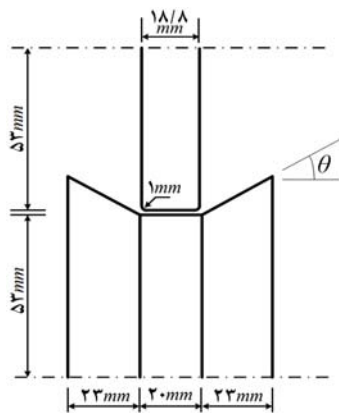

[]

()

1020SAE /

[]

()

()

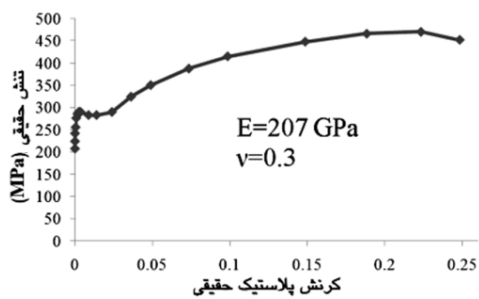

()

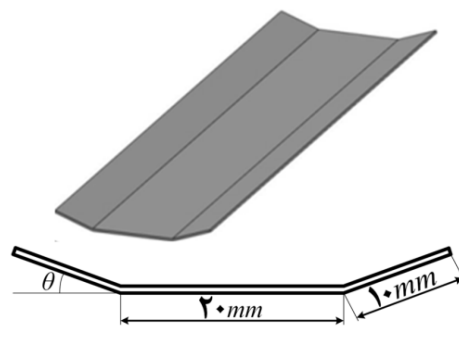

()

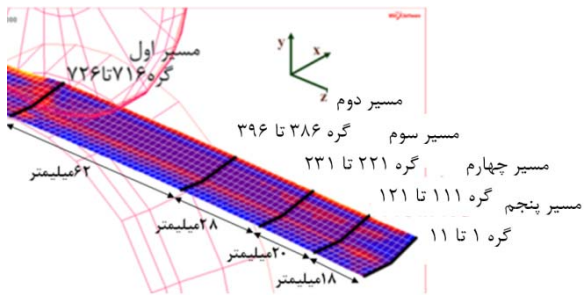

()

o o

x y

dx dy

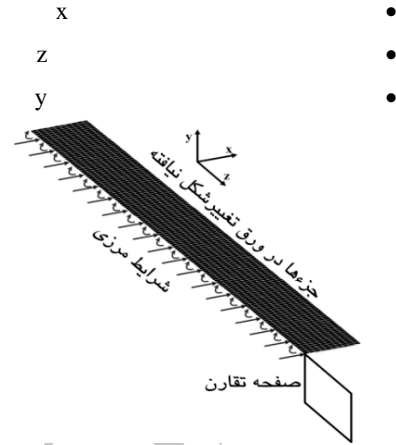

()

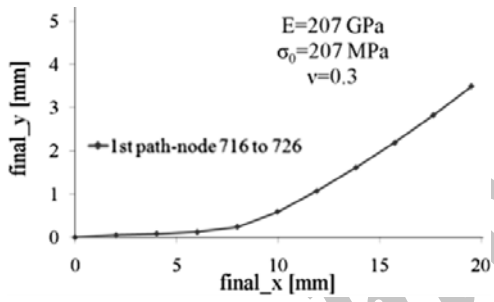

()

()

Archive of SID

[]

()

()

/	/	/	/	o

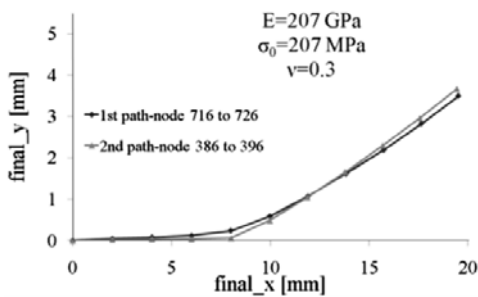

()

()



/ / / /

()

() ()

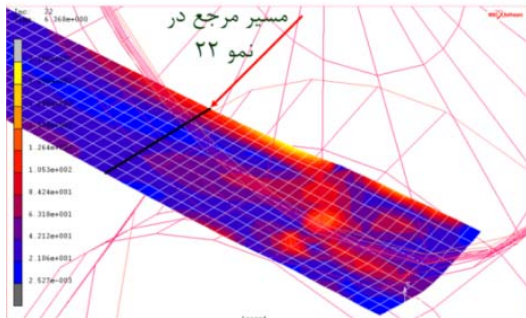

()

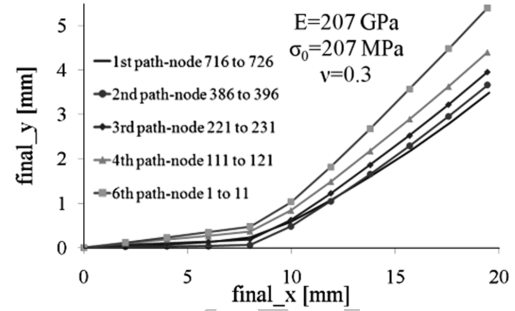

()

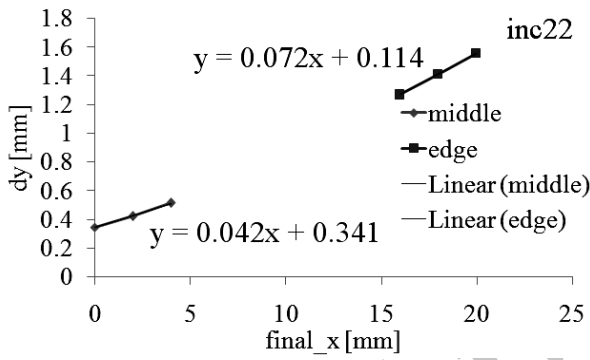

()

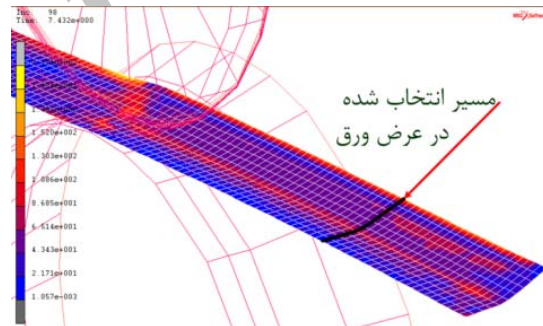

()

y
dy y

()

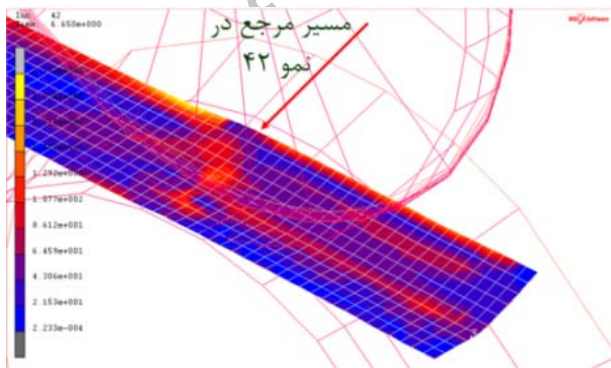

()

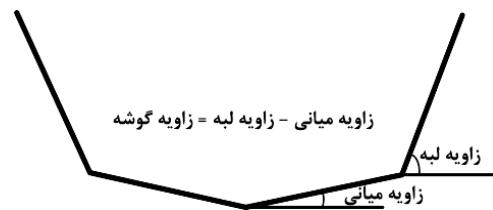

()

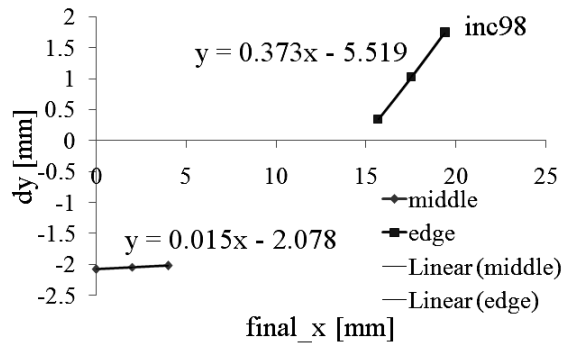
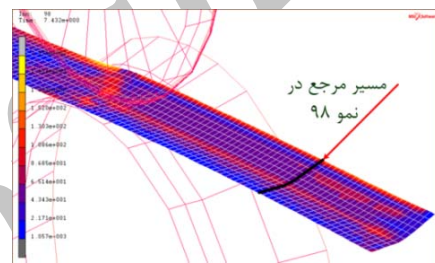
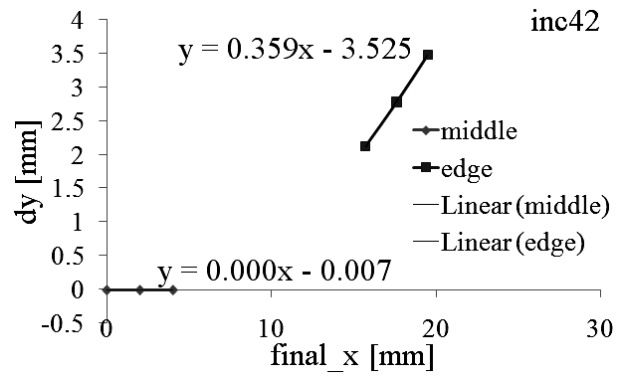
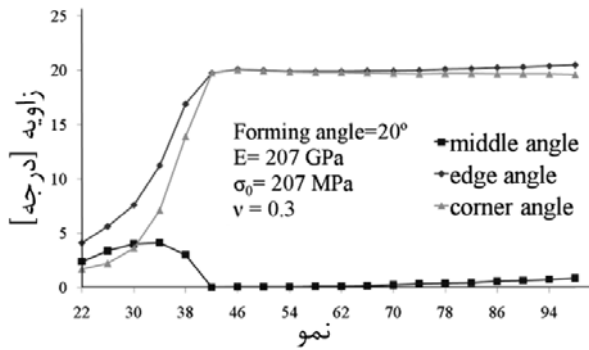

/	/	/	/
/	/	/	/
/	/	/	/
/	/	/	/
/	/	/	/
/	/	/	/
/	/	/	/
/	/	/	/
/	/	/	/
/	/	/	/
/	/	/	/



()

()

()

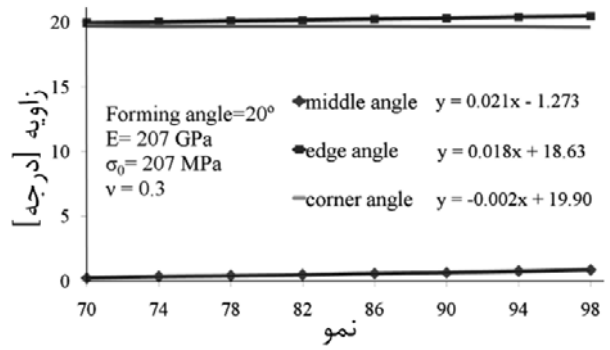

/

()

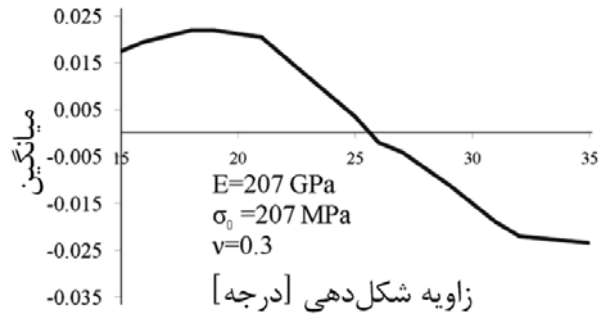

()

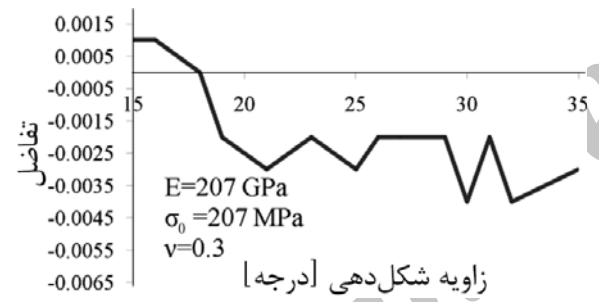

()

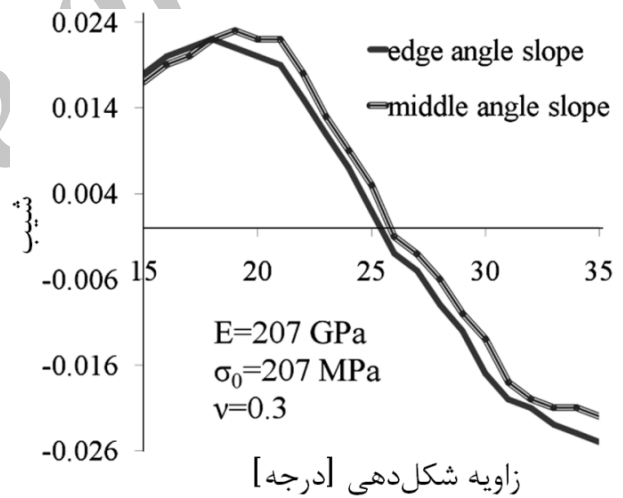

()

()

()

()

:()

/	e	/	e
---	---	---	---



:()

(())

:()

/	e	/	e
---	---	---	---

()

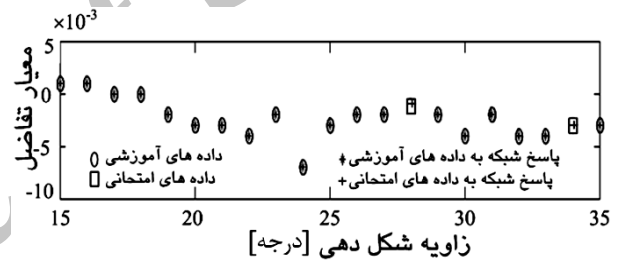

:()

Hong, S.; Lee, S.; Kim, N.; "A parametric study on forming length in roll forming", Journal of Materials Processing Technology, Vol. 113, pp. 774-778, 2001.

Lindgren, M.; "An improved model for the longitudinal peak strain in the flange of a roll formed U-channel developed by FE-analyses", steel research int. 78, No. 1, 2007.

Lindgren, M.; "Cold roll forming of a U-channel made of high strength steel", Journal of Materials Processing Technology, Vol. 186, pp. 77-81, 2007.

Lindgren, M.; "Experimental investigations of the roll load and roll torque when high strength steel is roll formed", Journal of Materials Processing Technology, Vol. 191, pp. 44-47, 2007.

Downes, A., Hartley, P.; "Using an artificial neural network to assist roll design in cold roll-forming processes", Journal of Materials Processing Technology, Vol. 177, pp. 319-322, 2006.

[] Bhattacharyya, D.; Smith, P. D.; "The development of longitudinal strain in cold roll forming and its influence on product straightness", Journal of Advanced technology of plasticity, Vol. 1, 1984. []

[] McClure, C. K.; Hanhui, L.; "Roll forming simulation using finite element analysis", Armstrong world industries, P.O.Box 3511, Lancaster, PA 17604, 1995. []

[] Heislitz, F.; Livatyali, H.; Ahmetoglu, M. A.; Kinzel, G. L.; Altan, T.; "Simulation of roll forming process with the 3D FEM code PAM-STAMP", Journal of Materials Processing Technology, Vol. 59, pp. 59-67, 1996. []

[] Brunet, M.; Lay, B.; Pol, P.; "Computer aided design of roll Forming of channel sections", Journal of Materials Processing Technology, Vol. 60, pp. 209-214, 1996. []

[] Brunet, M.; Mguil, S.; Pol, P.; "Modelling of a roll-forming process with a combined 2D and 3D FEM code", Journal of Materials Processing Technology, Vol. 80-81, pp. 213-219, 1998. []



Tehrani, M. S.; Hartley, P.; Naeini, H. M.; Khademizadeh, H.; "Localised edge buckling in cold roll-forming of symmetric channel section", Journal of Thin-Walled Structures, Vol. 44, pp. 184-196, 2006. []

-
- ¹ Marc-Mentat
 - ² Profil
 - ³ element
 - ⁴ shell
 - ⁵ variance

Archive of SID