

Numerical and Experimental Investigation the Effect of Pulsating Blankholder on Formability of Aluminum Alloy in Deep Drawing Process

R. Dadkhah, A. Mostafapour

ABSTRACT

In this study, the effect of pulsating blankholder by using a new system for improving the formability of aluminum alloy has been investigated. By means of this system, in every pulsating cycle, at first the blankholder force has been removed, metal has been flowed into die and then to prevent excessive metal flow and wrinkles, the blankholder force by springs has been used.

Deep drawing of cylindrical cup has been simulated by using ABAQUS6.7 software. Cup depth, tearing and thickness distribution of the experimental and numerical results have been compared. The results show that cup depth by using the pulsating blankholder system and select a proper frequency and gap, can be increased and thickness distribution can be improved. It has further been observed that simulation and experimental results are in good agreement together.

KEYWORDS : Deep drawing, Pulsating blankholder, Finite element method

// :

// :

dadkhah.r@gmail.com :

i

ii

[]

/ / / /

[]

/ / /

Archive of SID

[]

()

[]

()



/ / / /

()

()

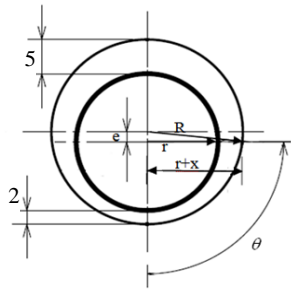

(:)

/

/

()

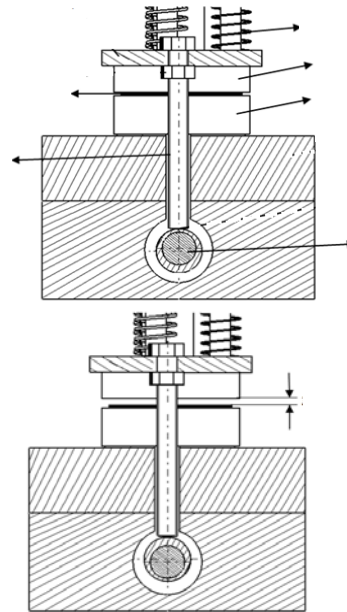

(:)

R e

$$x = \sqrt{R^2 - e^2 \sin^2 \theta} - (r + e \cos \theta)$$

(A))) ()))

())) ()))

$$\theta = \omega t$$

n

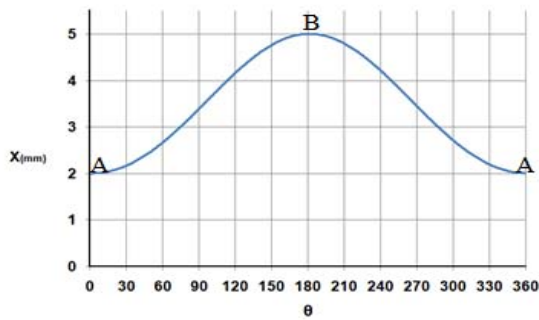

(:)

/

() ()

:()

/	
/	
/	
/	

S4R

[]

R3D4

ASTM

()

()

()

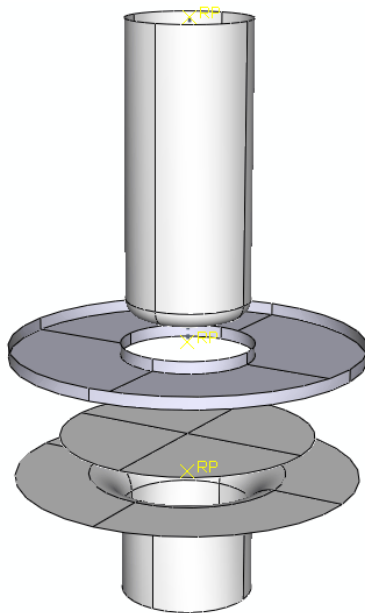

:()

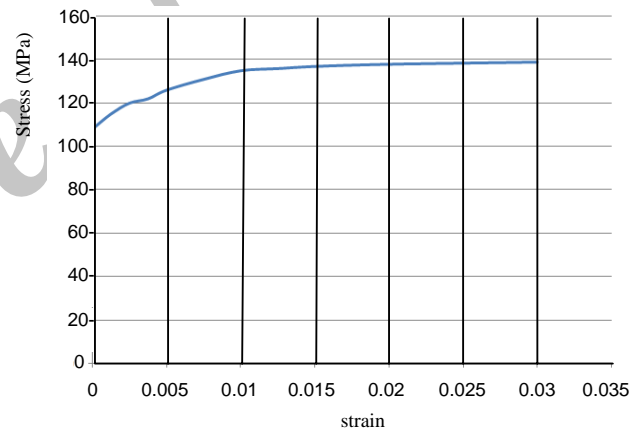

:()

:()

GPa	
/	
MPa	
/ gr/cm ³	
/	(r ₀)
/	(r ₄₅)
/	(r ₉₀)



/ / / /

()

()

()

$$F(t)_1 = kx = kvt \quad ()$$

$t \quad v \quad x \quad k$

$$F(t)_2 = k(vt + X(t)) \quad ()$$

$X(t) \quad t \quad k$

$$F_{BH} = F(t)_2 - F(t)_1 \text{ if } X(t) = 0 \quad F(t)_2 = 0 \quad ()$$

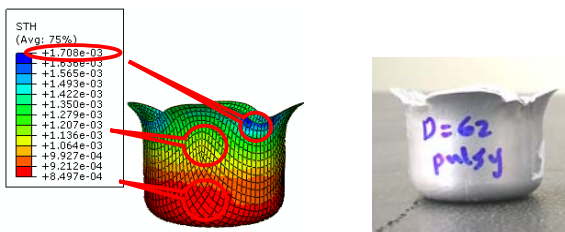
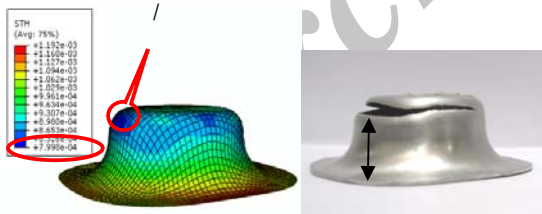
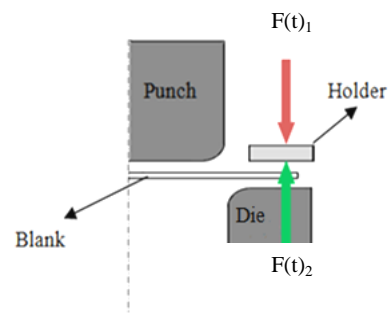

()

()

B A

()

A C

B

C

C A

B

()

()

()

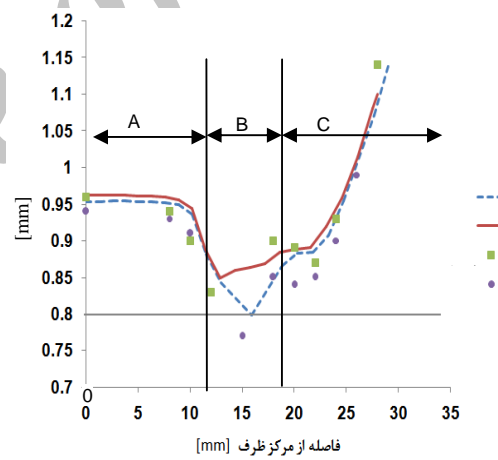

:()

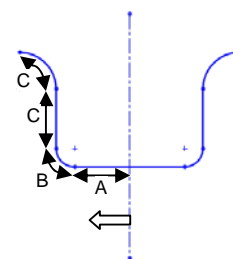

:()



/ / / /

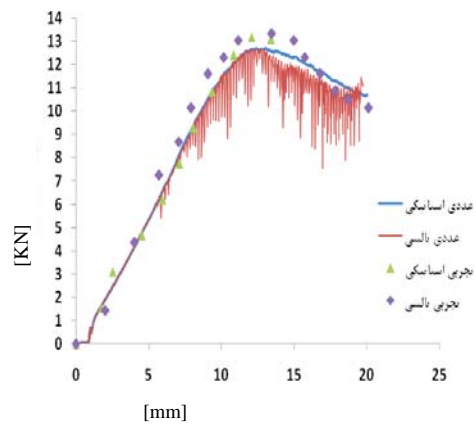

() :

()

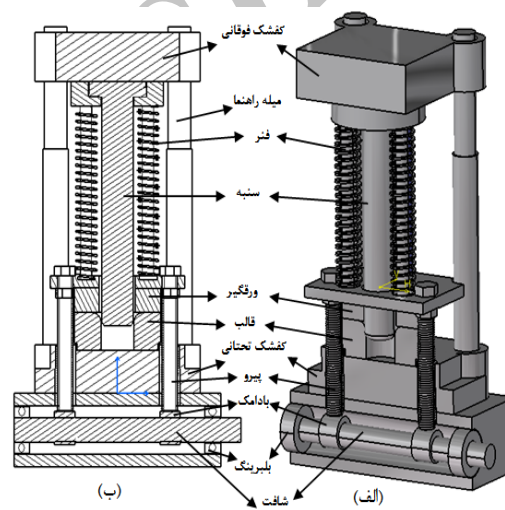

() :

Shiraz Ali; Hinduja, S; "The effect of ultra-low frequency pulsations on tearing during deep drawing of cylindrical cups", Int. J. of Machine Tools & Manufacture, 2007. []

Abaqus Version 6.7 Documentation.P []

Sheng, Z.Q. ; Jirathearanat, T; " Adaptive FEM simulation for prediction of variable blank holder force in conical cup drawing", Int. J. of Machine Tools & Manufacture, p.p.487-494,2003. []

Koyama, H. ; Manabe, K; " A database oriented process control design algorithm for improving deep-drawing performance", J. of Materials Processing Technology, p.p. 343-348, 2003. []

Gunnarsson, L; Schedin, E; " Improving the properties of exterior body panels in automobiles using variable blank holder force", J. of Materials Processing Technology, p.p. 168-173, 2001. []

Jimma, T; Kasuga, Y; " An application of ultrasonic vibration to the deep drawing process", J. of Materials Processing Technology, p.p. 406-412,1998. []

- 1 Abaqus
- 2 Inverter
- 3 Mass scale
- 4 Micro crack

/

/

/

/