

## ***Design and Manufacturing of a Vibration Absorber for Sound Reduction of a Turboprop Aircraft***

Hamed Malakooti Khah, Mahmood Mousavi M, Arash Golshah and Omid Mohamad Pour

### ***ABSTRACT***

The sound produced by the engine penetrates into the airplane through the structure and fuselage is still a grave concern for turboprop plane designers. The engine's propellers rotation is the main source of the sound in this kind of planes, the sound is transmitted to the fuselage through the structure and air so makes it vibrated. The decrease of noise made in the planes by dampers such as rubber, visco-elastic, and other non-dynamic absorber is not possible due to frequency low level. The present study investigates the designing of dynamic absorber for installing on the fuselage to absorb vibration and damping of the sound energy in the structure of the plane which makes the transmission way of vibration and sound possible in the structure. In the beginning, the theoretical relationship to design tunable dynamic absorber is gained, then the finite element model of the absorber is analyzed by ANSYS, and at the end, structuring and examining it for turboprop Antonov-140 is carried out.

**KEYWORDS :** Tunable dynamic absorber, Turboprop aircraft, Sound reduction, Vibration reduction, Finite element

---

/	/ / :	i
	/ / :	ii
arash_golshah2004@yahoo.com	/	iii
omid_m_pour@yahoo.com	/	iv

hamedmalakootikhah@yahoo.com

mmosavi@ut.ac.ir

Archive of SID



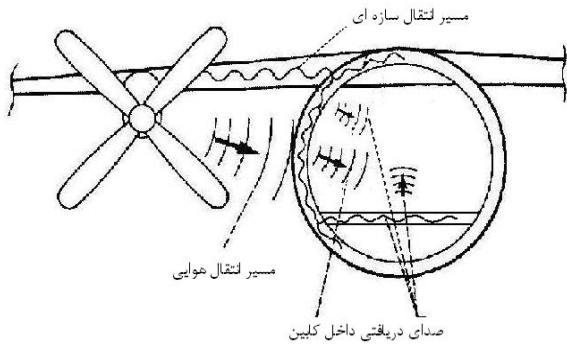

( )

Archive of SID

( )  
( )

( )

( )

$$f = \frac{n \cdot N}{\epsilon_0}$$

( )

( )

$n$

$N$

rpm

( )

( )

( )

( )

( )

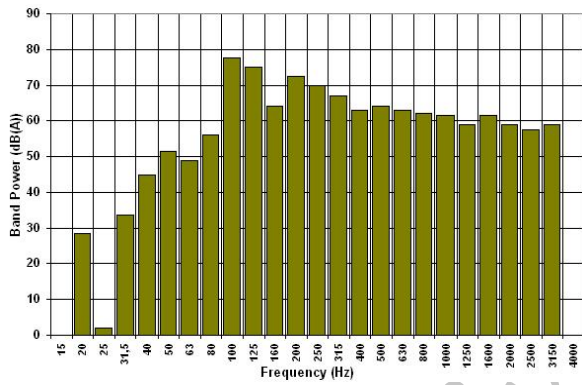

of SID

( )

dB

( )

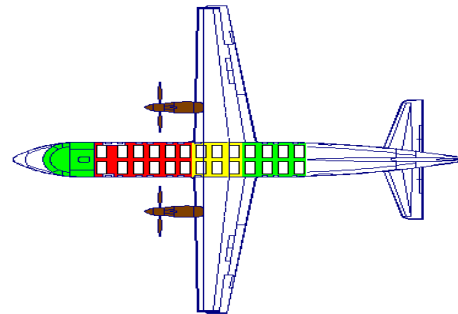
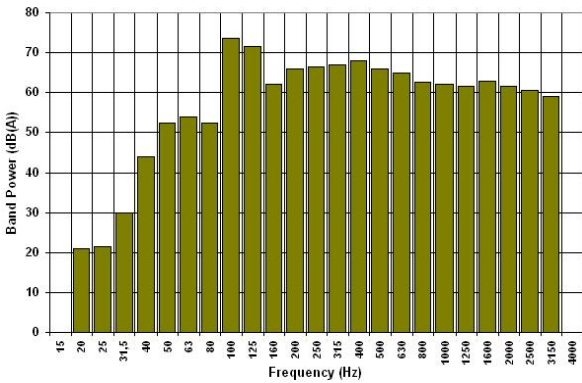

( )



( )

x

y

z



/ / / /

%

/

/

( )

[ ]

$$L_a(dB) = \gamma \cdot \log\left(\frac{A}{A_0}\right) \quad ( )$$

$$A_0 \quad L_a$$

$$A \quad \gamma \cdot \gamma^{\gamma} (m/s^{\gamma})$$

z y x

( )

[ ]

( )

$$\Delta SWL(dB) = \gamma \cdot \log(\dots - T) = \gamma \cdot \log(I_s) \quad ( )$$

$$T \quad \Delta SWL$$

$$I_s$$

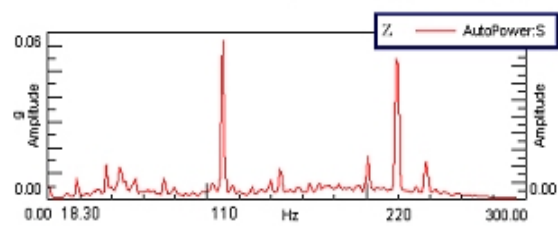
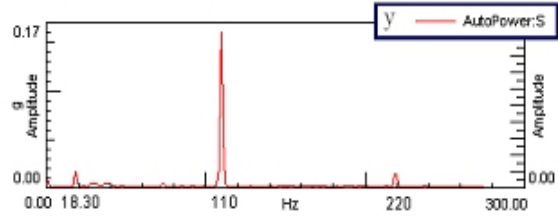
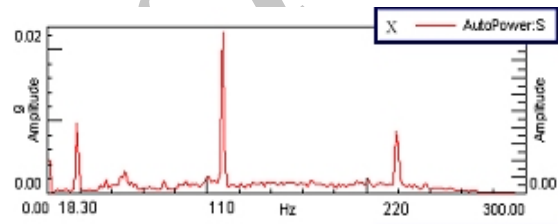

z y x

( )

Archive

/

/

/

/

$$\lambda = (\rho A \omega^2 / EI)^{1/4} \quad \omega^2$$

$$C_1, C_2, C_3, C_4$$

$$(1 + \cos \phi \cosh \phi) + \frac{m\phi}{\rho AL} (\cos \phi \sinh \phi - \cosh \phi \sin \phi) = \dots \quad (m)$$

$$(\phi = \lambda L)$$

$$\rho \quad L \quad A \quad m \quad \phi$$

$$[\ ] \omega_i = \phi_i^2 \sqrt{EI / \rho AL}$$

$$\begin{bmatrix} k_1 + \gamma k_r - m\omega^2 & -k_r & -k_r & \cdot & \cdot \\ -k_r & k_1 + k_r - m\omega^2 & \cdot & -k_r & \cdot \\ -k_r & \cdot & k_1 + k_r - m\omega^2 & \cdot & -k_r \\ \cdot & -k_r & \cdot & k_r - m\omega^2 & \cdot \\ \cdot & \cdot & -k_r & \cdot & k_r - m\omega^2 \end{bmatrix} \begin{Bmatrix} A_1 \\ A_2 \\ A_3 \\ A_4 \\ A_5 \end{Bmatrix} = \dots \quad (n)$$

$$f = \omega / \gamma \pi$$

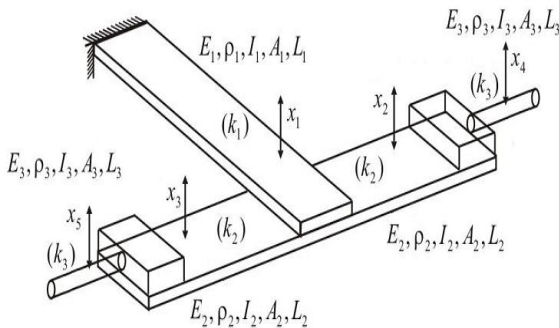

( )

(m) (k)

$$EI \frac{\partial^4 w}{\partial x^4} + \rho A \frac{\partial^2 w}{\partial t^2} = \dots \quad (k)$$

$$w(x, t) = \dots \quad (k)$$

$$\frac{\partial^2 w}{\partial x^2}(L, t) = \dots, \quad EI \frac{\partial^2 w}{\partial x^2}(L, t) = m \frac{\partial^2 w}{\partial t^2}(L, t) \quad (k)$$

$$w(x, t) = X(x) e^{i\omega t}$$

$$X(\cdot) = \dots, \quad \frac{dX}{dx}(\cdot) = \dots, \quad \frac{d^2 X}{dx^2}(L) = \dots, \quad EI \frac{d^2 X}{dx^2} = -m\omega^2 X \quad (k)$$

$$X(x) = C_1 \cos \lambda x + C_2 \sin \lambda x + C_3 \cosh \lambda x + C_4 \sinh \lambda x \quad (k)$$

$$X(\cdot) = \dots \rightarrow C_1 + C_2 = \dots, \quad \frac{dX}{dx}(\cdot) = \lambda C_1 - \lambda C_2 = \dots$$

$$\frac{d^2 X}{dx^2}(L) = \dots \rightarrow -\lambda^2 \cos \lambda L C_1 - \lambda^2 \sin \lambda L C_2 + \lambda^2 \cosh \lambda L C_3 + \lambda^2 \sinh \lambda L C_4 = \dots \quad (k)$$

$$\frac{EI}{m} \frac{d^2 X}{dx^2}(L) = -\omega^2 X(L) \rightarrow \left( \frac{\rho A}{m} \sin \lambda L + \lambda \cos \lambda L \right) C_1 + \left( -\frac{\rho A}{m} \cos \lambda L + \lambda \sin \lambda L \right) C_2 + \left( \frac{\rho A}{m} \sinh \lambda L + \lambda \cosh \lambda L \right) C_3 + \left( \frac{\rho A}{m} \cosh \lambda L + \lambda \sinh \lambda L \right) C_4 = \dots$$



11 Gpa  
CRES316

BT6

kg/m<sup>3</sup>

Gpa

Gpa

(k<sub>r</sub>)

L<sub>r</sub>

(k<sub>r</sub>)

( )

( )

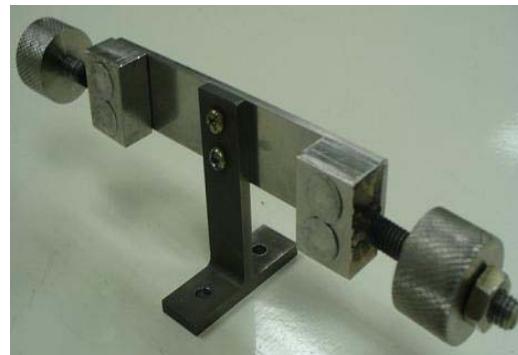

( )



( )

( )

[ ]

FFT

FFT

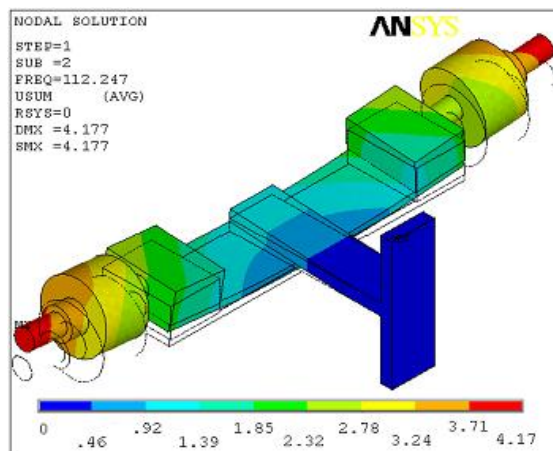

( )



( ) :

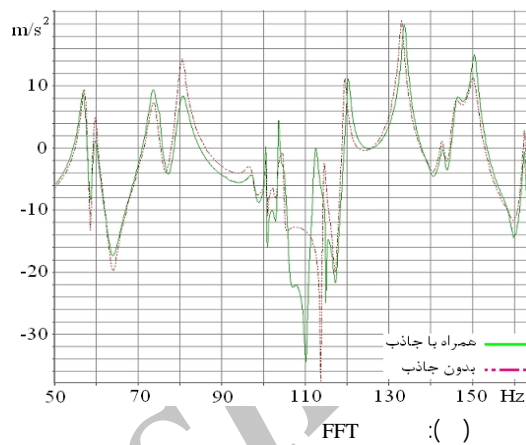

( ) :

( )

( )

( ) :

Hz	Hz	Hz	

Archive of SID

( )

M. Z. Kolovsky, "Nonlinear dynamics of active and passive systems of vibration protection", Springer Verlag, Berlin, 1999. [ ]

Linya Liu, Wenjie Shao, "Design and dynamic response analysis of rail with constrained damped dynamic vibration absorber", Procedia Engineering, Vol. No. 15, pp. 4983-4987, 2011. [ ]

P. Gardonio, "Review of active techniques for aerospace vibro-acoustic control", J. Aircraft 39(2), pp. 206-214, 2002. [ ]

D. B. Den Hartog; Mechanical Vibrations, McGraw-Hill, 1956. [ ]

R.E.D. Bishop, D.B. Welbourn, "The problem of the dynamic vibration absorber", Engineering 174, 796, 1952. [ ]

P. H. Wirsching, G. W. Campbell, "Minimal structural response under random excitation using the vibration absorber", Earthq. Engng. Struct. Dynam. 2, pp. 303-312, 1974. [ ]





- R. Vinayak, M. K. Ghosh, "Forced vibration response of thin plate with discrete dynamic absorbers", *Thin-Walled Structures* 43, pp. 1513-1533, 2005. [ ]
- Zhaohui Sun, Jincai Sun, Chong Wang, Yang Dai, "Dynamic vibration absorbers in structural vibration control under multi-frequency harmonic excitations", *Applied Acoustics*, Vol. No. 48, pp. 311-321, August 1996. [ ]
- Yii-Mei Huang, Chun-Cheng Chen, "Optimal design of dynamic absorbers on vibration and noise control of the fuselage", *Computers & Structures*, Vol. No. 76, pp. 691-702, 30 July 2000. [ ]
- R. Golmohamadi; *Noise & Vibration Engineering*, Daneshjoo Press, 2004. [ ]
- S. Graham Kelly; *Theory and Problems of Mechanical Vibrations*, Schaum's Outline Series, McGraw-Hill, The United States of America, 1996. [ ]
- ANSYS 12.0. User's Reference Manual, 2008. [ ]
- Y.M. Huang, C.R. Fuller, "The effects of dynamic absorbers on the forced vibration of a cylindrical shell and its coupled interior sound field", *Journal of Sound and Vibration*, Vol. No. 200, pp. 401-418, 6 March 1997. [ ]
- W. O. Wong, Y. L. Cheung, "Optimal design of a damped dynamic vibration absorber for vibration control of structure excited by ground motion", *Engineering Structures*, 2006. [ ]
- J. P. Den Hartog; *Mechanical Vibrations*, Dover Publication Inc, 1985. [ ]
- B. G. Korenev, L. M. Rezinkov, "Dynamic vibration absorbers", *Theory and Technical Applications*, John Wiley & Sons, 1993. [ ]
- He Ye Xiao, Mei Ping Sheng, Ye Lei, "A new type dynamic vibration absorber to reduce broad-band vibration in plates", *Advanced Materials Research*, Vol. No. 148-149, pp. 485-497, 2010. [ ]

Archive of SID