

Design and Development of a New Physical Model of Strip Footings on Reinforced Soil Media under Cyclic Loadings

S. Abrishami; S. M. Mir Mohammad Hosseini

ABSTRACT

To design the engineering structures properly, some relevant information is required main part of which can only be obtained from modeling them. Physical modeling, if carried out carefully, can present such valuable information in connection with structural behaviors that may implement to calibrate the numerical modeling or to verify the designing assumptions. In geotechnical problems however, the physical modeling, due to their inherent complexity and dependency to many factors, are of great importance and may submit very useful and crucial data.

In this paper, a new physical model capable for studying the behavior of strip footings on reinforced soil under monotonic and cyclic loadings is presented. The design criteria and specification of different

Email: mirh53@yahoo.com

Email: saeedabrishami@yahoo.com

i

ii

parts of the model are explained and discussed. In order to control the ability and accuracy of the model, regarding the responses of strip footings subjected to different static and cyclic loadings, the results of some tests have been compared with other empirical and theoretical data. The consistency between the results shows the reliability of the developed model.

KEYWORDS

Physical Modeling, Bearing capacity, Strip Footing, Cyclic Loading, Permanent Settlement

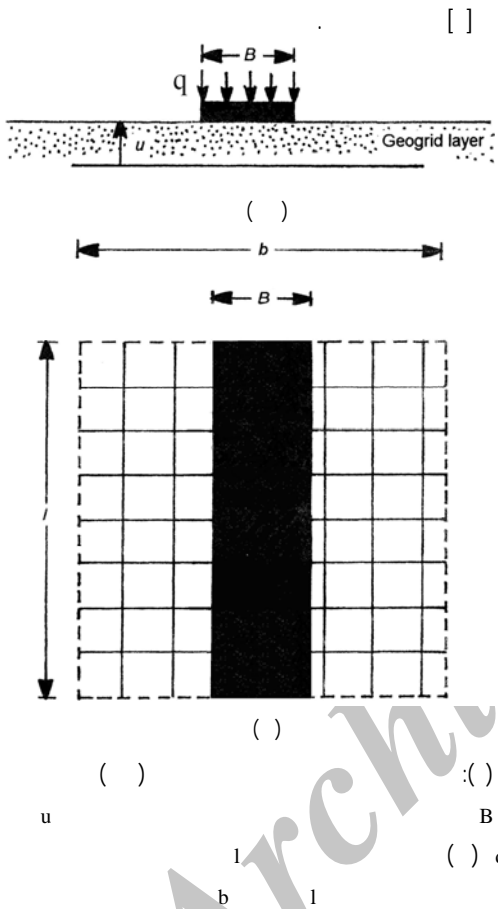

[]

()
()

[] [] [] [] []

[]

()

()

(Hz)

()

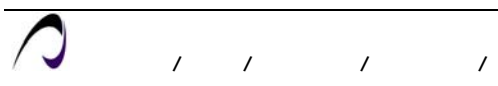

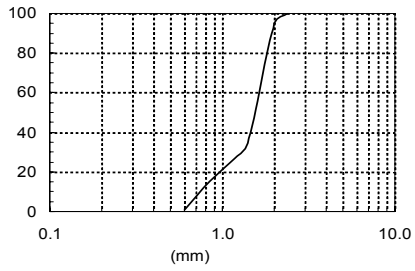

:()

/ .[]

ABAQUS

[]

()
) / mm

cm

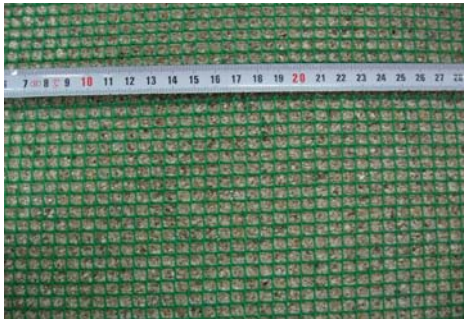

(

:()

()

/ %

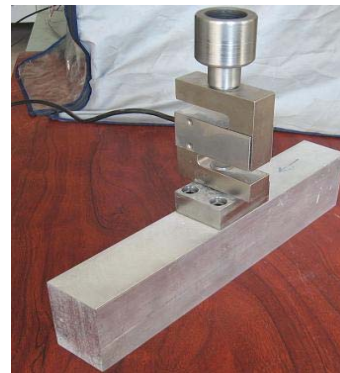

Loadcell :()

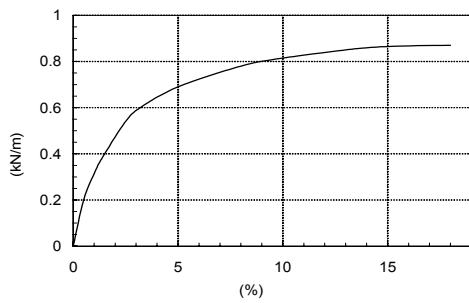

:()

()

()

/ cm

B [] [] []

FLAC []

cm

cm

B

[]

Plaxi Glass

cm

cm

(

)

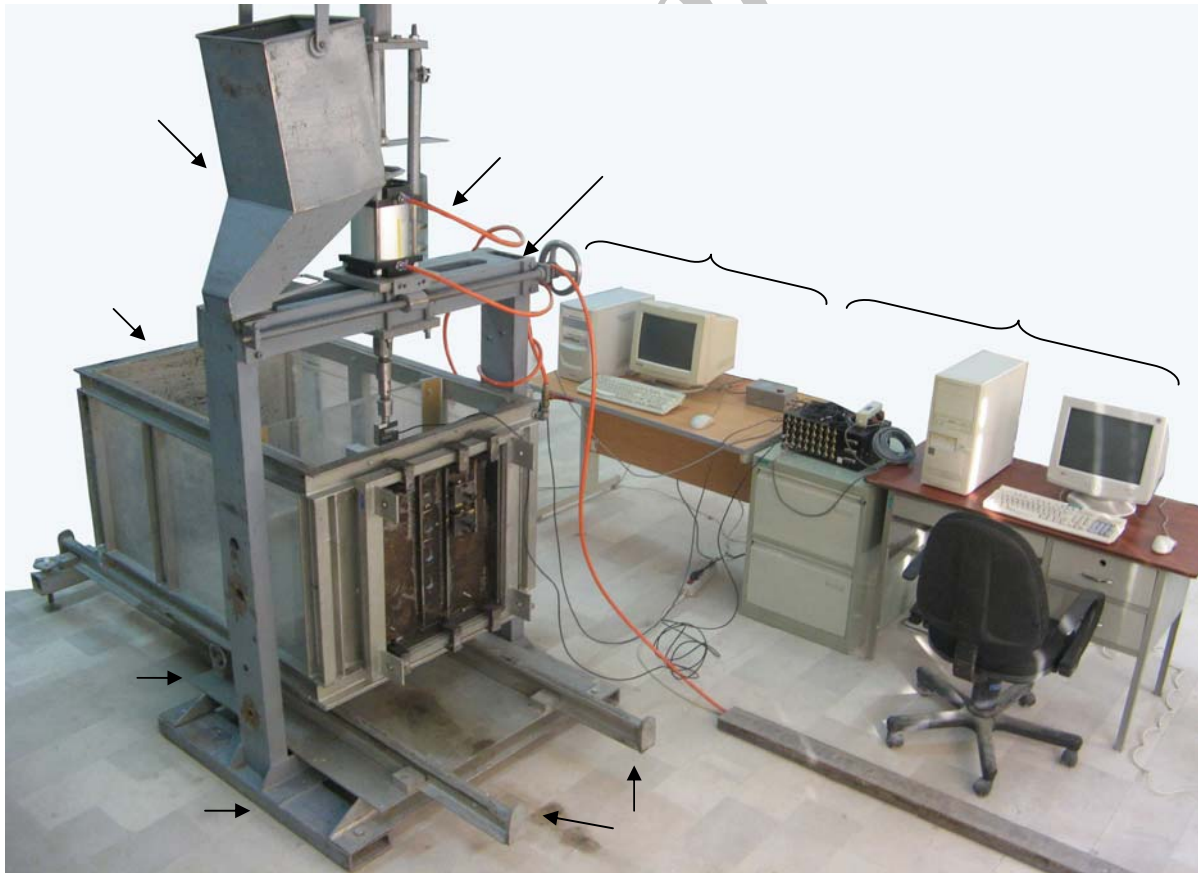

(:)



/ / / /

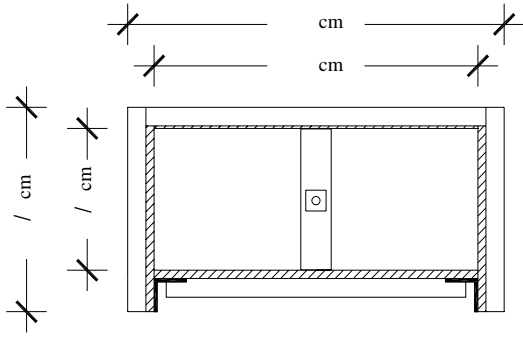

()

(L * UNP)

■ Steel sections

▨ Plaxi glass sections

()

: ()

()

()

()

()

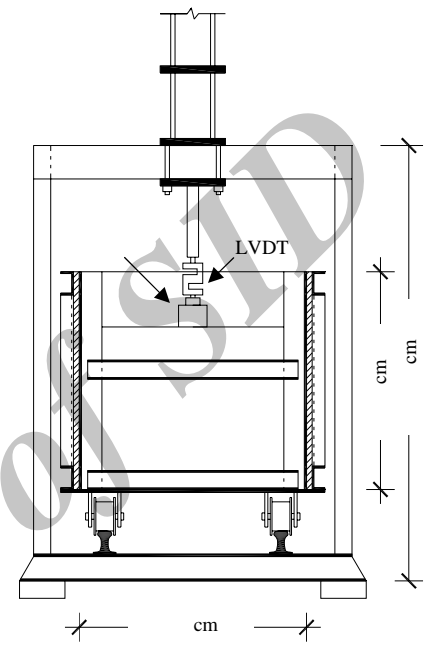

()

Archive

[]

([] [])

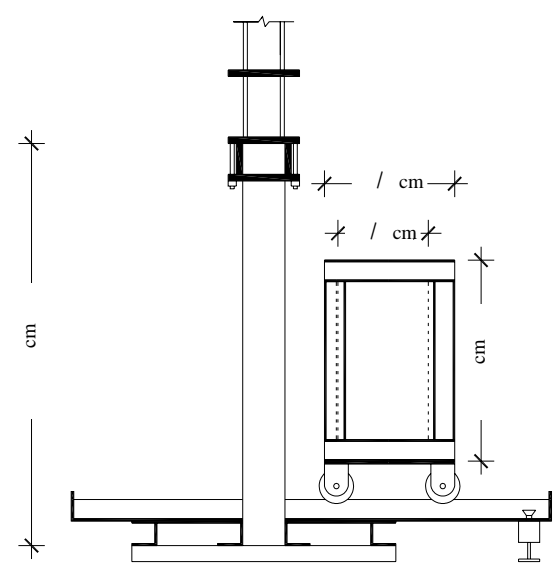

()

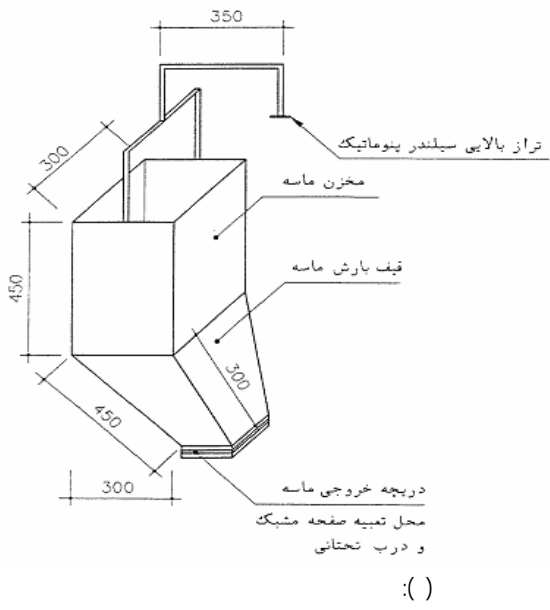

()

()

cm

()

()

()

() EP

bar

ton

mm



/ / / /

()

/ cm

()

EP

/ ton

() S

Loadcell

/ mm

() LVDT

cm

m/s



(LVDT)

:()



EP :()

Hz

EP

A/D

cm

()



:()

Hz

EP

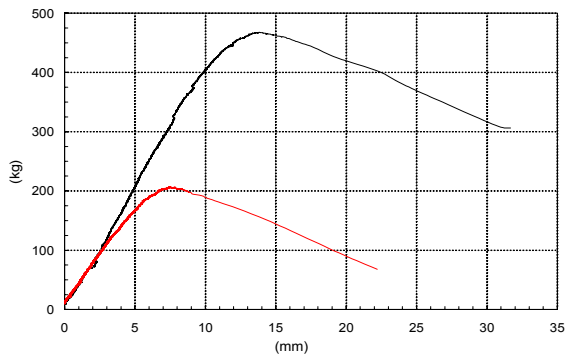

Data Logger

Logger

()

() : ()

() (u/B= /)

[]

()

$$q_u = 0.5\gamma BN_\gamma \quad ()$$

()

N_γ

$$q_u = \gamma \quad / \text{ kN/m}$$

()

$$Q_u = \quad / \text{ kg}$$

()

$$q_u = \quad / \text{ bar}$$

$$N_\gamma = \quad /$$

([] [] [])

()

/

(BCR_u)

(SR_u)

$$BCR_u = (q_u)_R / (q_u)_{UR} \quad ()$$

$$SR_u = (S_u)_R / (S_u)_{UR} \quad ()$$

$$(q_u)_{UR} \quad (q_u)_R$$

$$(S_u)_{UR} \quad (S_u)_R$$

()

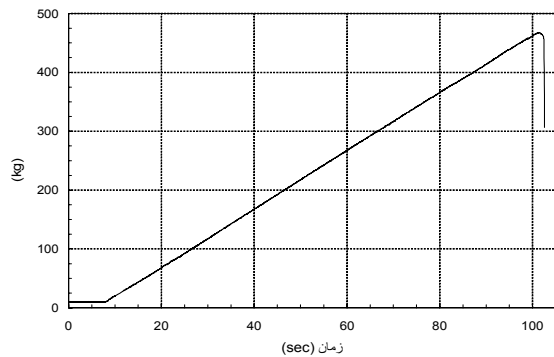

(u)



/ / / /

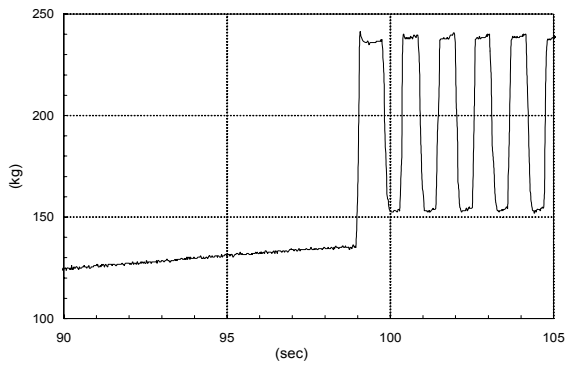

()

u/B

[] []

[]

()

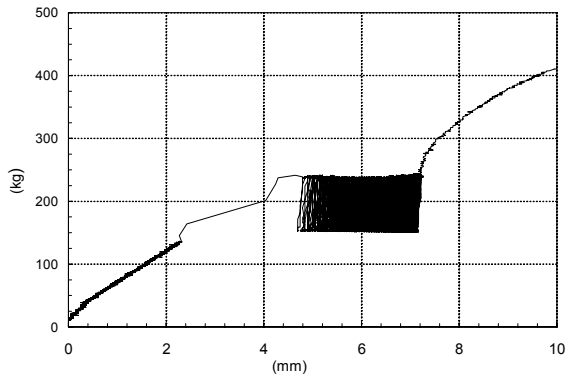

()

()

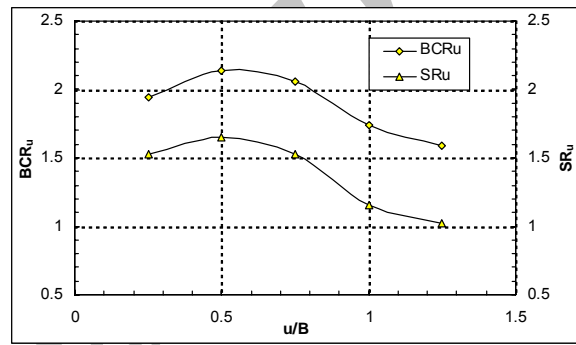

()

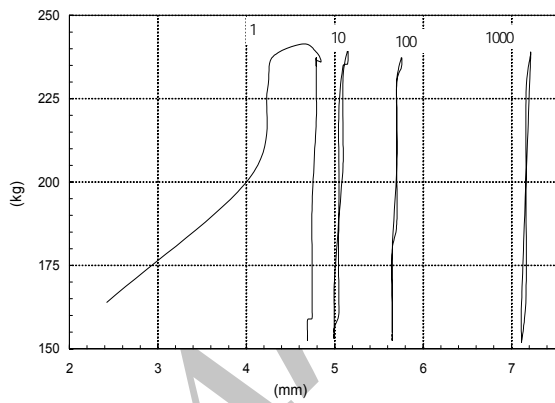

()

kg

()

($q_u/$) kg

($q_u/$)

()

()

()

() ($u/B = /$)

()
()

()

($q_u/$) kg ($Q_u/$) kg

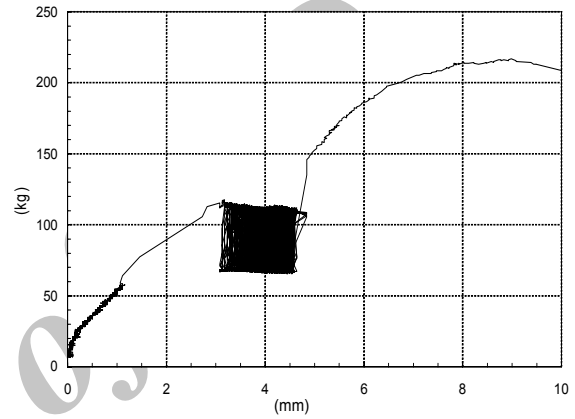

:()

Archive

[]

[]

[]

()

[]

(S_R)

:()

(S_{UR})

Chen, Q.; An Experimental Study on Characteristics and Behavior of Reinforced Soil Foundation , PhD Thesis, Louisiana State University, 2007.

Patra, C. R.; Das, B. M.; Atalar, C.; "Bearing Capacity of Embedded Strip Foundation on Geogrid Reinforced Sand", Geotextiles & Geomembranes, vol. 23, p.p. 454-462, 2005.

[]

[]

S_R/S_{UR} (%)	$S_{UR}/(S_u)_{UR}$ (%)	$S_R/(S_u)_R$ (%)	
/	/	/	
/	/	/	
/	/	/	
/	/	/	



- Patra, C. R.; Das, B. M.; Bhoi, M.; Shin, E.C.; []
“Eccentrically Loaded Strip Foundation on
Geogrid Reinforced Sand”, Geotextiles &
Geomembranes, vol. 24, p.p. 254-259, 2006.
- Pfeifle, T. W.; Das, B. M.; “Model Tests for []
Bearing Capacity in Sand”, Journal of
Geotechnical Engineering, vol. 105, p.p. 1112-
1116, 1979.
- Sitharam, T. G.; Sireesh, S.; “Behavior of []
Embedded Footings Supported on Geogrid Cell
Reinforced Foundation Beds”, Geotechnical
Testing Journal, ASTM, vol. 28, p.p. 452-463,
2005.

