

1387 -28
49 80

()

** _ *

Archive of SID

.86/12/16 :

86/8/14 :

*

**

"

(1998) .[Torset, 2001]

" "

" "

"

[Liedtka, 1998]

(2005)

.[Torset, 2001]

)

	1993	1994	1982	:
1994	1998	1996	1993	1993
	(2005	2001	1998	1998

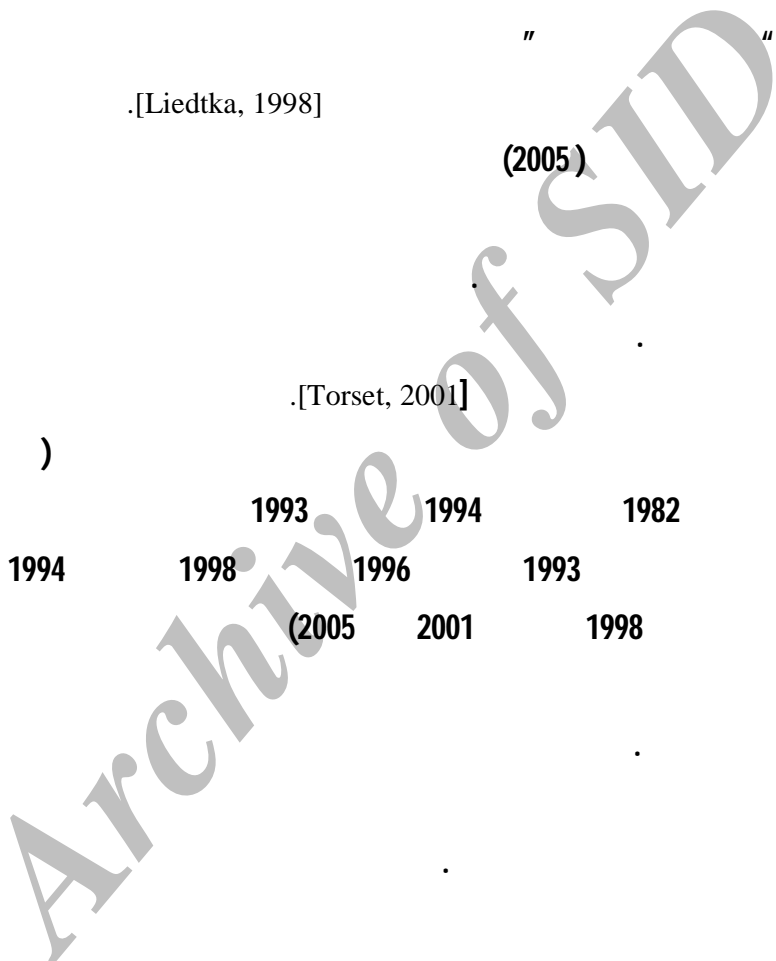

(2001)

1998

1998

.)
:

.(2005

.[Bonn, 2005]

10

":
"

(1978)

":
"

Archive of SID

1

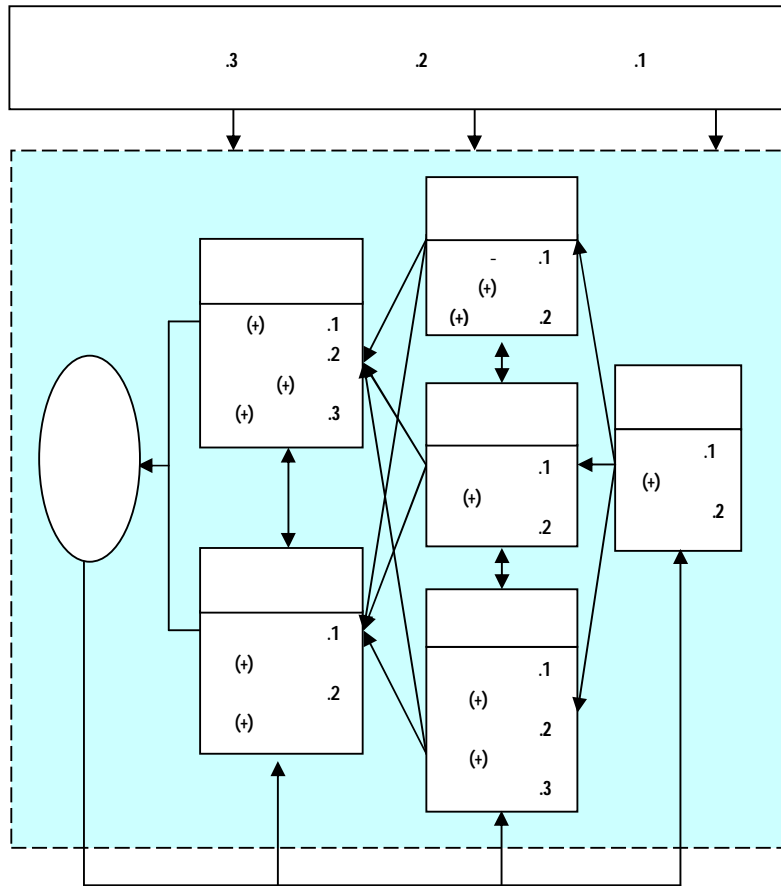

.1

(

.(231 :1996)

1" "

1997 :)

.(1990 191 1989

(1994) .(1991)

(1993) (1980 1985 1990) (1982)

3" " 2" "

4" "

(

1982 :)

.(1994

-
- 1. Anticipation
 - 2. Process
 - 3. Content
 - 4. Context

(1998)
 (2005) (2005) (2001)

:)

.(1998 1997 1996

": (1996)

.(1984)

" (1995)

"

Archive of SID

" "

(1998)

[Liedtka, 1998]

" "

(1991)

:

)

[Graetz, 2002]

[Liedtka, 1998]

(1990)

(1996)

Archive of SID

(1996)

.[Liedtka, 1998]

(2001)

(1998)

(2001)

(1998)

1

(1998)

(2001)

Archive of SID

1. Dialogue

(1998) :

" "

1980)

(1985 1990

(1998)

Archive of SID

1. Grassroots

()

(1993)

1987

1983

:

)

1987

1980

1989

1973

(1982

1980

1983

1. Contextual Factors

(1993)

.[Pettigrew, 1993]

.(1996)

(2001)

(2001)

(1376)

(1982 1984)

Archive of SID

.
 :)
 (1994 1996 1990 1986
 1994 1993 :)
 (1993) (1997
 . (1998 :)
 .[Torset, 2001] " "
 .
 :
 . " " "
 .
 .[Heracleous, 1998] [Boon, 2005]
 (1970) .

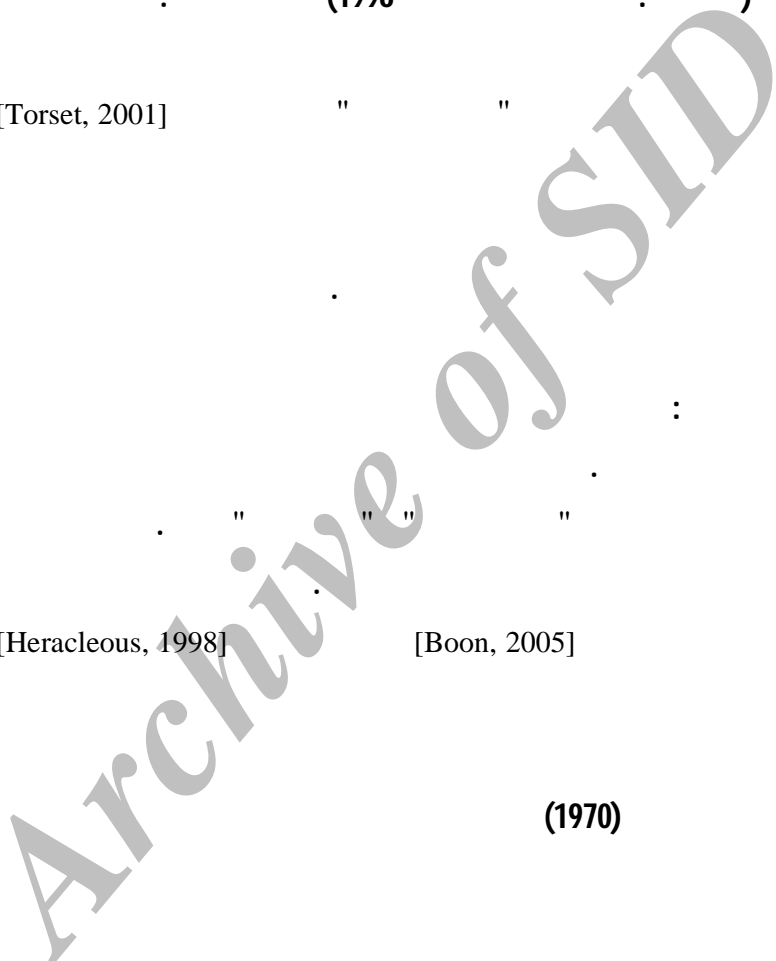

(1983)

(1734)

(1975)

(1975)

(1948 1949)

Mintzberg, 1994; Boon, 2005;]

Archive of SID

.[Liedtka, 1998

Archive of SID

(1991)
1
(1989) (1993)
(1994) (1986) (1992)
(2005)

1. Intersubjectively

)

(1994)

(1997)

(1991)

(1989)

(1995)

(1996)

(1988)

Archive of SID

(1992

(1982)" " " "
) (1999)
)

(

(1996)

(1999)

(1989)

Archive of SID

[Boon, 2005]

(1961)

(1977)

1

1. Idea Initiation

(1988)

(1985)

1"

"

)

(2002)

(1998)

(1990

1. Authoritarian

1 (2001) .(2000)

10 5

(2000)

1. Forum

(2000)

(1989)

(1998)

1970 1960

(1967)

(1965)

(1967)

(2001)

Archive of SID

1988 :)
1999 1995 1989 1988
2001 2001 2001 2000
. (2005

Archive of SID

[1998]

[Robbins, 1983]

1979 :)

2001

1990

1996

(2005

2003

(1993)

:

()

2"

" 1"

" :

1

393

-
- 1. Factor Analysis
 - 2. Structural Equation Model

.1

()				
) - (1
-				
-				
-				
-				
-				
-				
-				
-) (
-				

Archive of SID

- -				
- -				
IT - - - -				
-				
- - -				
() -				
- - -				2
- -				

"	" "	" .8
"	" "	" .9
"	" "	" .10
"	" "	" .11
"	" "	" .12
"	" "	" .13
"	" "	" .14
"	" "	" .15
"	" "	" .16
"	" "	" .17
"	" "	" .18
"	" "	" .19
"	" "	" .20
3	2	0.1
		RMSEA

Archive of SID

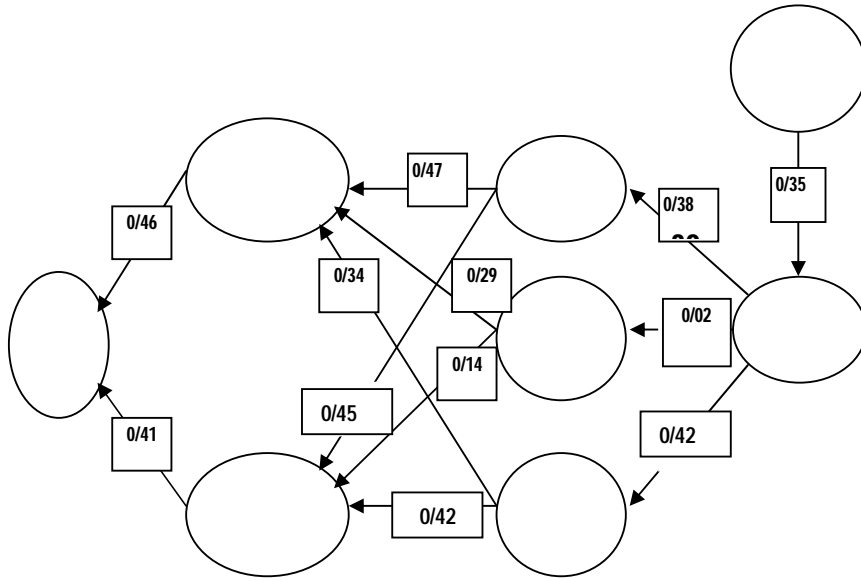

.2

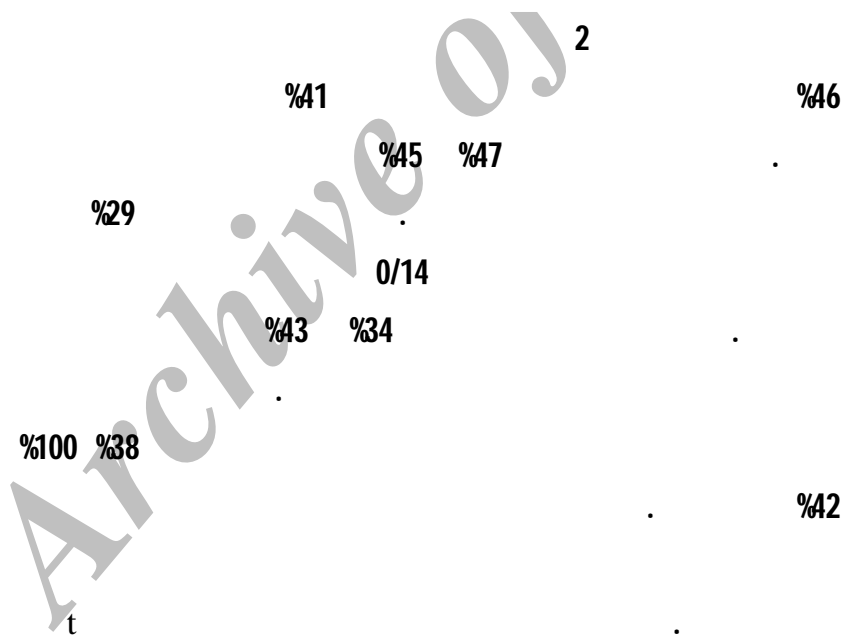

3

t

1/96

H_0

H_0

H_1

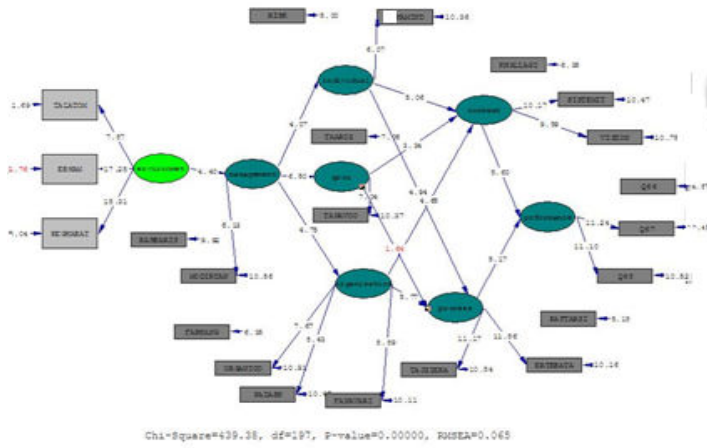

.3

Arch

20 19 18 .

2 .

.2

					1
					2
					3
					4
					5
					6
					7
					8
					9
					10
					11
					12
					13
					14
					15
					16
					17
					18
					9
					20

5

Archive of SID

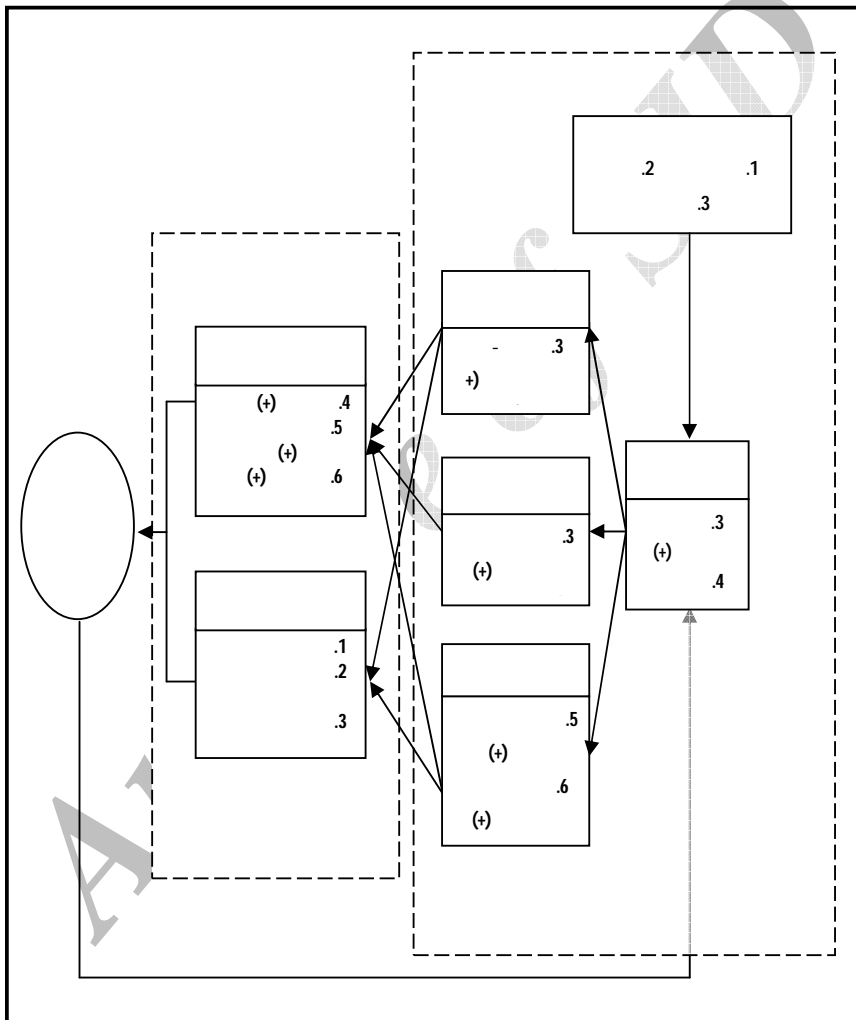

: " " (1998) .1

2. Bonn, Ingrid (2005), "Improving Strategic Thinking: A Multilevel Approach Leadership & Organization", *Development Journal*, Vol. 26, No. 5, pp.336-354.
3. Graetz, Fiona (2002), "Strategic Thinking versus Strategic Planning Towards Understanding The Complementarities ",*Management Decision*, Vol. 40, No. 5, pp: 456-462.
4. Heracleous, Loizos (1998), "Strategic Thinking or Strategic Planning"? *Long Range Planning*, Vol. 31, No. 3, pp: 481-487, 1998.
5. Koontz, Harold and Weihrich, Heinz (1993), "*Management: A Global Perspective*", 10th ed., International Edition, McGraw-Hill Series in Management.
6. Liedtka, Jeanne M. and Rosenblum, John W. (1996), "Shaping Conversations: Making Strategy, Managing Change", *California Management Review*, Fall.
7. Mintzberg, Henry (1994), "*The Rise and Fall of Strategic Planning*", New York Ny: The Free Press.
8. Pettigrew, Andrew, and Whipp, Richard (1993), "Managing Change For Competitive Success", *Oxford, UK: Blacwell Publishig*.
9. Robbins, Stephen PP: (1983), "*Organization Theory: Structure, Design, and Applications*", 2nd ed., Prentice-Hall International Editions.
10. Torset, Christophe (2001), "*Strategic Thinking: Why, What, and How? – An Organizational Model of Strategic Thinking*", Egos XVIIth Colloquim, Lyon, France.
11. Zabriskie, Noel B. and Huellmantel, Alan B. (1991), "Developing Strategic Thinking in Senior Management", *Long Range Planning*, Vol. 24, No. 6, pp: 25 -32.