

// : // :

(BOD)
(BOD)

(DO)

Archive of SID

(BOD)

(Little, and

Williams, 1975)

(ANFIS)¹

(Jang, 1993)

(1975) Yih, and Davidson
(1998) Mulligan and Brown

Van Griensven,

(2002)

()

(Jang and Gulley,

.1995)

(DO)

()

(Chang and

.Chang, 2001)

()

:(Nayak, et al., 2004)

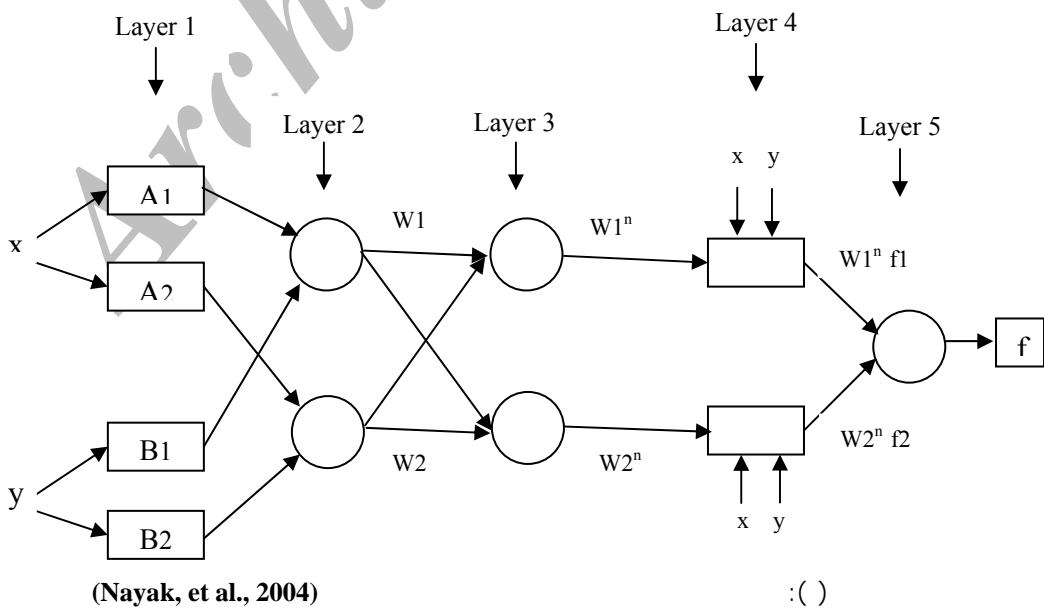

()

(RMSE) (R²)

(NMSE)

(MAPE)

:

$$R^2 = \frac{\sum_{i=1}^n (x_i - \bar{x})(\hat{x}_i - \bar{\hat{x}})}{\left(\sum_{i=1}^n (x_i - \bar{x})^2 \sum_{i=1}^n (\hat{x}_i - \bar{\hat{x}})^2 \right)^{\frac{1}{2}}} \quad (1)$$

$$RMSE = \left[\frac{1}{n} \sum_{i=1}^n (x_i - \hat{x}_i)^2 \right]^{\frac{1}{2}} \quad (2)$$

$$NMSE = \frac{\sum_{i=1}^n (x_i - \hat{x}_i)^2}{\sum_{i=1}^n (x_i - \bar{x})^2} \quad (3)$$

$$MAPE = \frac{1}{n} \sum_{i=1}^n \frac{|x_i - \hat{x}_i|}{x_i} \quad (4)$$

n \hat{x}_i x_i
x% (TS_x)

$$TS_x = \frac{Y_x}{n} \times 100 \quad (5)$$

Y_x
n x% (APE)
x%

()

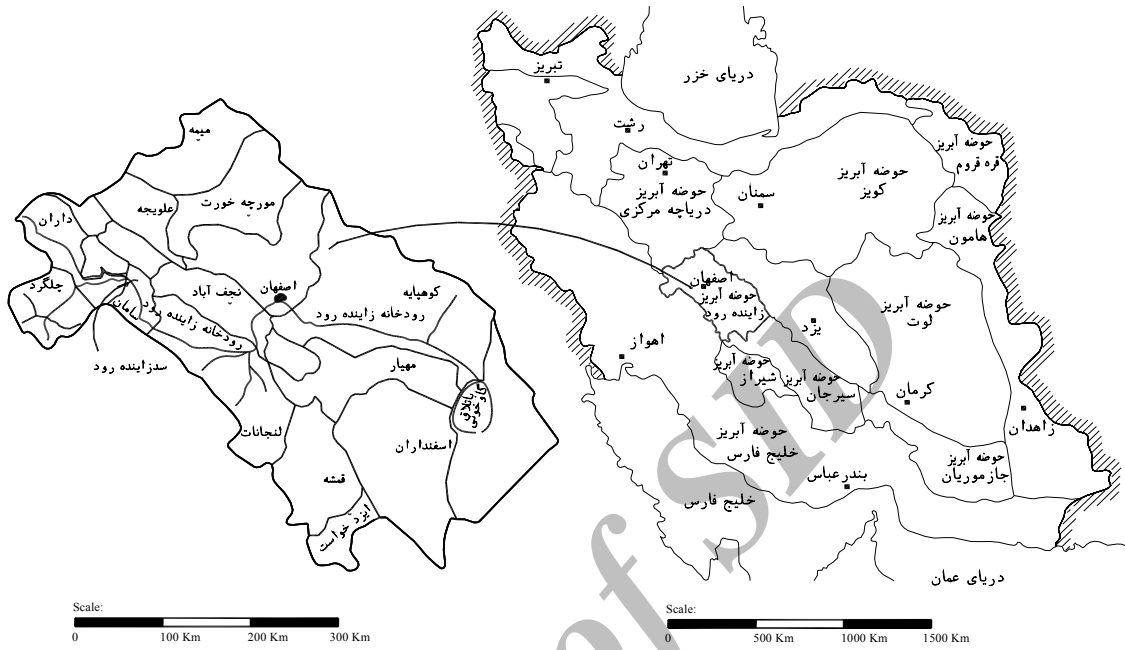

() :

()

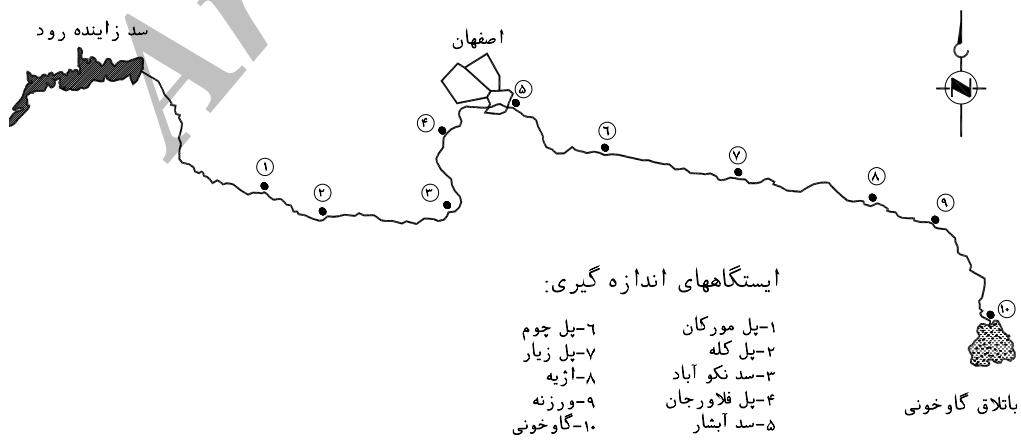

() :

DO BOD : ()

(mg/l)	(mg/l)	(mg/l)	(mg/l)	
/	/	/	/	BOD
/	/	/	/	DO

BOD

(MATLAB 7.4)

()

ANFIS

BOD

()

NF3 NF2 NF1

:

BOD

(T)

(Q)

BOD

(V)

(d)

ANFIS

BOD

:

DO

(T)

(Q)

(NF1)

DO

(V)

(W)

(d)

BOD

BOD

()

(TSx)

()

DO BOD

NF1

BOD		ANFIS		RMSE		R ²			
MAPE		NMSE							
/	/	/	/	/	/	/	/	BOD ₁ , BOD ₂ , T, Q	NF1
/	/	/	/	/	/	/	/	d, V, BOD ₁ , BOD ₂ , T, Q	NF2
/	/	/	/	/	/	/	/	d, V, T, Q	NF3

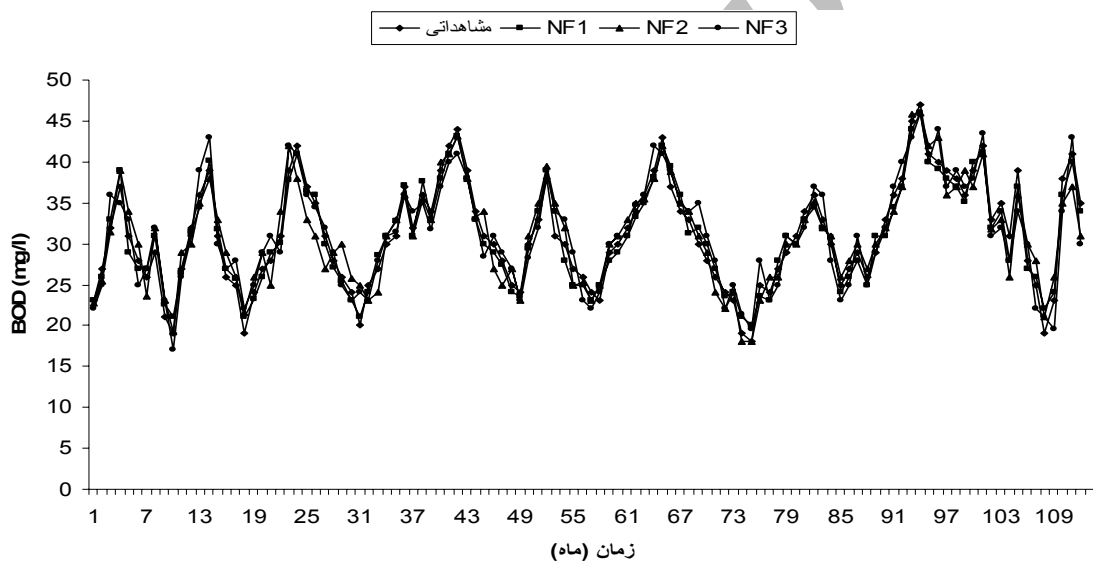

(NF3, NF2, NF1) BOD : ()

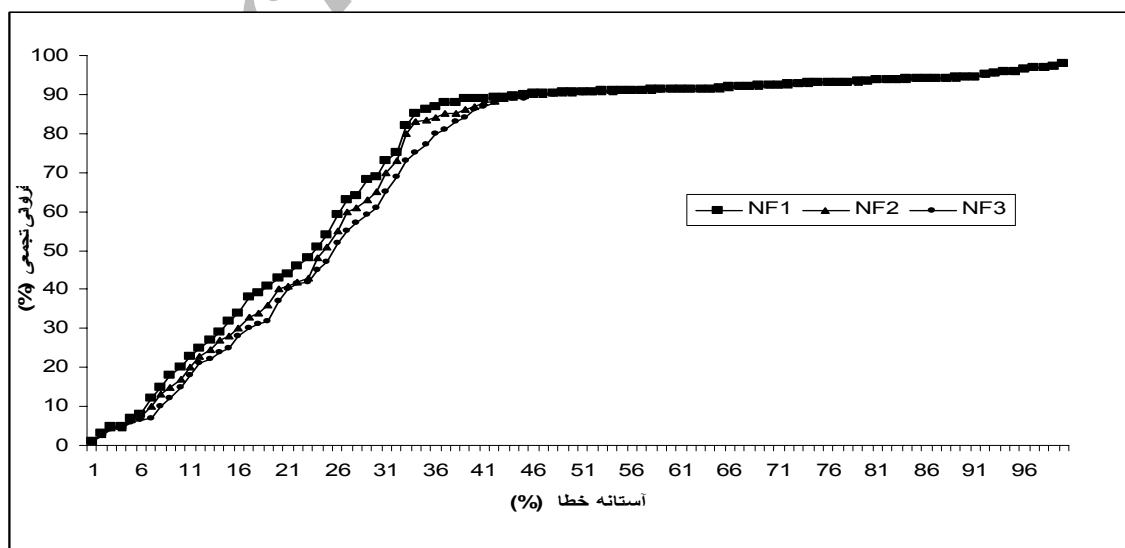

(NF3, NF2, NF1) : ()

NF6 NF5 NF4

()

ANFIS

()

DO

DO

ANFIS

:()

MAPE		NMSE		RMSE		R ²			
/	/	/	/	/	/	/	/	DO ₋₁ , W, T, d, V	NF4
/	/	/	/	/	/	/	/	d, DO ₋₁ , DO ₋₂ , T, Q	NF5
/	/	/	/	/	/	/	/	d, W, DO ₋₁ , Q	NF6

—●— مشاهداتی —■— NF4 —▲— NF5 —●— NF6

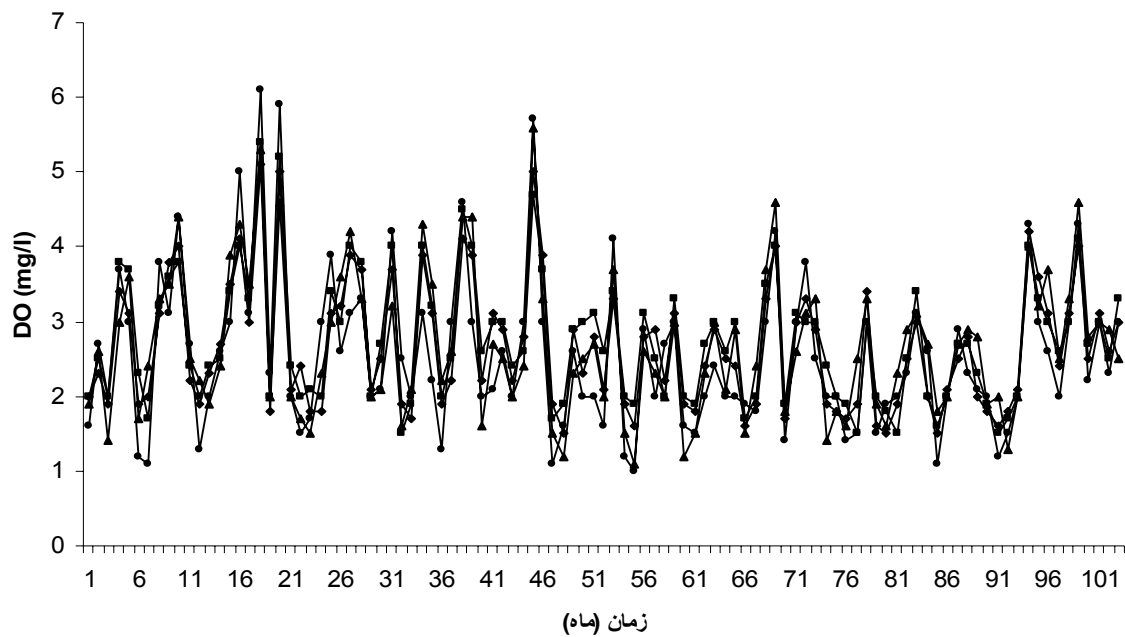

(NF4, NF5, NF6)

DO

:()

()

DO

(TSx)

ANFIS

()

(NF4)

NF4

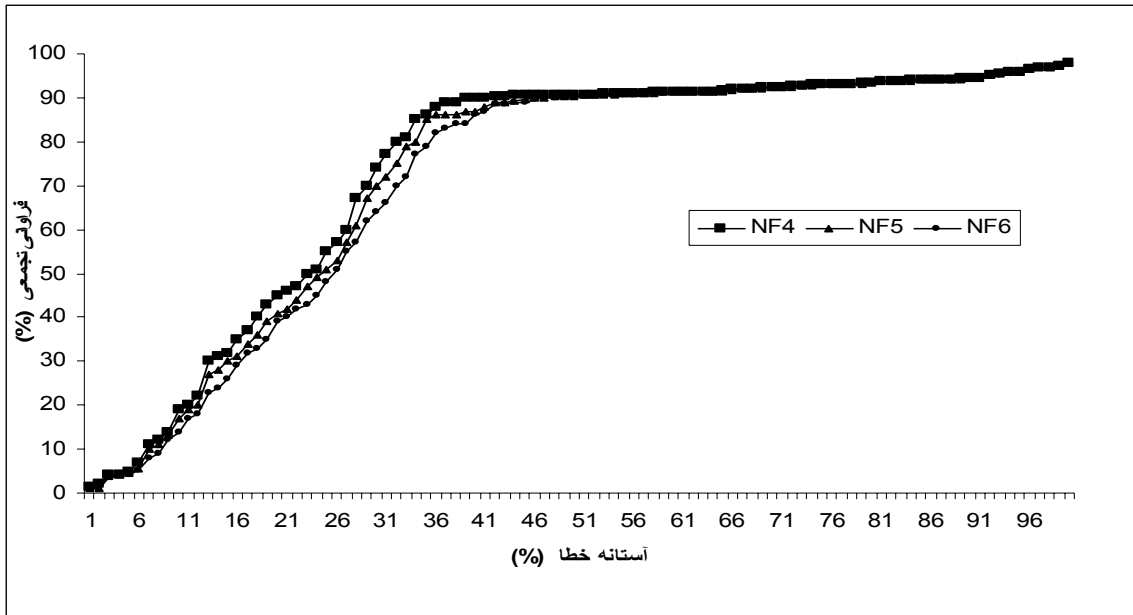

(NF6, NF5, NF4)

: ()

Archive

(TDS)

(COD)

/
/

/
DO

BOD

/

(DO

BOD

)

یادداشت

1-Adaptive Neuro Fuzzy Inference System
(ANFIS)

() .

Chang,L.C. and F.L.,Chang. 2001. Intelligent control for modeling of real-time reservoir operation. Hydrological Processes, 15, 1621-1631.

Jang,J.S.R. 1993. ANFIS: Adaptive-network-based fuzzy inference systems. IEEE Transaction Systems, Man. and Cybernetics. 23, 665-685.

Jang,J.S.R. and N.,Gulley. 1995. The Fuzzy Logic Tool Box for Use with MATLAB. The Mathworks Inc. Natick, MA.

Little,K.W., and R.E.,Williams. 1975. Least-squares calibration of QUAL2E. Water Environment Research, 64(2), 179-185.

Mulligan,A.E., and L.C.,Brown. 1998. Genetic algorithms for calibrating water quality models. Journal of Environmental Engineering, 124 (3), 202-211.

Nayak,P.C.and et al. 2004. A Neuro-fuzzy computing technique for modeling hydrological time series. Journal of Hydrology, 291, 52-66.

Van Griensven,A., A.,Francos, and W.,Bauwens. 2002. Sensitivity analysis and auto calibration of an integral dynamic model for river water quality. Water Science and Technology, 43(7), 321-328.

Yih,S.M., B.,Davidson. 1975. Identification in nonlinear, distributed water quality models. Water Resources Research, 11 (5), 693-704.