

*

(II , III , II)

:

:

(-)

$M_s = /$

[]

)

(

Stafford- [] Polyakov
 [] Carter Smith
 Holmes

[]
 () ()
 [] ()
 Fiorato
 []

[]
 Mehrabi
 []

[] ()

Bertero & Klinger :
 [] Kahn Hanson []
 Kwan [] Brokken Bertero
 [] & Liauw
 Tomazevic
 Zarnic

[]
 Al-Chaar

[] () []
 Colangelo

()

(1/2)

()

()

[]

()

ton

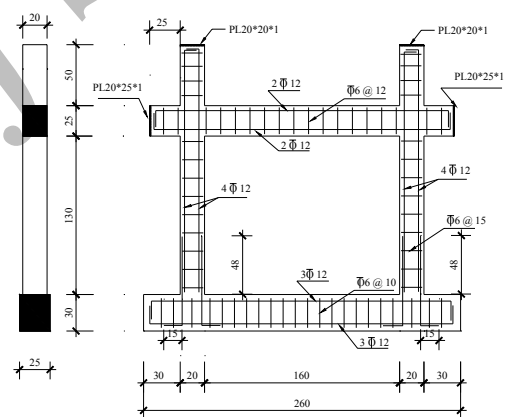

شکل ۱: ابعاد (cm) و جزئیات آرماتورگذاری نمونه‌ها.

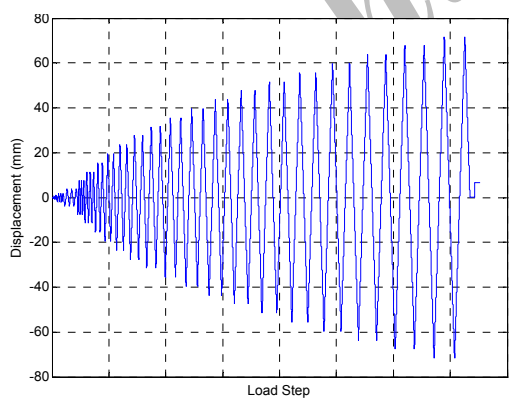

شکل ۲: تاریخچه بارگذاری نمونه‌ها.

جدول ۱: میانگین مشخصات مصالح.

			(Kg/Cm ²)	(Kg/m ³)
	* *			
			/	-
	* *			

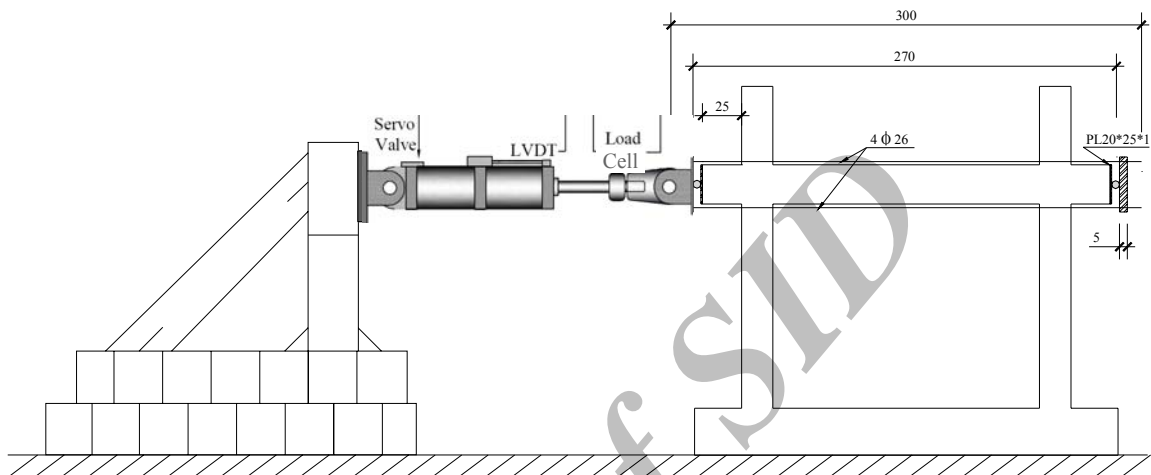

شکل ۳: سیستم بارگذاری.

MATLAB

()

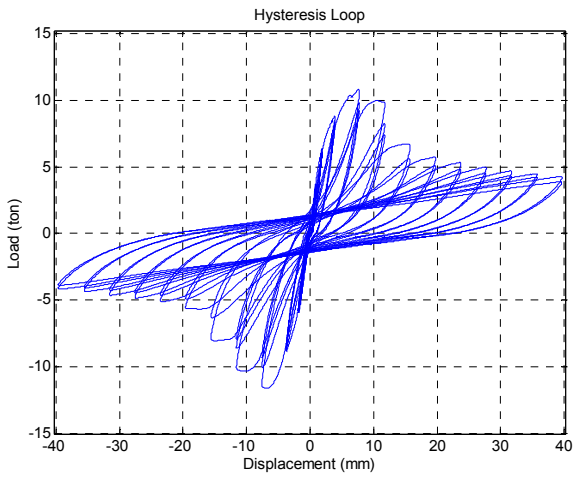

شکل ۶: منحنی رفتاری قاب با میان قاب سفالی.

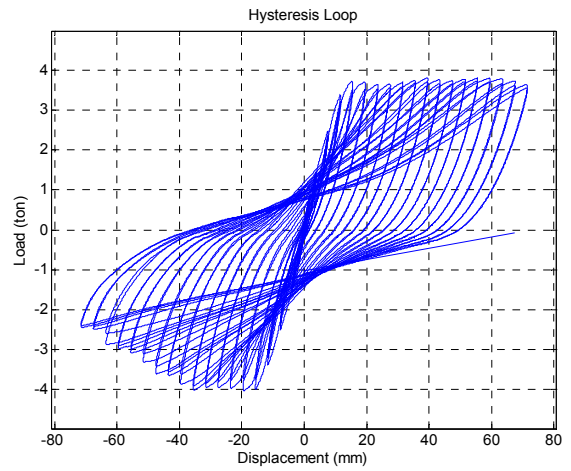

شکل ۴: منحنی رفتاری قاب بدون میان قاب

()

ton

[]

()

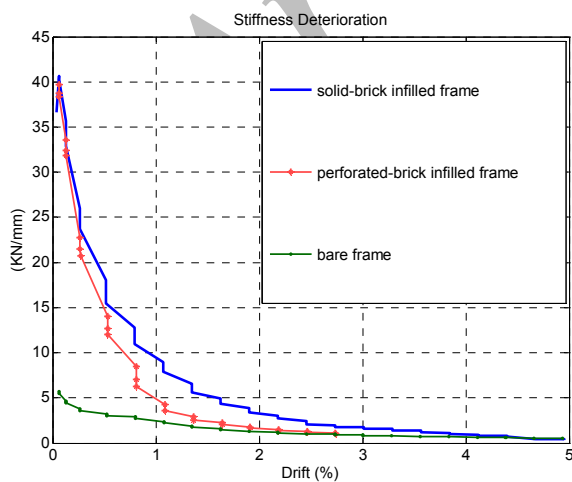

شکل ۷: منحنی تغییرات سختی در نمونه‌های مختلف.

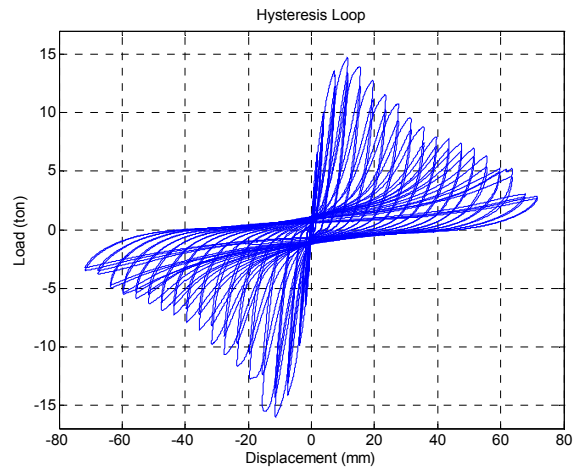

شکل ۵: منحنی رفتاری قاب با میان قاب آجر فشاری.

()

ton

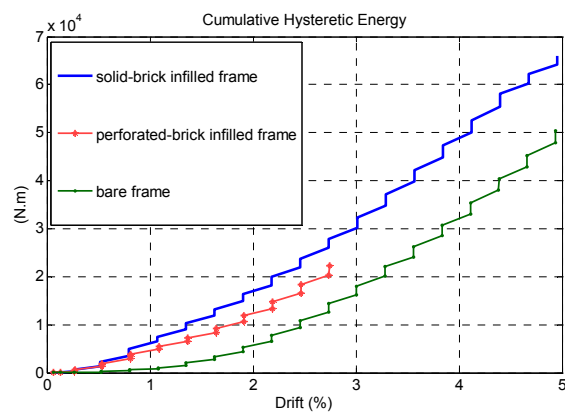

شکل ۸: منحنی انرژی هیستریزیس تجمعی در نمونه‌های مختلف.



شکل ۹: مفاصل پلاستیک ایجاد شده در ی قاب بدون میان قاب، الف) بالای ستون، ب) پایین ستون.

()

()



شکل ۱۱: الگوی ترک خوردگی در قاب دارای میان قاب سفالی.



شکل ۱۰: الگوی ترک خوردگی در قاب دارای میان قاب آجر فشاری.

()

FEMA 356

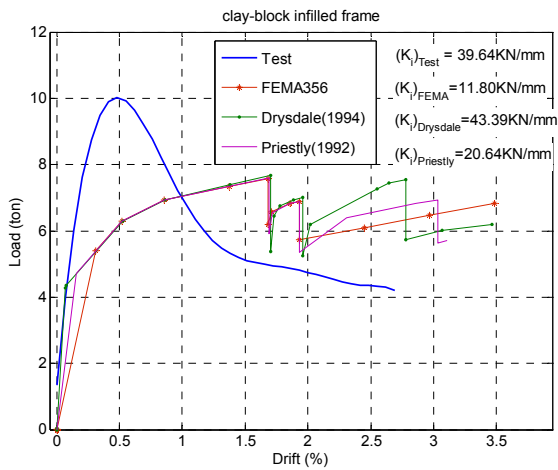

شکل ۱۳: مقایسه نتایج تحلیلی و آزمایشگاهی، میان قاب سفالی.

Drysdale

: [] () Paulay, Priestley
 $a = \frac{1}{4} r_{inf}$ ()

: [] () Drysdale, () Hendry

$$\alpha_h = \frac{\pi}{2} \sqrt{\frac{4E_c I_c h}{E_m t \sin 2\theta'}} \quad ()$$

$$\alpha_L = \pi^4 \sqrt{\frac{4E_c I_b L}{E_m t \sin 2\theta'}} \quad ()$$

$$a = \frac{1}{2} \sqrt{\alpha_h^2 + \alpha_L^2} \quad ()$$

: [] () (FEMA- 356) Mainstone

$$a = 0.254 (\lambda_1 h_{col})^{-0.4} r_{inf} = 0.254 \left(\frac{\pi h}{2\alpha_h} \right)^{-0.4} r_{inf} \quad ()$$

: () ()

:a

:r_{inf}

:α_L, α_h

I_c, I_b

E_c, E_m

:h, L

:t

:θ

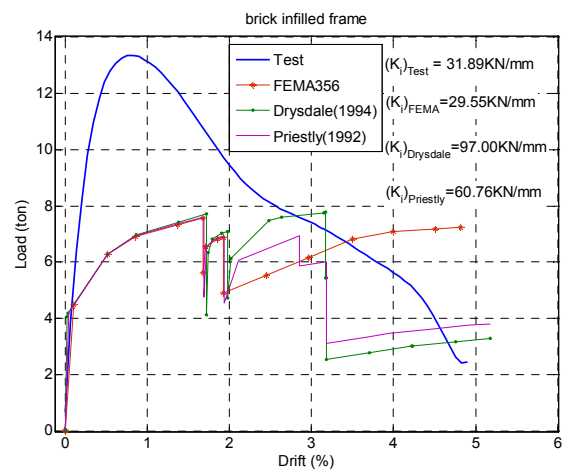

شکل ۱۲: مقایسه نتایج تحلیلی و آزمایشگاهی، میان قاب آجر فشاری.

-
-
- / /
- % /
- /
- SID
- 1 - Nikzad, K. and Moniri, A. H. (1997). "Brick Filled Walls Desirable and Undesirable Effects on Seismic Behaviour of Concrete Frames." *Seismology and Earthquake Engineering Bulletin*, Vol. 2, PP. 14-19.
 - 2 - Polyakov, S. V. (1956). "Masonry in Framed Buildings." (*Godsudarstvenoe Isdatel' stvo Literaturny Po Stroitel'noy Arkhitekture. Moscow, 1956*). Translated by G. L. Cairns in 1963. National Lending Library for Science and Technology, Boston Spa, Yorkshire, U.K.
 - 3 - Stafford-Smith, B. and Carter, C. (1969). "A Method of Analysis for Infill Frames." *Proceedings of the Institution of Civil Engineers*, London, England, Vol. 44, PP. 31-48.
 - 4 - Holmes, M. (1961). "Steel Frames with Brickwork and Concrete Infilling." *Proceedings of the Institution of Civil Engineers*, Vol. 19, PP. 473-478.
 - 5 - Fiorato, A. E., Sozen, M. A. and Gamble, W. L. (1970). "An investigation of the interaction of reinforced concrete frames with masonry filler walls." *Rep. UILU-ENG 70-100, Univ. of Illinois, Urbana-Champaign, Ill.*
 - 6 - Mehrabi, A. B., Shing, P. B., Schuller, M. P. and Noland, J. L. (1996). "Experimental evaluation of masonry infilled RC frames." *Journal of structural engineering*, Vol. 122, No. 3, PP. 228-237.
 - 7 - Klingner, R. E. and Bertero, V. V. (1978). "Earthquake Resistance of Infilled Frames," *Journal of the Structural Division, ASCE*, Vol. 104, No. ST6, PP. 973-989.
 - 8 - Kahn, L. F. and Hanson, R. D. (1979). "Infilled walls for earthquake strengthening." *Journal of the Structural Division, ASCE*, Vol. 105, No. ST4, PP. 283-296.
 - 9 - Bertero, V. and Brokken, S. (1983). "Infills In Seismic Resistant Building." *Journal of the Structural Engineering, ASCE*, Vol. 109, No 6, PP. 1337-1361.
 - 10 - Liauw, T. C. and Kwan, K. H. (1985). "Static and cyclic behaviours of multistory infilled frames with different interface conditions." *Journal of Sound and Vibration*, Vol. 99, Issue 2, PP. 275-283.
 - 11 - Zarnic, R. (1994). "Experimental investigation of the R/C frame infilled by masonry wall." *Journal of engineering modelling*, Vol. 7, No. 1-2, PP. 37-46.
-

- 12 - Zarnic, R. (1994). "Inelastic model of R/C frame with masonry infill-analytical approach." *Journal of Engineering Modeling*, Vol. 7, No. 1-2, PP. 47-54.
- 13 - Al-Chaar, G., Issa, M. and Sweeney, S. (2002). "Behavior of masonry infilled nonductile reinforced concrete frames." *Journal of structural engineering*, Vol. 128, Issue 8, PP. 1055-1063.
- 14 - Colangelo, F. (2004). "Pseudo-dynamic seismic response of infilled RC frames designed for gravity loading." *13th World conference on earthquake engineering*, Vancouver, B.C., Canada, Paper No. 3021.
- 15 - Moghadam, H. (1991). *Seismic design of masonry structures*, International Institute of Earthquake Engineering and Seismology.
- 16 - Moghadam, H. (1994). *Seismic design of masonry structures*, Sharif University Press, Tehran.
- 17 - Motamedi, M. and Behrang, V. (2003). *The influence of masonry infill walls on dynamic behavior of concrete structures*, Islamic Azad University, South Tehran Branch.
- 18 - Tasnimi, A. A. (2004). *Behavior of Brick Walls Recommended by Standard 2800*. Research Report, No. R-404, BHRC publication.
- 19 - Danesh, F. and Behrang, V. (2004). "The influence of masonry infill walls on dynamic behavior of concrete structures." *13th World Conference on Earthquake Engineering*, Vancouver, B.C., Canada, Paper No. 1984.
- 20 - Iranian Code of Practice for Seismic Resistant Design of Buildings. (2005, 1987). Standard No. 2800-05, 1rd & 3rd Edition, No. S-253, BHRC publication.
- 21 - Parsa, F. (2006). *Testing of the performance of masonry infilled R/C frames under cyclic loading*. Msc. Thesis, International Institute of Earthquake Engineering and Seismology.
- 22 - Paulay, T., Priestley M.J.N., (1992). *Seismic Design of Reinforced Concrete and Masonry Buildings*. John Wiley & Sons, Inc.
- 23 - Hendry, A. W. (1990). *Structural masonry*. MacMillan, Ltd. London.
- 24 - Drysdale, R. G., Hamid, A. A. and Baker, L. R. (1994). *Masonry structures: Behaviour and design*. Prentice-Hall, Inc., Englewood Cliffs, N.J.
- 25 - Mainstone, R. J. (1971). "On the Stiffness and Strength of Infilled Frames." *Proc., supplement (IV), Trans. of Instn. of Civ. Engrs.*, London, England.