

فصلنامه مدیریت دولتی

سال اول/ پیش شماره سوم/ زمستان ۱۳۸۹



تاریخ دریافت: ۱۳۸۹/۹/۳۰ تاریخ اصلاح: ۱۳۸۹/۱۰/۲۷ تاریخ پذیرش: ۱۳۹۰/۲/۶

Archive of SID

« »

<sup>۱</sup> عضو هیات علمی دانشگاه علامه طباطبائی afjahi@atu.ac.ir

<sup>۲</sup> کارشناس ارشد مدیریت بازرگانی (گرایش مدیریت تحول) دانشگاه علامه طباطبائی

.. ( )

.. ( )

« »

.....  
/ /

«            »

:

(

(

(            )

«            »

/

/

» :

AFS .«

AFS

( )..

ء

)..

(

.....  
/ /



Archive of SID  
( )..

.....  
/ /

Archive of SID

« »

۵

( )

/ /

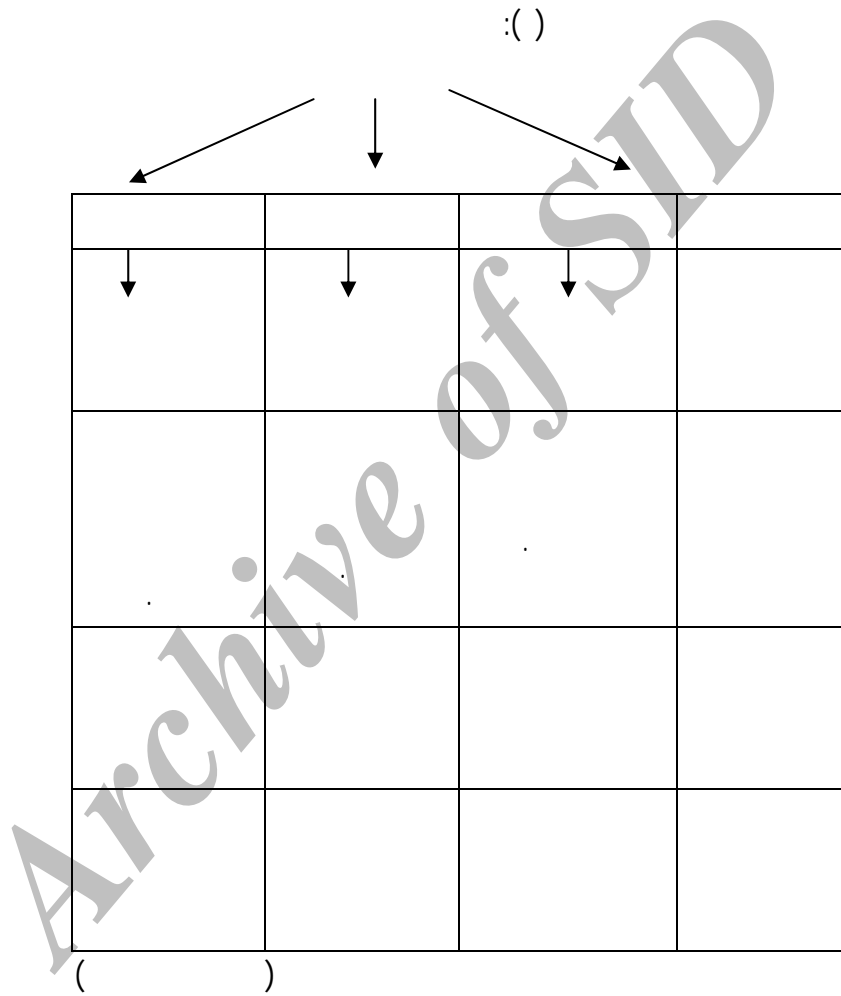



( ) ( )

( ) ( )

Archive of SID

.....  
/ /



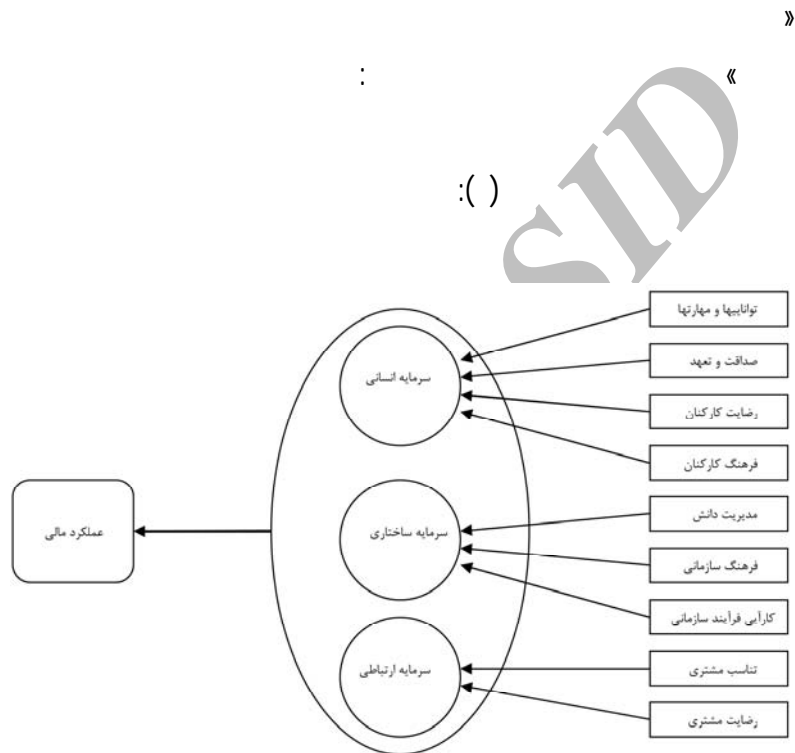

Arc:

(  
(  
(  
(

Archive of SID

« »

.....  
/ /

Archive of SID

.....  
/ /

:( )

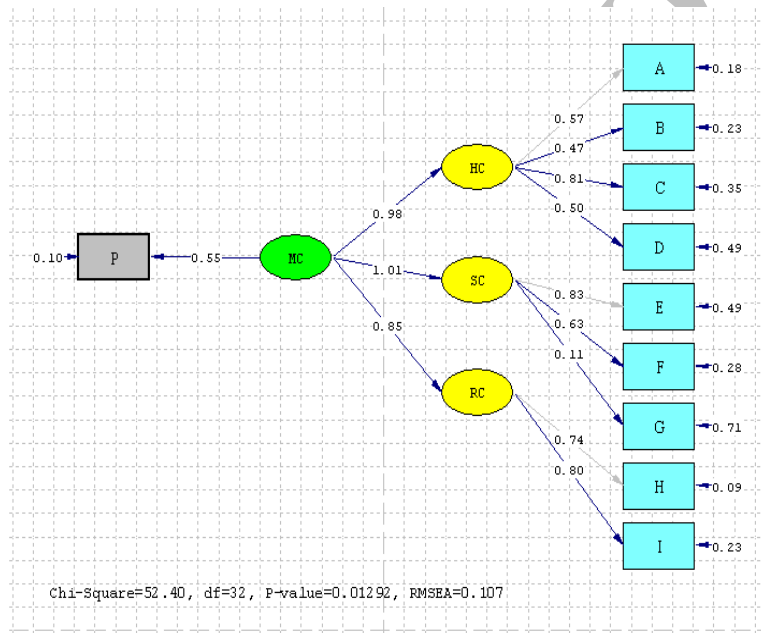

« »

Arch

( / ) .

:()

/	T		
	/	/	
	/	/	
	/	/	

Archive of SID



/ t

:( )

/	T		
/	/	/	
/	/	/	
/	/	/	
/	/	/	
/	/	/	
/	/	/	
/	/	/	
/	/	/	
/	/	/	

/

/ t

/ /

Archive of SID

/ t

/

/ t

( / ) .

( / ) .

( / ) .

( / )

( / ) .

( / ) .

« »

/ /

( )

)

(

( )

Archive of SID

.....  
/ /

( )

( )

Archive of SID

.....  
/ /

Archive of SID

( )

« »

.....  
/ /

Archive of SID

✓

.....  
/ /

Archive of SID ✓  
✓  
✓  
✓

.....  
/ /



Archive of SID ✓  
( ✓  
) ✓  
✓  
✓  
✓  
✓  
✓

.....  
/ /

( / )

( )

( )

✓

✓

✓

✓

✓

✓

(

✓

Archive of SID

.....  
/ /

✓

✓

✓

- 1) Nasser, T. (1996) *Knowledge Leverage: The ultimate advantage*. Retrieved from:  
<http://www.brint.com/papers/submit/nasser.htm>
- 2) Bontis, N., Keow, W.C.C. and Richardson, S. (2000) Intellectual capital and business performance in Malaysian industries. *Journal of Intellectual Capital*, 1, 89-90.
- 3) Silverstone, S. (1999) *what's the key to implementing knowledge management?* Retrieved from:  
<http://www.strassmann.com/pubs/kmmag-0499.html>
- 4) Tayles, M. Bramley, A., Adshead, N. and Farr, J. (2002) Dealing the management of intellectual capital: the potential role of strategic management accounting. *Accounting, Auditing & Accountability Journal*, 15, 258-260.
- 5) Ortiz, M.. (2007) *Intellectual capital valuation considering the context*. Retrieved from:  
<http://www.icapitali.org>
- 6) Hamel, G. and Prahalad, C.K. (1996) competing in the new economy: managing out of bounds. *Strategic Management Journal*, 17, 238.
- 7) Bontis, N. (1998) Intellectual capital: an exploratory study that develops measures and models. *Management Decision*, 36, 63-70.
- 8) Nelson, R.R. and Winter, S.G. (1982) An evolutionary theory of economic change. *Belknap Press*, Cambridge, MA.
- 9) Roos, J., Roos, G., Edvinsson, L. and Dragonetti, N.C. (1997) *Intellectual Capital: Navigating in the New Business Landscape*. New York: Macmillan.

/

/

- 10) Hudson, W. (1993) Intellectual capital: how to build it, enhance it, use it. **John Wiley & Sons**, New York, NY.
- 11) Cohen, S. and Kaimenakis, N. (2007) Intellectual capital and corporate performance in knowledge-intensive SMEs. **The Learning Organization**, 14, 241-262.
- 12) Marr, B. Schiuma, G. and Neely, A. (2004) the dynamics of value creation: mapping your intellectual performance drivers. **Journal of Intellectual Capital**, 5, 316.

Archive of SID