

()

طراحی و ساخت دستگاه تداخل سنج فابری - پروی روبشی

Archive of SID

Design and Construction of a Scanning Fabry-Perot Interferometer

H. R. Fallah*, A. Kiasatpour* and B. Faghieh Imani**

***Department of Physics, University of Isfahan**

****M. S. Student of Physics, University of Isfahan**

Abstract

Fabry-Perot interferometer has classically been used for defining fine structures of spectral lines. Today it is also used in modern technology such as ultra stable lasers because of its very high resolving power.

In this paper Fabry-perot interferometer is briefly discussed and a scanning fabry-perot interferometer is designed and constructed. Also, its construction and operation is explained. Fringes of He-Ne laser, Sodium and Hg sources are formed and studied by this scanning fabry-perot interferometer. Using this instrument, we have conducted some tests and have tried to measure the separation between two sodium lines.

Keywords: Interferometry, Fabry-perot interferometer, Scanning interferometer, Spec

l...

(.)

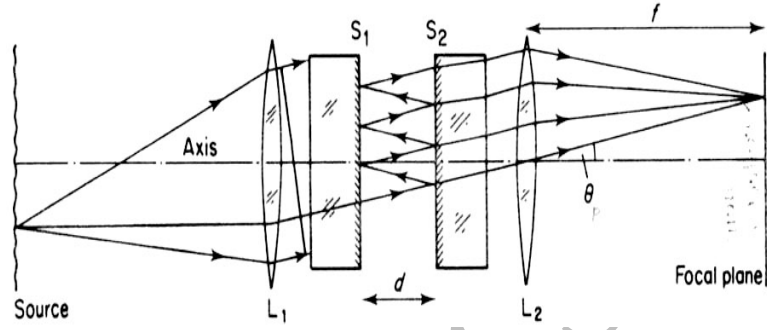

$$\rho = \left(\frac{1 - R}{1 + R} \right)^2$$

$$\frac{T^2}{(1 - R)^2 \{1 + [fR / (1 - R)^2] \sin^2 \pi \delta / \lambda\}}$$

R T

$$\frac{fR}{(1 - R)^2}$$

/

()

()

(.)

BKv

()



:

$\lambda/$

$\lambda/$

Architect of SID

l...

A

B

Archive of SID

/

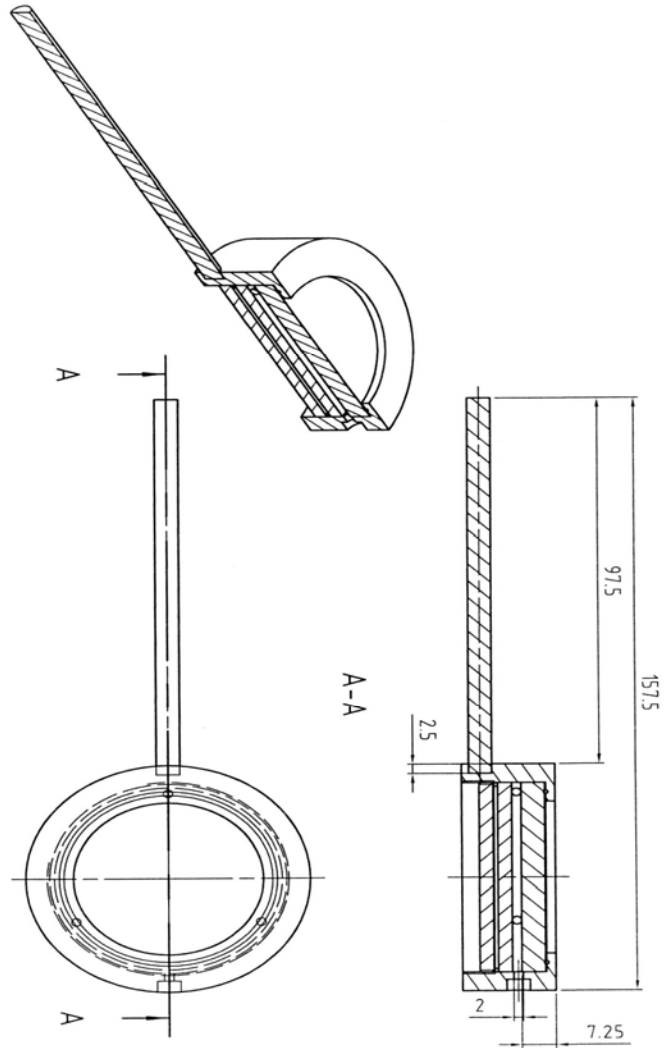

(A)

l...

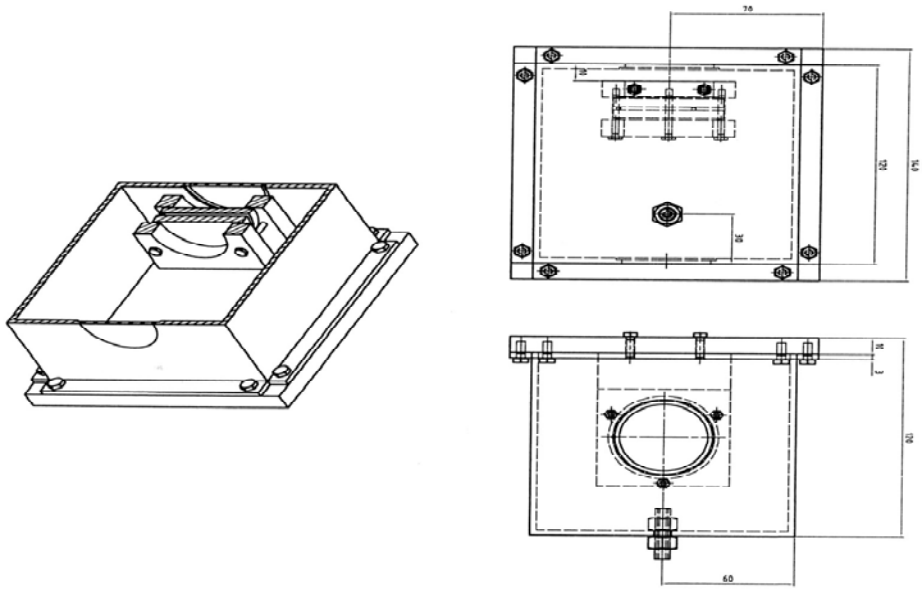

(B)

A

A

A

Archive 01

/

B

B

A

B

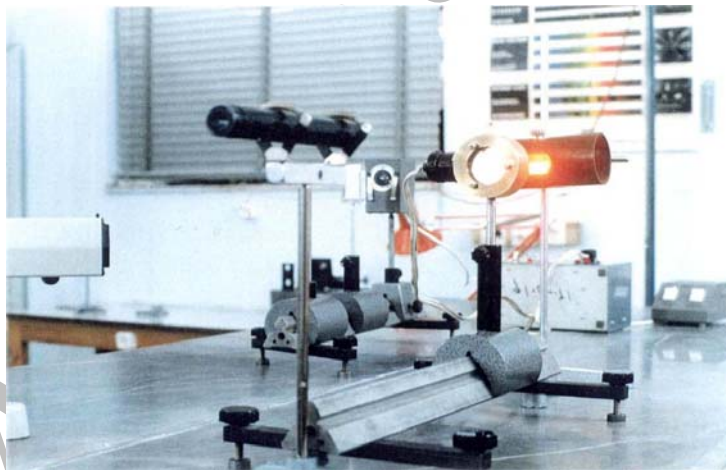

...

Archive of SID

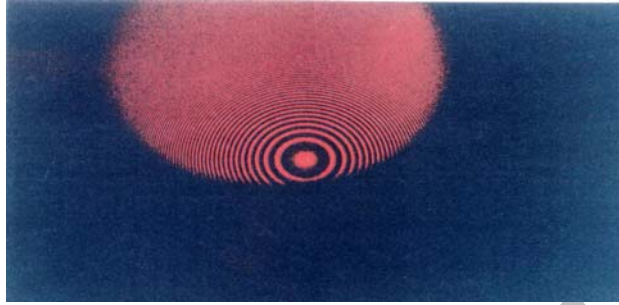

()



()

d) F.P. f m (n

: () λ

$$nd \cos \theta = m \lambda$$

: D θ

$$\theta = D / f$$

θ

$\cos \theta$

:

$$d(D^\vee) / dm = \vee \lambda f^\vee / nd$$

l...

) d (n = ,) n m D
λ f (

()

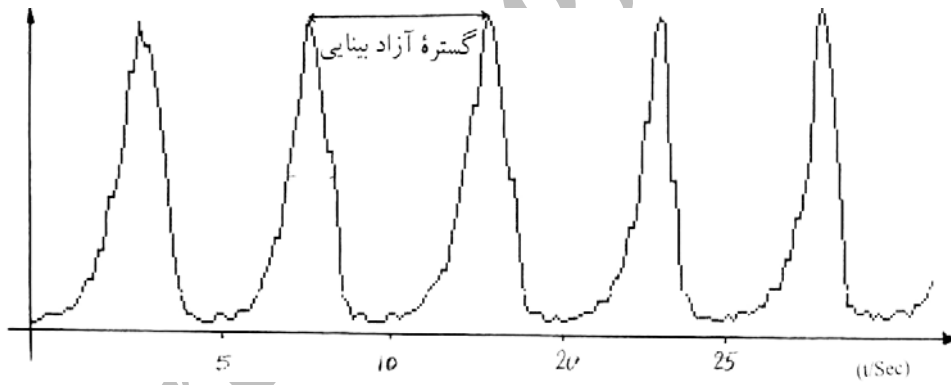

B

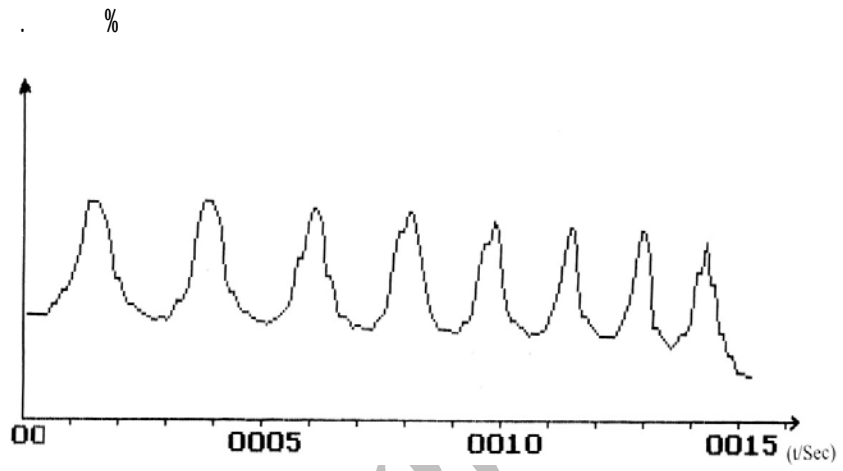

Archive 03

(%)

(%)

(

)

/...

- . Hernandez, G. (). “Fabry–Perot Interferometers”, Cambridge University Press.
- . Dae-Hyun Kim, Joong-Wan Park, Hyun-Kyu Kang, Chang-Sun Hong and Chun-Gon Kim (). “Measuring dynamic strain of structures using a gold-deposited extrinsic Fabry–Perot, interferometer”. *Smart Mater. Struct.* Vol. p. – .
- . Do-Hyung Kim, Jae-Hung Han, Seung-Man Yang, Dae-Hyun Kim, In Lee, Chun-Gon Kim and Chang-Sun Hong (). “Optimal vibration control of a plate using optical fiber sensor and PZT actuator”. *Smart Mater. Struct.* Vol. p. – .
- . H. C. Seat, EOuisse, Emorteau and VM’etivier, (), “Vibration–displacement measurements based on a polarimetric extrinsic fibre Fabry–Perot interferometer”, *Meas. Sci. Technol.* Vol. p. – .
- . Hyung-Joon Bang, Chang-Sun Hong, Hyun-Kyu Kang and Chun-Gon Kim, (), “Simultaneous measurement of strain, temperature and vibration frequency using a fibre optic sensor”, *Meas. Sci. Technol.* Vol. p. – .
- . Born, M., and Wolf, E.(). “Principles of Optics”. Pergamon Press, Oxford.

Archive of SID