

Archive of SID

(alidousti@irandoc.ac.ir)
(m.nazari@sheffield.ac.uk)

.۱
.۲

»
« » «
()

Archive of SID

/ ...

(Scammell ,)

(Abdoulaye and Majid ; Bardley , - ; Kaku , - ;
McMurdo)

(Oppenheim ;

.Foster)

(Brophy ;

Chowdhury and Chowdhury , -)

.(Akeroyd)

(Chen)

.(Bruijnzeels)

\. virtual or electronic libraries
Ȳ. hybrid

/

« »

:

« »

(Wilson and Wilson ,)

(Ammer and Ammer)

(Checkland , ;)

(McLeod)

« »

/ ...

(Marion

() . ,)

(Anderws

.)

.(Jauch and Glueck ,)

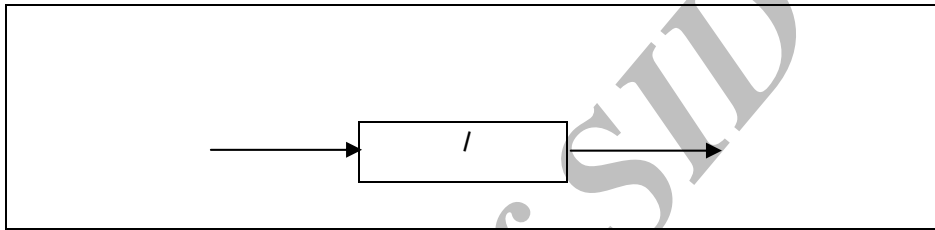

۳

() .(McLeod ,)

- ۱. open system
- ۲. feedback loop
- ۳. closed-loop system

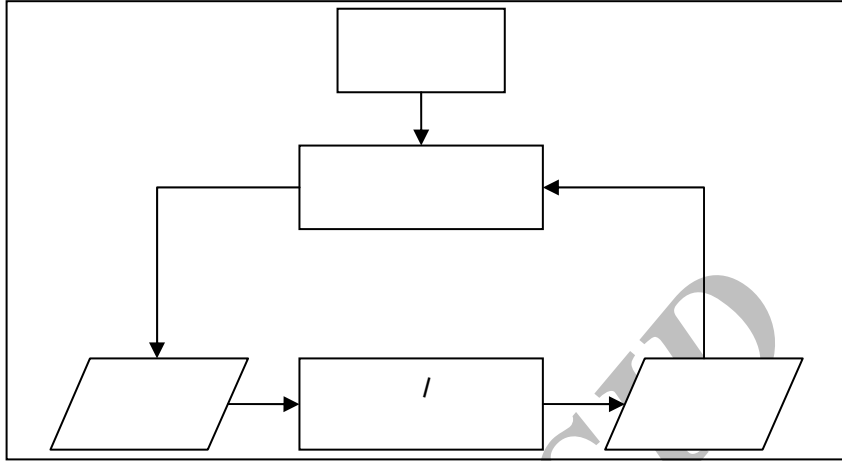

(Mcleod ,)

Archive of SID

/...

Archive of SID

(Child and Faulkner ,)

.(Kreithner and Kinicki)

.(Hofstede)

/

Archive of SID

()

()	()
()	()

۱. Strength, Weaknesses, Opportunities, an Threats: SWOT

l...

(Pettinger , - ; Corral , ; Pearce & Robinson , -)

« ».

.(Bryson ,)

(Pettinger , - ; Corral , ; Pearce & Robinson , -
:Λ•; Jauck & Glueck ۱۹۸)

۱. Social, Technological, Economical, and Political: STEP

Archive of SID

- ١. classification
- ٢. exhaustive

l...

(Bailey , , , , -)

(Bailey ,)

(Hodge and

.Anthony ,)

()

().

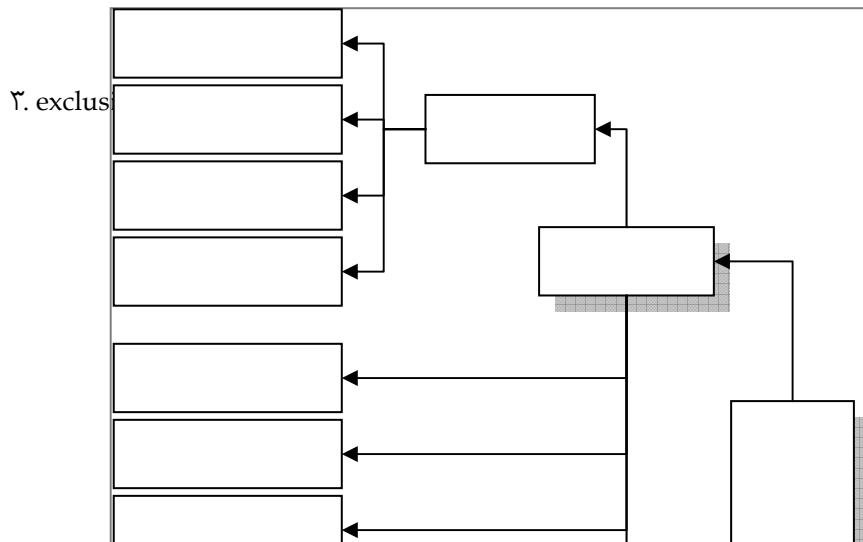

/

Archive of SID

.(DeLone and McLean)

l...

Archive of SID

Archive of SID

/...



...

Archive of SID

...

Archive of SID

1...



Archive of SID

/

Archive of SID

l...

Archive of SID

Archive of SID

l...



Archive of SID

Archive of SID



l...



ive of SID
()

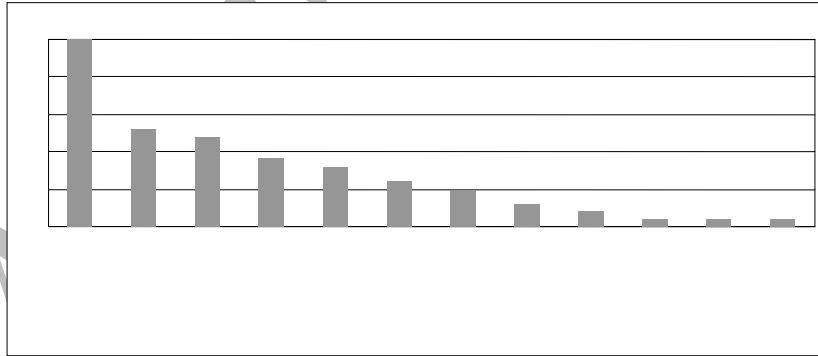

/

	*()		()
	()		
	()		
	()		
	()		
	()		
	()		
	()		
	()		
	()		
	()		
	()		

*

Archive

/...

Abdoulaye, Kaba, and Shaheen Majid. ۲۰۰۰. Use of the Internet for reference services in Malaysian academic libraries. *Online Information Review* ۲۴ (۵): ۲۸۱-۲۸۸.

Akeroyd, John. ۲۰۰۱. The management of change in electronic libraries. *IFLA Journal* ۲۷ (۲): ۷۰-۷۲.

American Library Association. ۱۹۶۷. *Interlibrary Cooperation*. Chicago: American Library Association. Quoted in: Kumar ۱۹۹۱.

Ammer, Christine, and Dean S. Ammer. ۱۹۸۴. *Dictionary of Business and Economics*. ۲nd ed. US: The Free Press.

Andrews, Kenneth R. ۱۹۹۹. The concept of corporate strategy. In *The Strategy Process*, edited by Henry Mintzberg, James Brian Quinn, and Sumantra Ghoshal. London: Prentice-Hall.

Bardly, Phil. ۱۹۹۷. *Going online, CD-ROM and the Internet*. London: Aslib.

Bonk, Sharon C. ۱۹۸۹. Will resource sharing up to its potential. *Library Acquisitions: Practice & Theory* ۱۳: ۱۷۱-۱۷۵.

Bouazza, Abdelmajid. ۱۹۸۶. Resource sharing among libraries in developing countries: The gulf between hope and reality. *International library Review* ۱۸: ۳۷۳-۳۸۷.

Brophy, Peter. ۲۰۰۰. Towards a generic model of information and library services in the information age. *Journal of Documentation* ۵۶ (۳): ۱۶۱-۱۸۴.

Bryson, John M. ۱۹۹۵. *Strategic planning for Public and Nonprofit Organizations*. San Francisco: Jossey-Bass.

Bailey, Kenneth D. ۱۹۹۴. *Typologies and taxonomies: An introduction to classification techniques*. Thousand Oaks, CA: Sage.

Bruijnzeels, Rob. ۲۰۰۲. *Bibliotheken ۲۰۴۰: Libraries ۲۰۴۰ - The future in progress*. In *The proceeding of ۶۸th IFLA Council and General Conference*. Glasgow: IFLA.

Carhart Jr., Forrest F. ۱۹۸۳. Library co-operation brings benefits: A pattern for action". *Unesco Journal of Information Science, Librarianship and Archives Administration* ۵ (۴): ۲۳۱-۲۳۶.

Checkland, Peter. ۱۹۸۹. Reprint. *System thinking, systems approach*. New York: John Wiley. ۱۹۸۱.

Checkland, Peter. ۱۹۹۶. Systems. In *International Encyclopedia of Business & management*, edited by Malcolm Warner. London: Routledge.

Chen, Ya-ning. ۲۰۰۲. Application and development of electronic books in and e-Gutenberg age. *Online Information Review* ۲۷ (۱). www.emeraldinsight.com (۲۰ Aug. ۲۰۰۴).

Child, John, and David Faulkner. ۱۹۹۸. *Strategies of Co-operation*. Oxford: University Press.

Chowdhury, Gobinda. G., and Sudatta Chowdhury. ۲۰۰۳. *Introducing to digital libraries*. London: Facet.

/...

Cornish, Graham P. ۱۹۸۹. Interlending in the Caribbean. *International Library Review* ۲۱: ۲۴۹-۲۶۱.

Corrall, Sheila. ۱۹۹۵. *Strategic Planning for Library and Information Services*. London: Aslib.

Dannelly, Gay N. ۱۹۹۵. Resource sharing in the electronic era: Potentials and paradoxes. *Library Trends* ۲۲ (۲): ۶۶۳-۶۷۸.

DeLone, William H., and Ephraim R. McLean. ۱۹۹۲. Information systems success: The quest for the dependent variable. *Information Systems Research* ۳ (۱): ۶۰-۹۵.

Dominguez, P. B. and L. Swindler. ۱۹۹۳. Cooperative Collection Development at the Research Triangle University Libraries: A Model for the Nation. *College & Research Libraries* ۵۳: ۲۷۹-۲۹۶.

Dougherty, Richard M., and Carol Hughes. ۱۹۹۰. A historical perspective and a vision for the future. *Advances in Library Resource Sharing* ۱: ۱-۲۱.

Dowd, Sheila T. ۱۹۹۰. Library cooperation: Methods, models to aid information access". *Journal of Library Administration* ۱۲ (۲): ۶۳-۸۱.

Downs, Robert B. ۱۹۴۵. American library cooperation in review. *College & Research Libraries* ۶: ۴۰۷-۴۱۵. Quoted in: Weber ۱۹۷۶.

Fetterman, John. ۱۹۷۴. Resource sharing in libraries - Why? In *Resource sharing in libraries*, edited by Allen Kent. New York: Marcel Dekker.

Hightower, Chrisly, and George Soete. ۱۹۹۵. The consortium as learning organization: Twelve steps to success in collaborative collections project. *The Journal of Academic Librarianship*.

Hodge, B.J., and William P. Anthony. ۱۹۷۸. *Organization Theory*. Boston: Allyn and Bacon.

Hofstede, Geert. ۱۹۹۶. Organization culture. In *International Encyclopedia of Business & Management*, edited by M. Malcolm. London: Routledge.

Horton Jr., Forest Woody. ۱۹۹۴. Sharing information for competitive advantage. In *New Worlds in Information and Documentation: Proceedings of the Forty-sixth FID Conference and Congress*, edited by J.R. Alvarez-Ossorio and B. G. Goedegebuure. The Netherlands: Elsevier.

Foster, William. ۲۰۰۰. Developments in technical services: Cultural change and organizational management In Achieving cultural change in networked libraries, edited by B. J. Reid and W. Foster. England: Gower.

Jauch, Lawrence R., and William F. Glueck. ۱۹۷۸. Business Policy and Strategic Management. ۵th ed. New York: McGraw-Hill.

Kaku, Michio. ۱۹۹۸. Visions: How science will revolutionize the Twenty-First century. Oxford: Oxford University Press.

Keenan, Stella. ۱۹۹۱. International cooperation - Pain or gain? In Handbook of Library Cooperation, edited by Alan F. MacDougall and Ray Prytherch. UK: Gower.

Kent, Allen. ۱۹۷۸. Resource sharing in libraries. In Encyclopedia of Library and Information Science. Vol. ۲۵, edited by Allen Kent, Harold Lancour, and Jay E. Daily. New York: Marcel Dekker.

Kreithner, Bob, and Angelo Kinicki. ۱۹۹۵. Organizational Behavior. US: Addison Wesley Publication.

Kumar, Krishan. ۱۹۹۱. Reprint. Library organization. New Delhi: Vikas Publishing House PVT LTD, ۱۹۸۷.

Lynden, Fredrick C. ۱۹۹۸. Resource sharing: Making possible the transition from paper to electronic information. In The networking information society. The Netherland: FID: ۵۸۰ - ۵۸۶.

Marion, Russ. ۱۹۹۹. The Edge of Organization: Chaos and Complexity Theories of Formal Social Systems. California: SAGE.

Mattessich, Paul W., and Barbara R. Monsey. ۱۹۹۲. Collaboration: What Makes it Work. Minnesota: Amherst H. Wilder Foundation.

McLeod Jr, Raymond. ۱۹۹۵. Management Information systems. New Jersey: Prentice-Hall.

McMurdo, George. ۱۹۹۷. The Internit. In Handbook of special librarianship and information work, edited by Alison Scammell. London: Aslib.

Miller, Robert C. ۱۹۹۲. Resource sharing: A personal perspective. Advances in Library Resource Sharing ۳: ۱۰-۱۶.

Oppenheim, Charles. ۱۹۹۷. Towards the electronic library? In Handbook of special librarianship and information work, edited by Alison Scammell. London: Aslib.

/...

Pearce, John A., and Richard B. Robinson Jr. ۱۹۷۸. Strategic management: Strategy formulation and Implementation. Illinois: Irwin.

Pettinger, Richard. ۱۹۹۶. Introduction to Corporate Strategy. Grait Britain: Macmillan.

Scammell, Alison. ۱۹۹۷. The role of the special librarian in the electronic era. In Handbook of special librarianship and information work, edited by Alison Scammell. London: Aslib.

Sewell, Philip H. ۱۹۸۱. Resource sharing: Co-operation and co-ordination in library and information services. London: Ander Deutsch.

Stephens, Andy, and Stuart Ede. ۱۹۹۱. The role of the British Library in Cooperation. In Handbook of library cooperation, edited by Alan F. MacDougall and Ray Prytherch. UK: Gower. ۹۸-۱۱۷.

Tocatlin, Jacques. ۱۹۹۴. A view of past issues and experiences in international cooperation. In Proceedings of the Forty-Sixth FID Conference and Congress. New York: Elsevier: ۴-۱۴.

Weber, David. ۱۹۷۶. A century of cooperative programs among academic libraries. College & Research Libraries (May): ۲۰۵-۲۲۱.

Wilson, Ira G., and Marthann E. Wilson. ۱۹۷۱. Management, Innovation & System Design. Princeton: Auerbach.

Wilson@sheffield.ac.uk. ۲۰۰۰: [SMTP:t.d.wilson@sheffield.ac.uk]

Archive.org