

Experimental and numerical investigations about water entry of a symmetrical wedge**Mooud Nikfarjam¹, Omar Bin Yaakob², Mohammad Saeed Seif³, Jaswar Koto⁴, Ali Aref⁵**¹ PHD Candidate, Universiti teknologi Malaysia, nmooud2@live.utm.my² Professor of marine technology centre, Universiti Teknologi Malaysia, Omar@fkm.utm.my³ Professor of Centre of excellence in hydrodynamic & dynamic of marine vehicles, Sharif University of Technology, Seif@sharif.edu⁴ Professor of Department of Aeronautics, Automotive and Ocean Engineering, Universiti Teknologi Malaysia, Jaswar@mail.fkm.utm.my⁵ MSC Student, Sharif University of Technology, Aliaref@outlook.com**Abstract**

In current study, numerical and experimental investigations about water entry problem were conducted for a symmetrical wedge. The water entry problem for different geometries is one of the classical methods for determination of pressure distribution and loads around the hull of marine vehicles. These data can be used for optimum structural design of vessels particularly for high-speed crafts, which are very sensitive about the weight. In addition, the quantity of load can be considered in the equation of motion for analyzing the seakeeping performance of such vessels.

In this research, the numerical analysis of free falling wedge with 30° deadrise with constant weight was done and for validation of results, it was followed by experimental tests. The outputs of this study consist of some graphs for comparison of trends for pressures respect to impact time, which can be used for signification of loads on hulls during the water entry phase.

Keywords: Water entry, Wedge, Pressure distribution**Introduction**

In recent years, the application of high-speed crafts has expanded in different fields and despite these applications relevant topics such as loading estimation, structural design, motion control and etc. became important for researchers more than past.

High-speed crafts encounter wide range of impact loads during their lifetime because of jumping through the waves and coming back to water surface in various sea-states. So the water entry problem can be used as a basic solution for estimation of loads on their hull. Besides that, the slamming phenomenon, which is considered as a limitation for structural design, can be predicted in this way.

Water entry problem was known as a useful way for prediction of pressure on the hull of seaplanes by Von-Karman [1] in 1929 and he conducted some theoretical models for calculation of maximum pressure for that vessels. After him, in 1932 Wagner proposed an analytical method for modeling of water entry problem with some modifications on Von-Karman's model [2]. Dobrovolskaya [3] in 1969 with an analytical method based on similarity solution studied about falling of a wedge into water with constant speed. In 1988 Payne [4], Korobkin and Pokhnachov [5] established some studies about impact of water on rigid bodies.

In recent years, researchers followed up the process of water entry evaluation by different numerical methods. For example, Zhao and Faltinsen [6] worked on Wagner's theory through conformal mapping and conducted an approximation in 2D cases. This strategy was continued by Mei [7] in 1999. In new studies some additional effects during impact problem, was considered such as hydroelasticity. For example Zamani-rad and Seif [8] was done simulation of hull water impact based on numerical methods for study of hydroelastic effect during the slamming process of wedge-shaped bodies.

Besides these theoretical investigations, some experimental developments had done on water entry problem of different geometries. In 1950, Bisplinghoff and Doherty [9] had done experimental tests on wedges and proposed a theory for prediction of free surface during water entry. In 1970, Chuang [10] started experimental tests on wedges with different deadrise angles and measured maximum pressure on them. Chuang also in 1967 [11] studied about the impact of plane's surface on still water and evaluated the effect of trapped air between water surface and hull in small angles. Ochi and Bonilla in 1970 [12] and Chuang in 1973 [13] studied about penetration speed and water impact on complex geometries such as boat's hull. Greenhow and Lin [14] in 1983 continued the experiments for some different wedges and focused on water current around the hull.

In 1994, Lin and Ho [15] had done some experimental tests for impact of 2-D wedges in different heights and compared the results with numerical analysis based on boundary element method. They showed that the maximum impact pressure in shallow water is greater than similar condition in deep water. In 1997, Zhao [16] proposed two methods for water entry analyzing with non-linear simulation of Laplas equation and analytical solution of Wagner and validated the results with experimental tests of 30° wedge with results of pressure coefficient, slamming force, impact velocity and water level condition. The studies of Ming-Chung Lin and Li-Der Shieh in 1997 [17] prepared experimental results on round hull pressure distribution during water entry. Study about impact of surface plane and water level was continued by Engle and Lewis [18] in 2003 and they compared the results of numerical and

experimental methods for maximum pressure due to water impact for symmetrical wedge in different initial speed. These studies showed the validity area and accuracy of various methods. In 2004 Faltinsen [19] studied about some important application of water entry problem such as wetdeck slamming, green water, tank sloshing and etc. Also in this year Wu [20] conducted some experimental tests on wedges with 20 and 45 degree deadrise and compared the results with numerical data of complex method of analytical and BEM solutions. Yettou et al in 2005 [21] had done some experimental tests on different wedges for calculation of pressure coefficient with different weights and heights. They showed that deadrise angle has more importance effect on pressure in comparison with weight and drop height. In 2010, Sayeed et al [22] evaluated of slamming force on wedge with 10° deadrise and their results showed good correlation with Chaung's data. Javaherian et al [23] had done parametric experimental study about pressure distribution of pressure during water entry for 3 deadrise angle which dropped into water from various heights. They proposed some graphs for pressure coefficient respect to time and they compared the data with other references.

Figure 1 shows the effective parameters such as peak pressure, position of it and the schematic view of pressure profile as important items in water entry process.

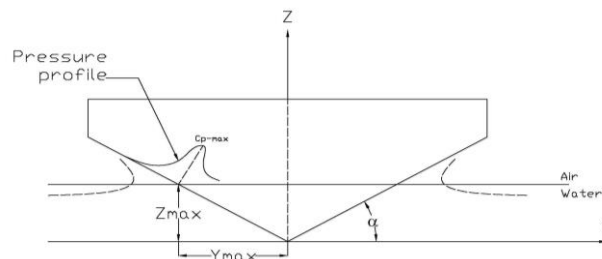

Figure 1: Slamming pressure's parameters during water entry

The time variation in short period is one of the problems for solving the water entry process and measurement of pressure need accurate numerical simulation and special experimental facilities. In real condition, the rapid transient pressure changes cause some difficulties in process conditions.

In this paper for a symmetric wedge with 30° deadrise and constant weight, the pressure distribution was discussed through numerical and experimental analyzing. In addition, a configuration of experimental test setup which designed for testing of hydrodynamic loads on basic geometries during water entry was explained that can be used in future researches of similar problems. Based on the results, estimation for hydrodynamic loads on 2-D sections can be proposed which may use in design of high-speed crafts and similar structures.

Numerical analysis

After modeling of geometry according to Figure 2, numerical analysis started when the wedges contact the water surface. The weight was considered about 38 kg. For meshing of analysis domain, the 2D structural mesh was used and the upper border of model was considered as atmospheric pressure. The surface of wedge was assumed as a no slip area.

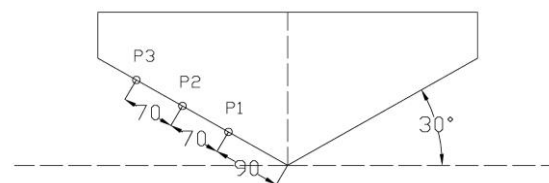

Figure 2: General view of model and position of pressure sensors (Dimensions in mm.)

Figure 3 shows the simulation of water entry and the spray at the moment of impact can be clearly observed.



Figure 3: Free surface of liquid for impact of wedge during water entry

Experimental tests

The test set-up configuration is shown in Figure 4. A vertical guide is fixed to the wall of channel for both side of wedge and it can move freely with two sliding guides. The water level was considered at 1 m and maximum height of drop was set to 1-1.3 m. The wedge was made from the fiberglass material.

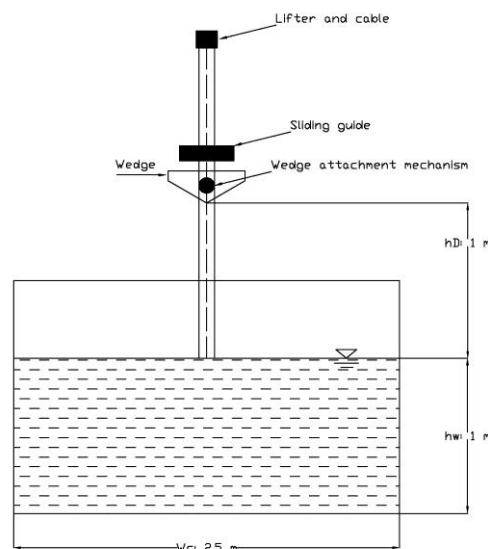

Figure 4: Illustration of test set-up's main elements and basic dimensions

The length of channel is 25 m and the width and height of it are 2.5 m and 1.5 m respectively. It was located in marine laboratory of mechanical faculty of Sharif University of Technology and general view of test set-up is shown in Figure 5.



Figure 5: General view of test set-up after installation in channel

Three pressure transducers were installed on one side of wedge according to Figure 2. These sensors can measure the pressure up to 1000 psi with accuracy range of 0.001 psi. In addition, a suitable data acquisition system with three channels was constructed for receiving of data from sensors. Sensors have the capability of measuring the 25000 data in second. The tests were done for a weight of 38 kg which was adjusted with extra weights on the it. Test's parameters are shown in Table 1.

Table 1: Test's parameters

| Deadrise (Degree) | Weight (Kg) | Drop height (m) |
|-------------------|-------------|-----------------|
| 30 | 38 | 0.2 |

The wedge was dropped vertically under effect of its weight and each test was repeated five times. The average of results was used as final data. When the wedge contacts the water surface, sensors can register the pressure's changes over time and with having the data the pressure coefficient can be calculated with following equation:

$$C_p = \frac{P}{\frac{1}{2}\rho V^2} \quad (1)$$

Results and discussions

The pressure at defined points of wedge during water entry is shown in Figure 6. It can be seen that the pressure for all points has an increasing trend until reaching a peak and after it decreases over the time. Also the points which was installed in higher heights encounter smaller peak pressure because of damping effect of water.

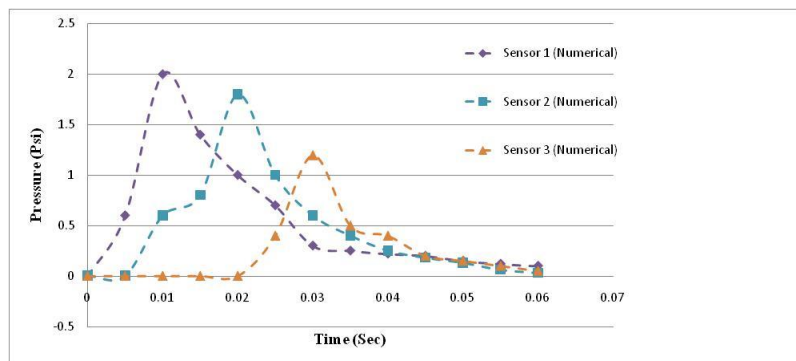

Figure 6: Pressure distribution in comparison the time during the numerical analysis for different points

Figure 7 shows the similar graphs from experimental test's data and equivalent trend can be seen in different position of measurement.

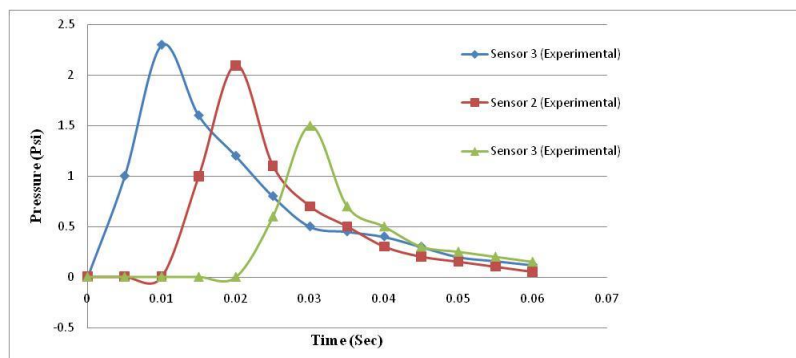

Figure 7: Pressure distribution in comparison the time during the experimental tests for different points

Figures 8, 9 and 10 depict a comparison for results of each point with numerical simulation and experimental results, respectively. It was clearly observed that the trend of results for both approaches are similar but there were some differences between them, which can be explained due to variations of modeling methods and assumptions.

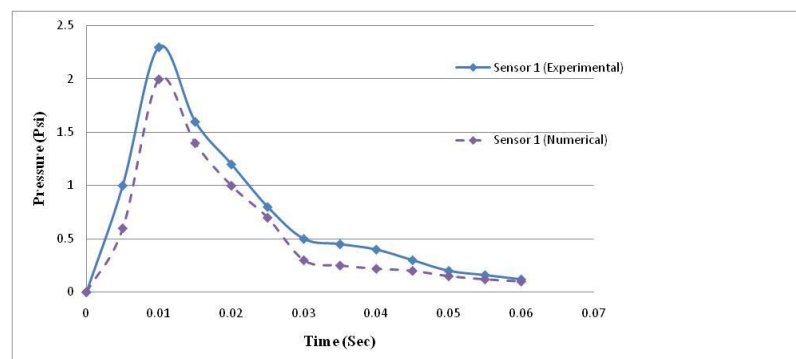

Figure 8: Comparison of results of numerical simulation and experimental test for pressure sensor no. 1

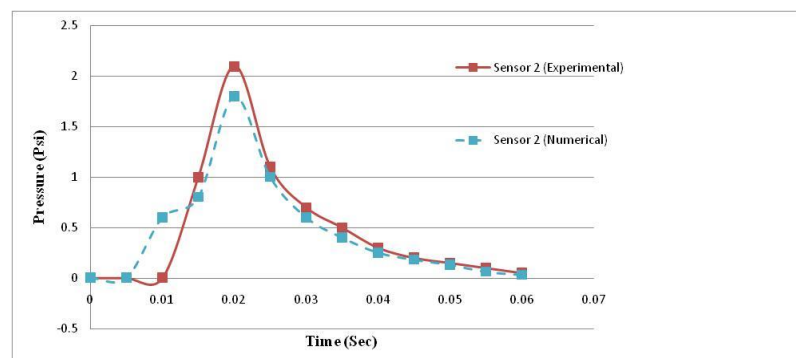

Figure 9: Comparison of results of numerical simulation and experimental test for pressure sensor no. 2

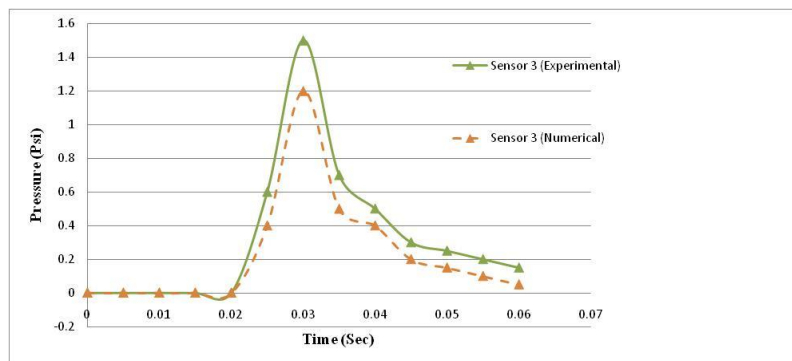

Figure 10: Comparison of results of numerical simulation and experimental test for pressure sensor no. 3

For future reference, these graphs can be used for deriving some parametric analysis for calculation of C_p and estimation of pressure for various points.

Conclusions

In this paper, Numerical analyses of water entry problem for a wedge were conducted by commercial software “Ansys” and followed by experimental tests with similar conditions. The results from this study can be used in the design phase of marine vehicles and other structures.

The results are evident of similarity of data by two methods. However, it can be seen that numerical method’s output gives underestimate values in comparison with the experimental results which should be considered in design phase. In addition, the correction factor of data for numerical analysis can be found as a useful parameter for future researches. In a nutshell, the selected software has been proven efficient for modeling water entry problem for wedge water entry subjects. This preliminary study will be followed up by future tests which will be carried out in the near future.

Acknowledgment

The authors would like to convey a great appreciation to Marine Laboratory of Mechanical Faculty of Sharif University of Technology for supporting the experimental test's facilities.

List of Symbols

| | |
|-------|--------------------------|
| h_w | Height of water (m) |
| h_c | Width of channel (m) |
| h_D | Drop height (m) |
| C_p | Pressure coefficient (-) |
| P | Pressure (Kpa) |
| V | Velocity (m/sec) |

Greek symbols

| | |
|----------|------------------------------------|
| α | Deadrise angle (Degree) |
| ρ | Water density (Kg/m ³) |

References

- [1] Von Karman, T., (1929), The impact on seaplane floats during landing, National Advisory Committee for Aeronautics: NACA TN321. p. 2–8.
- [2] Wagner, H., (1932), Landing of sea planes, NACA Tech Memo.
- [3] Dobrovolskaya, Z.N., 1969. On some problems of similarity flow of fluid with a free surface. Journal of Fluid Mechanics 36(4).
- [4] Payne, P.R., 1988. Design of high-speed boats, vol. 1: Planing. Fishergate Inc.
- [5] Korobkin, A.A., Pokhnachov, V.V., 1988. Initial stage of water impact. Annual Review of Fluid Mechanics 20.
- [6] Zhao R, Faltinsen OM (1993) Water entry of two-dimensional bodies. J Fluid Mech 246:593–612
- [7] Mei, X., Lui, Y., Yue, D.K.P., 1999. On the water impact of general two-dimensional sections. Applied Ocean Research 21.
- [8] Zamanirad S., Seif M. S., (2013) Hydroelastic analysis of water impact on wedge-shaped sections, Proceeding of NAVA 2013 Conference, p. 192-199.
- [9] Bisplinghoff, R.L. and Doherty, C.S., (1952), Some studies of the impact of vee wedges on a water surface. Journal of the Franklin Institute. Vol. 253(6): p. 547-561.
- [10] Chuang, S.L., 1970. “Investigation of Impact of Rigid and Elastic Bodies with Water,” Management Information Services.
- [11] Chuang, S.-L., 1967. Experiments on slamming of wedge-shaped bodies. Journal of Ship Research.

- [12] Ochi, M.D., Bonilla-Norat, J., 1970. Pressure-velocity relationship in impact of a ship model dropped onto the water surface and in slamming in waves. Naval Ship Research and Development Center Washington DC, US Department of Commerce, National Technical Information Service.
- [13] Chuang, S.-L., 1973. Slamming tests of three-dimensional models in calm water and waves. Naval Ship Research and Development Center Bethesda, MD, US Department of Commerce, National Technical Information Service.
- [14] Greenhow, M. and Lin, W.-M., Nonlinear free surface effects. Theory and experiment.
- [15] Lin, M.C. and Ho, T.Y., (1994), Waterentry for a wedge in arbitrary water depth. *Engineering Analysis with Boundary Elements*. Vol. 14(2): p. 179-185.
- [16] Zhao, R., Faltinsen. O.M., and Aarsnes, J., “Water Entry of Arbitrary Two dimensional Sections with and without Flow Separation,” 21st Symposium on Naval Hydrodynamics. 1997. Trondheim, Norway: The National Academies Press.
- [17] Lin, M.-C., Shieh, L.-D., 1997. Simultaneous measurements of water impact on a two-dimensional body. *Fluid Dynamics Research* 19, 125–148.
- [18] Engle, A., Lewis, R., 2003. A comparison of hydrodynamic impacts prediction methods with two dimensional drop test data. *Marine Structures* 16, 175–182.
- [19] Faltinsen, O.M., Landrini, M., Greco, M., 2004. Slamming in marine applications. *Journal of Engineering Mathematics* 48, 187 –217.
- [20] Wu, G.X., Sun, H. and He, Y.S., (2004), Numerical simulation and experimental study of water entry of a wedge in free fall motion. *Journal of Fluids and Structures*. Vol. 19(3): p. 277-289.
- [21] Yettou, E.-M., Desrochers, A. and Champoux, Y., (2006), Experimental study on the water impact of a symmetrical wedge. *Fluid Dynamics Research*. Vol. 38(1): p. 47-66.
- [22] Sayeed, T.M., Peng, H. and Veitch, B., (2010), Experimental investigation of slamming loads on a wedge, in *The International Conference on Marine Technology: Dhaka, Bangladesh*.
- [23] Javaherian, M.J., Zeraatgar, H. and Hassani Chalaksara. E., (2012), Experimental investigation of asymmetric entry of a wedge shaped body, *International Conference on Violent Flows: Nantes, France*.